

# OCM PRODUCTS GENERAL CATALOG



**ORIENTAL CHAIN MFG.CO.,LTD.**

485 Miyanagaichi-machi, Hakusan-shi, Ishikawa-ken, Japan.

Phone : +81-76-276-1156 Fax : +81-76-274-9030

E-mail : ocm@ocm.co.jp

<http://www.ocm.co.jp/english.html>

*ISO 9001*  
Cert JQA 1248



JAPAN QUALITY ASSURANCE ORGANIZATION



THE INTERNATIONAL CERTIFICATION NETWORK



OCM chains are used in various equipment. The company was founded in 1947 to manufacture chains. Since then OCM has been engaged in the manufacture of roller chains, conveyors and sprockets. OCM is, therefore, in a position to meet customer's requirements with broad experience and endless research.

For over 58 years OCM's effort has been to solve the problems of industry. OCM S10 the world's smallest chain and OSB Series OCM has first manufactured indicate its ability.

OCM's dedication is to provide products that help solve the problems of industry in the world.

# *ISO 9001*

## *Cert JQA 1248*



# I N D E X

Warning	4
Cutting and Connecting of Chain	80
OCM Roller Chain Dimensions	5
Features of OCM Roller Chain	6
Construction of Roller Chain	7
Chain Drive Selection	8 - 13
Lubrication	14



## Roller Chain

OSB Series Roller Chain ANSI 40 to 240	15 - 16
ANSI Roller Chain 25 to 240	17 - 30
ANSI Heavy Series 35H to 200H	31
Double Pitch Roller Chain 2040 to 2080	32



## Self Lubricating Chain

Self Lubricating Chain	33
Self Lube ANSI 35 to 120 and C2040 to C2082H	34 - 35
Self Lube Attachment 35 to 80 and C2040 to C2082H	36 - 37



## Extra Heavy Duty Chain

Extra Heavy Duty Chain	38
Extra Heavy Duty HS Series HS80 to HS240	39
Extra Heavy Duty HSG Series HSG 80 to HSG 200	40
Extra Heavy Duty Special H Series	41

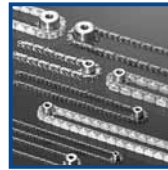

## Mini Pitch Chain

Mini Pitch Chain S10, 15 and 25H	42 - 44
----------------------------------	---------



## BS / DIN Roller Chain

BS / DIN Roller Chain 04 to 32B	45
BS / DIN Stainless and Nickel Plated Chain	46
BS / DIN Self Lubricating Chain	47



## Corrosion and Heat Resistance Chain

Corrosion and Heat Resistance Chain	48
ANSI Stainless Roller Chain 15 to 120	49
Stainless Double Pitch Roller Chain C2040 to C2082H	50
Stainless Hollow Pin Chain 40HP to 80HP C2040HP to C2082HP	51
Super Shield Roller Chain	52
Nickel Plated Roller Chain and Low Temperature Chain	53



## Engineering Plastic Chain LEAF Chain

Engineering Plastic Chain	54
Plastic Chain Plamate and Attachment	55
Placurve Chain	56
Straight Running Plastic Chain	57
Plalink Chain	58
Clip Top Chain	59
Double Pitch Plalink and Double Pitch Chain with Plastic Roller	60
Leaf Chain BL and AL Series	61 - 62

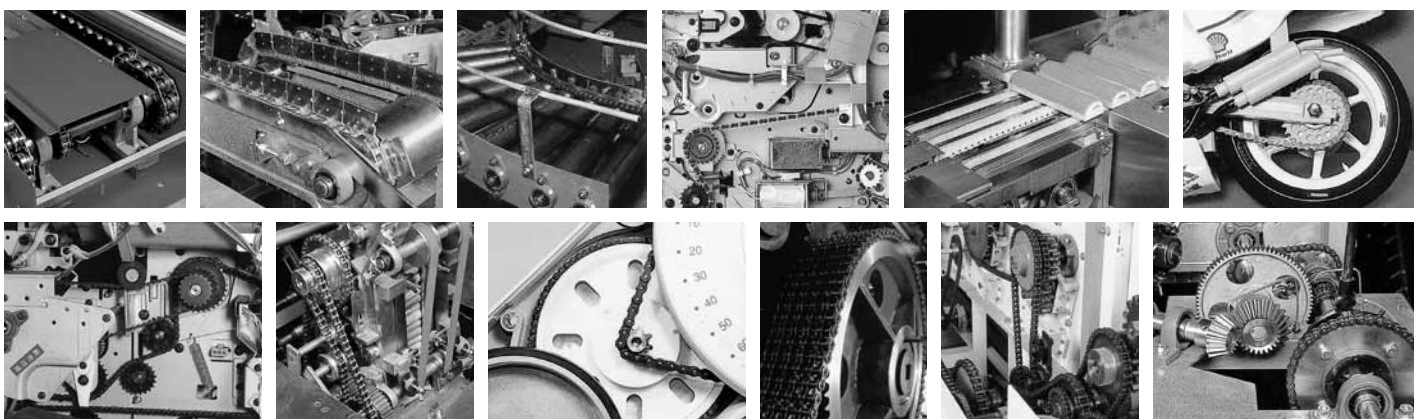



## Small Conveyor Chain

Circular Chain (Curved Chain)	63
Double Pitch Conveyor Chain C2040 to C2160H C2042 to C2162H	64
ANSI Roller Chain with Attachment 25 to 160	65
Double Pitch Roller Chain with Attachment	66
ANSI Roller Chain with Extend Pin 35 to 120	67
Double Pitch Roller Chain with Extend Pin C2040 to C2102H	68
ANSI Roller Chain with Wide Contour Attachment	69
Double Pitch Roller Chain with Threaded Hole Attachment	70
ANSI Straight Link Plate Chain and Deep Link Chain	71
Top Roller Chain	72
Roller Chain with Outboard Roller	73
Wide Chain with Cross Rods	74
Hollow Pin Chain	75
Indented Attachments	76
Bai Speed Chain	77
Custom Attachment Chain	78 - 79



## Conveyor Chain

Construction of Conveyor Chain	81
Dimensions of FM,FMH,FE and FEH Standard Conveyor Chain	82 - 83
Attachment A-2,K-2,SA-2 and SK-2	84
Attachment G-2 and G-4	85
Flow Conveyor	86 - 87
Deep Link Conveyor and Outboard Conveyor Chain	88
Apron Conveyor Chain	89
Apron Conveyor and Curve (Sidebow) Conveyor Chain	90

**Roller Chain**

**Self Lubricating Chain**

**Extra Heavy Duty Chain**

**Mini Pitch Chain**

**BS / DIN Roller Chain**

**Corrosion and Heat Resistance Chain**

**Engineering Plastic Chain**

**LEAF Chain**

**Small Conveyor Chain**

**Conveyor Chain**



# WARNING

## 1. Attention

All the OCM products are carefully manufactured. However, improper selection, handling or maintenance may result in a serious accident. Please refer to OCM product catalogs and related instructions. If you have any questions, please contact us.

## 2. Warning for handling chains and sprockets

When connecting or disconnecting chain,

- a) Wear safety glasses, gloves, safety shoes and protective clothing suitable for the job.
- b) Support the chain to prevent the uncontrolled movement of chain and parts.
- c) Use proper tools in good condition suitable for connecting and disconnecting chain.
- d) Don't insert or remove pins without knowing their correct direction.
- e) Not only a person being at work but also a person nearby should follow the above instructions.

## 3. Lock out power switch

When installing, dismantling or maintenance servicing like lubricating chain, always lock out power switch to avoid an accident.

## 4. Prevent secondary accident

Always clear around the working area in order to prevent secondary accident.

## 5. To replace parts of chain is dangerous

When replacing worn chain or sprocket, do not attempt to rebuild chains by using parts of disassembled chains. Replace all of them with new ones.

## 6. Reprocessing chain is dangerous

Do not try to reprocess chain. Almost all parts of chain are hardened by heat treatment.

- 1) Plating or some surface treatment of heat treated parts may result in the destruction of chain.
- 2) Do not weld heat treated chain, sprockets and their parts. It may lead to crack them and decrease their strength by heat influence.
- 3) Do not anneal heat treated chain, sprockets and their parts.

## 7. Remove any object interfering with chain and sprocket

Any object interfering with driving chain and sprocket is not only dangerous but make their life span short. Always check and remove the interfering object.

## 8. Lubrication

Constant lubrication prolongs the life of almost all chain. If the chain that need lubrication has been kept long time unlubricated, the life of chain is shorter than expected.

## 9. Washing

When washing chain, don't use any acid, alkali, gasoline and high vaporized solvent. Dip it into kerosine and after that, lubricate it well.

## 10. Aligning shaft and sprockets

To operate the chain normally, sprockets must make a straight line and shafts must be installed and aligned horizontally.

## 11. Build and install chain

- 1) Refer to the item above #1 to 10.
- 2) Connecting link
  - A. Connecting plate
    - a) Loose fit type : It is easy to set the connecting plate into pins.
    - b) Semi-press fit type : Drive connecting plate into pins by hammer.
  - B. Spring clip
    - a) Insert well in right direction.
  - C. Cottered pin
    - a) Do not use the cotter pins on the market. Use only the supplied cotters.
    - b) Install as shown below.

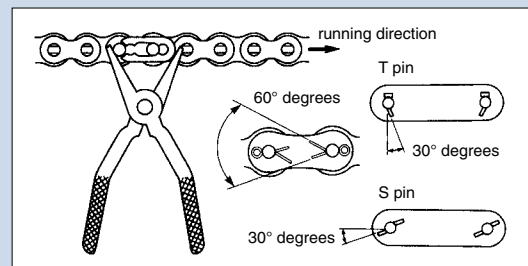

- 3) Do not alter link hole and pin diameter to make them easier fit into chain.
- 4) Do not use any used parts, such as spring clip, cotter pin, connecting plate and so on.
- 5) Check before driving
  - A. Connecting link is connected well and properly.
  - B. Chain engages with teeth of sprockets.
  - C. There is no object interfering and scattering around device.
  - D. Safety cover has been installed.
  - E. There is no object interfering with the chain or the safety cover.
  - F. There is nothing unusual on the connecting link.
  - G. There is no unusual noise.

## 12. Life span of chain and sprocket

Due to the difference of operating environment, condition, teeth of sprocket, status of lubricating and so on, the life span of chains is different even if the chains are the same type and same size. If new chain is used with old sprocket with worn teeth, or if new sprocket is used with old chain that has already been elongated, the life of chain and sprocket gets shorter.

# OCM ROLLER CHAIN

## ROLLER CHAIN DIMENSIONS

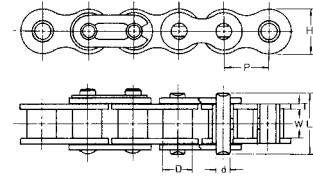

UNIT Upper:inch  
Beneath:mm

ANSI standard roller chain

OCM Chain No.	Pitch	Roller Diam.	Width between L.P.	Link Plate		Pin Diam.	Pin	Average Tensile Strength	Max. Working Load	Weight
	P	D	W	H	T	d	L	Lb/kgf	Lb/kgf	Lb/ft kg/m
25	0.25	0.13	0.126	0.23	0.03	0.091	0.307	1058	154	0.087
	6.350	3.300	3.200	5.850	0.750	2.300	7.800	480	70	0.13
35	0.375	0.2	0.189	0.354	0.049	0.141	0.461	2601	419	0.242
	9.525	5.080	4.800	9.000	1.250	3.580	11.700	1180	190	0.36
40	0.5	0.312	0.313	0.472	0.059	0.156	0.634	4299	860	0.443
	12.700	7.920	7.950	12.000	1.500	3.960	16.100	1950	390	0.66
41	0.5	0.306	0.252	0.382	0.049	0.141	0.524	2403	463	0.275
	12.700	7.770	6.400	9.700	1.250	3.580	13.300	1090	210	0.41
50	0.625	0.4	0.376	0.591	0.079	0.2	0.799	7165	1389	0.726
	15.875	10.160	9.550	15.000	2.000	5.080	20.300	3250	630	1.08
60	0.75	0.469	0.5	0.709	0.094	0.234	1	9921	2094	1.075
	19.050	11.910	12.700	18.000	2.400	5.950	25.400	4500	950	1.6
80	1	0.625	0.626	0.949	0.126	0.313	1.287	17637	3638	1.881
	25.400	15.880	15.900	24.100	3.200	7.940	32.700	8000	1650	2.8
100	1.25	0.75	0.754	1.185	0.157	0.375	1.571	26455	5512	2.822
	31.750	19.050	19.150	30.100	4.000	9.530	39.900	12000	2500	4.2
120	1.5	0.875	1.006	1.425	0.189	0.437	1.972	37038	7275	4.166
	38.100	22.230	25.550	36.200	4.800	11.110	50.100	16800	3300	6.2
140	1.75	1	1.004	1.661	0.22	0.5	2.134	48722	9700	5.174
	44.450	25.400	25.500	42.200	5.600	12.700	54.200	22100	4400	7.7
160	2	1.125	1.25	1.898	0.252	0.563	2.72	60186	12125	6.652
	50.800	28.580	31.750	48.200	6.400	14.290	69.100	27300	5500	9.9
180	2.25	1.406	1.406	2.134	0.283	0.687	3.138	73634	14110	9.044
	57.150	35.710	35.700	54.200	7.200	17.460	79.700	33400	6400	13.46
200	2.5	1.562	1.5	2.366	0.315	0.781	3.358	101413	15873	11.087
	63.500	39.680	38.100	60.100	8.000	19.840	85.300	46000	7200	16.5
240	3	1.875	1.89	2.85	0.374	0.937	4.122	149914	21826	16.664
	76.200	47.630	48.000	72.400	9.500	23.800	104.700	68000	9900	24.8

UNIT Upper:inch  
Beneath:mm

Mini Pitch Series

OCM Chain No.	Pitch	Roller Diam.	Width between L.P.	Link Plate		Pin Diam.	Pin	Average Tensile Strength	Max. Working Load	Weight
	P	D	W	H	T	d	L	Lb/kgf	Lb/kgf	Lb/ft kg/m
S10	0.125	0.067	0.051	0.114	0.016	0.045	0.144	220	44	0.02
	3.175	1.700	1.300	2.900	0.400	1.150	3.650	100	20	0.03
15	0.188	0.098	0.094	0.173	0.022	0.064	0.224	485	88	0.06
	4.763	2.480	2.380	4.400	0.570	1.620	5.700	220	40	0.09
25H	0.25	0.13	0.126	0.23	0.039	0.091	0.35	1146	209	0.108
	6.350	3.300	3.200	5.850	1.000	2.300	8.900	520	95	0.16

UNIT Upper:inch  
Beneath:mm

S Series

OCM Chain No.	Pitch	Roller Diam.	Width between L.P.	Link Plate		Pin Diam.	Pin	Average Tensile Strength	Max. Working Load	Weight
	P	D	W	H	T	d	L	Lb/kgf	Lb/kgf	Lb/ft kg/m
42	0.5	0.306	0.134	0.378	0.039	0.143	0.37	2205	300	0.215
	12.700	7.770	3.400	9.600	1.000	3.630	9.400	1000	136	0.32
43	0.5	0.306	0.189	0.378	0.039	0.143	0.425	2205	300	0.235
	12.700	7.770	4.800	9.600	1.000	3.630	10.800	1000	136	0.35
S43	0.5	0.306	0.189	0.472	0.059	0.156	0.512	4299	860	0.356
	12.700	7.770	4.800	12.000	1.500	3.960	13.000	1950	390	0.53
S44	0.5	0.306	0.252	0.472	0.059	0.156	0.575	4299	860	0.39
	12.700	7.770	6.400	12.000	1.500	3.960	14.600	1950	390	0.58
S52	0.625	0.4	0.252	0.591	0.079	0.2	0.673	7165	1389	0.638
	15.875	10.160	6.400	15.000	2.000	5.080	17.100	3250	630	0.95
S525	0.625	0.4	0.311	0.591	0.079	0.2	0.732	7165	1389	0.672
	15.875	10.160	7.900	15.000	2.000	5.080	18.600	3250	630	1.00
S63	0.75	0.469	0.376	0.709	0.094	0.234	0.882	9921	2094	0.941
	19.050	11.910	9.550	18.000	2.400	5.950	22.400	4500	950	1.40

# FEATURES OF OCM ROLLER CHAIN

## 1. Re-Punched Link Holes

OCM's repunching process removes the taper of hole. Both sides of the hole are parallel, better bearing between pins and holes. This process increases fatigue strength.

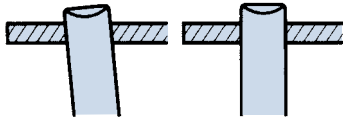

## 2. Shot-Peening

Rollers and link plates are shot peened to increase fatigue strength.

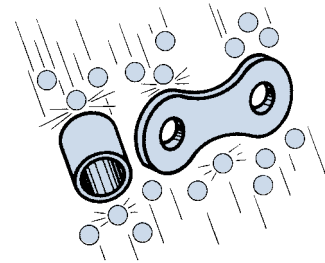

## 3. Oil Port oriented + Solid Bush

These holes, located on the inner side of the bushings away from bearing area, function as a reservoir for extra lubricant. This feature reduces chain wear and extend the chain's operating life.

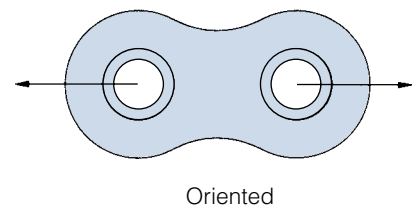

## 4. Cylindrical roundness of Solid Bush

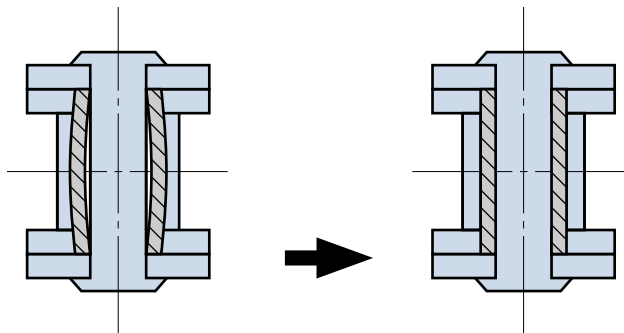

The advantage of solid bush, cylindrical roundness, making a large bearing area and oil port as an oil reservoir, improves the chain wear resistance and minimize an initial chain elongation.

## 5. Preloading

OCM roller chain is preloaded automatically after assembly to minimize initial elongation.

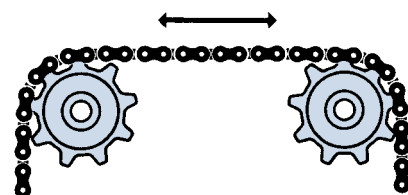

# ROLLER CHAIN

## CONSTRUCTION OF ROLLER CHAIN

Roller chain is made up of roller links and pin links.

Roller link consists of two bushings press-fitted into roller link plates with two free rotating rollers over the bushings. Pin link consists of two pin link plates into which two pins are press-fitted.

There are two types of pins. Rivet and cotter types.

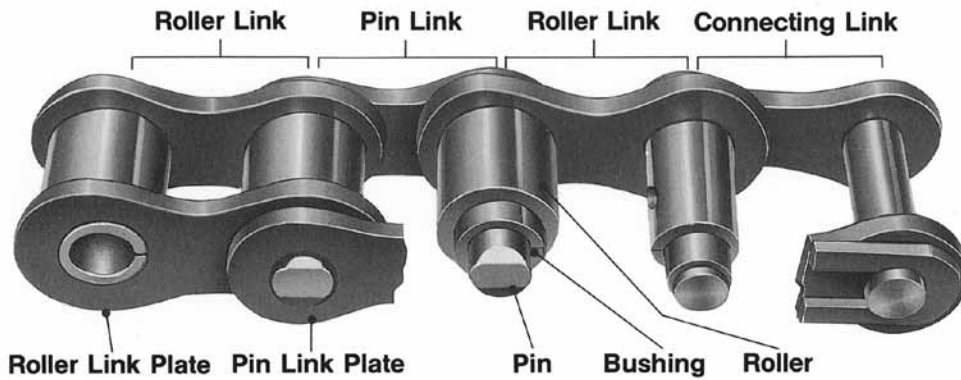

## ROLLER CHAIN CONNECTION

### CONNECTING LINKS

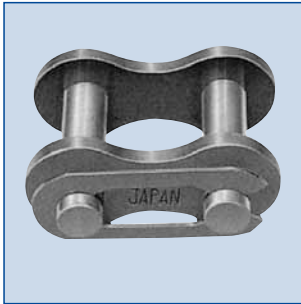

#### 1) Spring clip type

This is standard for all single and multiple strand ANSI standard chain, 80 and below and British standard chain, 16B and below.

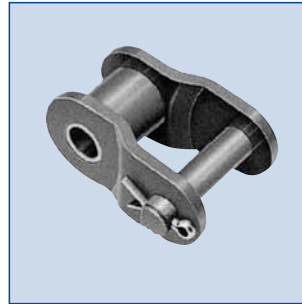

#### 3) Offset Link

An offset link is a combination of a roller link and a pin link. This link is used where the chain length is an odd number of pitches. It is recommended not to use an offset link whenever possible.



#### 2) Cotter type

This is standard for all single and multiple strand ANSI 100 and above, and British standard 20B and above.



#### 4) Two Pitch Offset Link

The unit consists of one offset and one roller link. Pins are press fitted into the link plates and the unit is more suitable for heavy impact load and high speed driving than one pitch offset link.



# EASY CHAIN SELECTION

Table 1 Easy selection chart

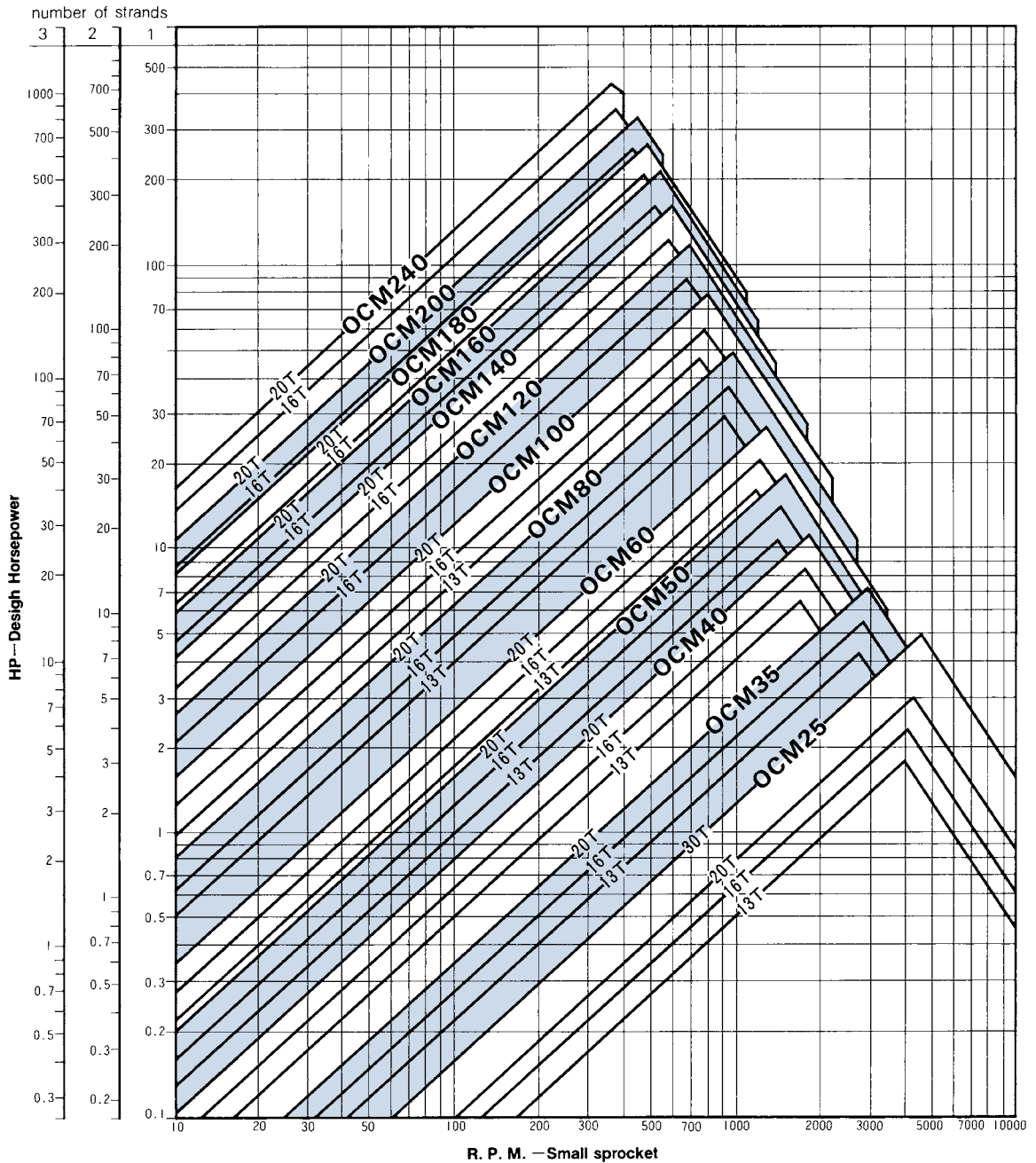

### How to Use Chart

1. The selection of OCM chain can be made by seeking the intersection of RPM of small sprocket (Horizontal line) and design horsepower (Vertical line).

Example:

The rpm of small sprocket is 200, and the design horsepower is 2HP. OCM 50 is obtained and the number of teeth in small sprocket is 13T to 16T.

Example:

The RPM of small sprocket is 600 with design horsepower of 8HP. In this case, OCM 50 and OCM 60 are sought. In case of OCM 50, the

number of teeth is 20T. In the event of OCM 60, the number of teeth is 13T.

After having made a tentative selection based on the chart, refer to the horsepower rating of the tentatively selected chain.

2. If the speed of chain is less than 50M/min., it is sometimes better to use a slow speed selection shown on page 10.

# DRIVE SELECTION PROCEDURE

Procedure for selecting roller chain for transmission

## GENERAL SELECTION

(1) The following information is required for chain selection:

1. Source of power
2. Power to be transmitted
3. Driven Equipment
4. Revolution of drive and driven shaft per minute, and the diameter of the shaft
5. Center distance of the shafts

(2) Determination of service factor

Select a service factor from Table 4 to compensate for the loads imposed on the chain by the type of input power and the type of equipment to be driven.

(3) Establish design horsepower

Multiply the power to be transmitted by the factor obtained from (2)

Single strand:

(A) Design horsepower =  $\frac{\text{The power to be transmitted} \times \text{service factor}}{\text{Multiple stand}}$

Multiple stand:

(B) Design horsepower =  $\frac{\text{The power to be transmitted} \times \text{service factor}}{\text{Multiple strand factor}}$

(4) Determination of number of teeth in small sprocket and roller chain

According to the number of revolutions and designing horsepower of a high speed shaft (in case of low speed, it is a drive shaft. In the event of overdrive, it is a driven shaft), refer to Table 1 Easy Selection Chart and horse power ratings and select an appropriate chain and the number of teeth of small sprocket. When you determine the number of teeth for small sprocket, check the bore capacity of the sprocket selected, making sure it will accommodate the driving shaft.

(5) Determination of number of teeth in the large sprocket

Multiply the drive ratio by the number of teeth in small sprocket.

### Selection Example (1)

Q1. A centrifugal compressor with 3HP is driven by an 1800 rpm electric motor. How to select chain and sprockets.

A1. Seek the service factor, 1.3, from Table 4.

Power to be transmitted  $\times$  Service factor = Design Horsepower  
 $3\text{HP} \times 1.3 = 3.9\text{HP}$

2. Refer to Table 1. Easy selection chart for 1800rpm 3.9HP, and OCM 35 chain with sprocket 16T to 20T is obtained.

3. Check horsepower ratings for chain 35, and as you see, the horsepower ratings of 35 17T with speed of 1800rpm is 3.93HP, which is

satisfactory.

4. The following are selected: Chain No 35  
Small sprocket 35 17T

### Selection Example (2)

Q1. The number of revolutions for drive is 500rpm and the power to be transmitted is 10HP. The rpm is reduced to 125 (1/4). The center distance should be 270mm with a space limitation of 480mm, and a uniform load. How to select chain and sprocket for this application.

A1. Design horsepower is computed as follows:

Design horsepower:  $10\text{HP} \times 1.0 = 10\text{HP}$

2. Select chain and the number of teeth for sprocket by referring to Table 1, Easy selection Chart and horsepower ratings.

OCM 60 18T has been selected.

3. Speed reduction ratio is  $0.25 = \frac{125\text{rpm}}{500\text{rpm}}$

Therefore, the number of teeth in the large

sprocket is  $72T = \frac{18T}{0.25}$

4. The outside diameter of the 18T is 119mm and the 72T is 447mm.

The space required for these arrangements is

$\frac{119+447}{2} + 270 = 553\text{mm}$  which can not be contained in the 480mm.

5. Multiple strand chain is selected.

OCM 50 - 2 16T to 20T is selected using Table 1, Easy Selection Chart. The design horsepower is obtained from the formula (B)

$$\frac{10\text{HP} \times 1.0}{1.7} = 5.88\text{HP}$$

(1.7 is multiple strand factor)

Refer to horsepower ratings. OCM 50 - 2, 18T is obtained. Its outside diameter is 99mm. The

large sprocket is  $72T = \frac{18T}{0.25}$  outside diameter

373mm. However, this selection can not be contained in the space.

6. Triple strand chain is selected in the same manner as above. OCM 50 - 3, 13T and 52T are obtained. The outside diameter of sprockets is 73mm, and 271 mm respectively.

$\frac{73+271}{2} + 270 = 442\text{mm}$  can be contained in the space required.

The chain and sprockets selected are OCM 50 - 3, 13T and 52T.

# SELECTION ON SPECIAL APPLICATIONS

If an application requires the speed of roller chain at less than 50m/min., it is necessary to take into account not wear elongation but fatigue strength. It is, therefore, economical to use a low speed selection method rather than the general selection procedure. For operations under special conditions, a different selection method is required from the general selection procedure.

## (1) Operation at low speeds

The formula below is used if the speed of chain is less than 50M/min. with infrequent starts and stops.

$$\text{Allowable load} \geq \text{Max load imposed on chain} \times \text{Service factor} \times \text{Speed factor}$$

Selection procedure is as follows:

1. Select slightly smaller roller chain and sprocket from a prime mover HP and RPM on Table 1 Easy Selection Chart.
2. Multiply the rpm of sprocket obtained by Table 2, the value of chain speed per one rpm of the sprocket to obtain the speed of chain, m/min.
3. To determine the max load imposed on chain.
4. Service factor from Table 4.
5. Speed factor is obtained from Table 3, speed factor.
6. Using the formula above, calculate the value obtained, and compare the allowable load of a roller chain tentatively selected on the item I above.

If not satisfactory to meet the requirements, please change the chain and sprocket and review.

### Note:

When operation conditions are frequent starts and stops and reversals of drive rotation, increase the service factors to compensate for the conditions or consult OCM.

## (2) Operations under abnormal atmosphere conditions

If the atmosphere condition of operation is worse than ordinary, consult OCM. If operation atmosphere is high temperature or corrosive, it is recommended to use stainless steel roller chain.

**Table 3 Speed Factor**

Speed of Roller chain (m/min)	Speed Factor	Remarks
<b>Less than 10</b>	1.0	
<b>10 and Less than 20</b>	1.1	
<b>20 and Less than 30</b>	1.2	
<b>30 and Less than 40</b>	1.3	
<b>40 and Less than 50</b>	1.4	
<b>50 and Less than 70</b>	1.6	Applicable only to OCM Stainless Roller Chain

**Table 2 Chain Speed per one rpm of Sprocket**

OCM ChainNo.	Number of teeth in sprocket																				
	10	11	12	13	14	15	16	17	18	19	20	21	22	23	24	25	26	27	28	29	30
<b>OCMS10</b>	0.032	0.035	0.038	0.041	0.044	0.048	0.051	0.054	0.057	0.060	0.064	0.067	0.070	0.073	0.076	0.079	0.083	0.086	0.089	0.092	0.095
<b>OCM 15</b>	0.048	0.052	0.057	0.062	0.067	0.071	0.076	0.081	0.086	0.090	0.095	0.100	0.105	0.110	0.114	0.119	0.124	0.129	0.133	0.138	0.143
<b>OCM 25</b>	0.064	0.070	0.076	0.083	0.089	0.095	0.102	0.108	0.114	0.121	0.127	0.133	0.140	0.146	0.152	0.159	0.165	0.171	0.178	0.184	0.191
<b>OCM 35</b>	0.095	0.105	0.114	0.124	0.133	0.143	0.152	0.162	0.171	0.181	0.191	0.200	0.210	0.219	0.229	0.238	0.248	0.257	0.267	0.276	0.286
<b>OCM 40</b>	0.127	0.140	0.152	0.165	0.178	0.191	0.203	0.216	0.229	0.241	0.254	0.267	0.279	0.292	0.305	0.318	0.330	0.343	0.356	0.368	0.381
<b>OCM 50</b>	0.159	0.175	0.191	0.206	0.222	0.238	0.254	0.270	0.286	0.302	0.318	0.333	0.349	0.365	0.381	0.397	0.413	0.429	0.445	0.460	0.476
<b>OCM 60</b>	0.191	0.210	0.229	0.248	0.267	0.286	0.305	0.324	0.343	0.362	0.381	0.400	0.419	0.438	0.457	0.476	0.495	0.514	0.533	0.552	0.572
<b>OCM 80</b>	0.254	0.279	0.305	0.330	0.356	0.381	0.406	0.432	0.457	0.483	0.508	0.533	0.559	0.584	0.610	0.635	0.660	0.686	0.711	0.737	0.762
<b>OCM100</b>	0.318	0.349	0.381	0.413	0.445	0.476	0.508	0.540	0.572	0.603	0.635	0.667	0.669	0.730	0.762	0.794	0.826	0.857	0.889	0.921	0.953
<b>OCM120</b>	0.381	0.419	0.457	0.495	0.533	0.572	0.610	0.648	0.686	0.724	0.762	0.800	0.838	0.876	0.914	0.953	0.991	1.029	1.067	1.105	1.143
<b>OCM140</b>	0.445	0.489	0.533	0.578	0.622	0.667	0.711	0.756	0.800	0.845	0.889	0.933	0.978	1.022	1.067	1.111	1.156	1.200	1.245	1.289	1.334
<b>OCM160</b>	0.508	0.559	0.610	0.660	0.711	0.762	0.813	0.864	0.914	0.965	1.016	1.067	1.118	1.168	1.219	1.270	1.321	1.372	1.422	1.473	1.524
<b>OCM200</b>	0.635	0.699	0.762	0.826	0.889	0.953	1.016	1.080	1.143	1.207	1.270	1.334	1.397	1.461	1.524	1.588	1.651	1.715	1.778	1.842	1.905
<b>OCM240</b>	0.762	0.838	0.914	0.991	1.067	1.143	1.219	1.295	1.372	1.448	1.524	1.600	1.676	1.753	1.829	1.905	1.981	2.057	2.134	2.210	2.286

# HORSEPOWER RATINGS TABLE

Horsepower ratings tables on the catalog are based on the following :

- (1) Under normal atmosphere conditions
- (2) Power transmission by single strand chain
- (3) Service factor of Table 4 is 1.0
- (4) Lubrication is appropriate.
- (5) Two shafts to transmit power is horizontal, properly located and installed.
- (6) Load variation is small.

To compensate for the loads imposed on the chain by the type of input power and the type of equipment to be driven, the selection of an appropriate service factor is required.

For multiple strand chains, apply a factor of multiple strand factor Table 5.

**Table 4 Service Factor**

Basis for service factor	Driven equipment	Service Factor		
		Electric motor or turbine	Internal combustion Engine with hydraulic drive	Internal combustion Engine without hydraulic drive
Uniform load	Agitators, liquid stock centrifugal blowers, generators, centrifugal pumps, conveyor or elevator uniformly loaded, machinery uniform load and non-reversing.	1.0	1.0	1.2
Mild (Moderate) shock load	Centrifugal compressor, kilns and dryers, conveyor and elevator with mild shock load, machinery with moderate pulsating.	1.3	1.2	1.4
Heavy shock load	Reciprocating compressor, crushers, reciprocating feeder, machinery with severe load or reversing.	1.5	1.4	1.7

Note: 1. Appropriate lubricant and lubrication should be used. See page 15. The surrounding temperature of -10°C to 60°C is considered normal.  
 2. When the surrounding temperature is less than -40°C, use refrigerating machine oil and multiply the service factor above by 2.0.

**Table 5 Multiple Strand Factors**

Number of strands	Multiple strand factors
2	1.7
3	2.5
4	3.3
5	3.9
6	4.6

### Chain Pitch

Use the smallest pitch chain that will meet requirements. If single strand chains can not satisfy requirements, use small pitch multiple strand chains. If the center distance should be short and the outside diameter of sprockets be small because of space restrictions, use multiple strand chains and sprockets with large number of teeth.

### Number of Teeth for Small Sprockets

The recommended number of teeth for small sprockets is not less than 17 for a quieter drive with less impact.

However, a sprocket with number of around 11 teeth can be used at a slow speed while at a high speed, the recommended number of teeth is not less than 25.

### Hardened Teeth

It is advisable to harden sprockets under the following operating conditions:

- SLOW SPEED AND HEAVILY LOADED DRIVES
- HIGH SPEED DRIVES
- LARGE RATIO DRIVES
- ABRASIVE OR CORROSIVE CONDITIONS

OCM ANSI 35 to 100 B type sprockets are induction hardened.

### Teeth of Large Sprockets

As the joint-wear of a roller chain progresses, it tends to jump or ride over the teeth of a sprocket. Chain life based on the joint-wear varies according to the number of teeth in large sprockets as shown in chart below.

Generally, the wear life of a roller chain is when the elongation per pitch is in the range of 2 - 3%. In this case, the number of teeth in large sprockets is 40 through 60.

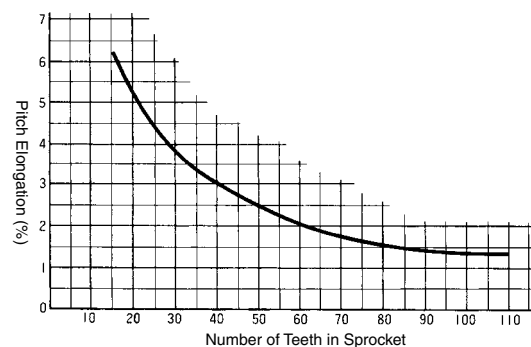

### Minimum Chain Wrap and Drive Ratio

The suggested minimum chain wrap on the small sprocket is not less than 120° to obtain smooth transmission (satisfactory operation). It is recommended therefore that the speed ratio for a single reduction drive be held not to exceed 1:7. If a large speed ratio is required, double reduction drive should be used.

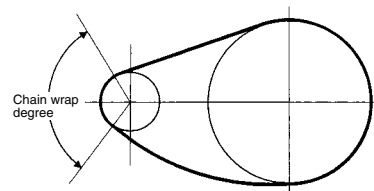

**Sprocket Bore Diameter**

Make sure the bore capacity of the sprocket selected will accommodate the shaft. If the sprocket selected does not accommodate the shaft, select a different number of teeth. If you can not change the number of teeth in the sprocket, review the shaft dia. and max. bore. The max bore is obtained using the formula.

$$\text{Max. bore} = P \left( \cot \frac{180}{N} - 1 \right) - 0.76$$

P = Chain pitch N = Number of teeth

**Variation in Chain Speed due to Chordal Action**

A roller chain that engages a sprocket forms a polygon. The ( position ) chain rises and falls, and a variation in chain speed occurs. The greater the number of teeth, the less will be the speed variation. The speed variation is reduced as the number of teeth on a small sprocket increases. A less speed variation is obtained as the number of teeth exceeds 25 as shown below.

**Service Factor**

For normal transmission, service factor Table 4 is used. However, under the following operating conditions, increase the service factors for better transmission.

- Frequent starts and stops
- Insufficient lubrication
- Shaft center distance is short
- A drive arrangement is vertical with a small sprocket located below
- Driven sprockets are more than two
- Reversing
- Load periodically varies

**Number of Links of Chain and Connecting Link**

We recommend that you use a chain length with an even number of pitches in order not to use an offset link. For low speed as shown in page 11 on low speed chain selection, we suggest chain endless is used without the use of a connecting or offset link. The fatigue strength (allowable load) of a connecting link and an offset link is lower than that of plain chain.

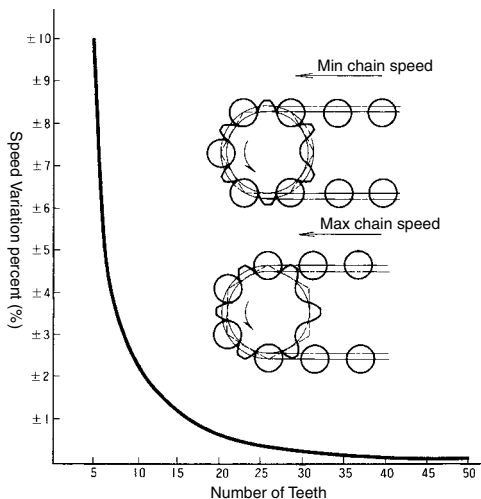

**Length of Chain**

If the type of chain and sprockets are determined on the basis of the selection method of roller chain drives and the shaft center distance is decided, the required length of chain is computed using the following formula and Table K factors.

$$L = \frac{N+n}{2} + 2C + \frac{K}{C}$$

L = CHAIN LENGTH, PITCHES  
 N = NUMBER OF TEETH IN LARGE SPROCKET  
 n = NUMBER OF TEETH IN SMALL SPROCKET  
 C = SHAFT CENTER, PITCHES  
 K = DETERMINE THE VALUE N-n, AND OBTAIN K FROM TABLE 6 K FACTORS

The number of pitches is obtained by omitting fractions. When L is an odd number, an offset link is required. We recommend that you avoid using an offset link. When possible, an even number of pitches by changing the shaft center distance or number of teeth on the sprocket is used.

**Shaft Center Distance**

If the length of chain and the number of teeth in the sprockets have already been determined, the shaft center distance is calculated using the following formula:

$$C = \frac{1}{8} \left\{ 2L - N - n + \sqrt{(2L - N - n)^2 - 0.811(N - n)^2} \right\}$$

C is Number of pitches

**Chain Speed and Load on Chain**

1. Chain speed is easily obtained from Table 2 chain speed per one rpm of sprocket.

The number of teeth on sprockets other than those on the Table 2 is obtained using the following formula:

$$V = \frac{P \cdot N \cdot n}{1,000} \text{ (m/min.)}$$

V = CHAIN SPEED ( M/MIN)  
 P = CHAIN PITCH ( MM)  
 N = NUMBER OF TEETH IN SPROCKET  
 n = RPM OF SPROCKET

2. Load on chain is found by the following formula:

$$F = \frac{4.567HP}{V} \text{ (kg)}$$

F = Load on chain (kg)  
 V = Chain speed (m/min.)

Note : In case of starts and braking of an electric motor, inertia takes place, and a larger load than the normal output horsepower of the motor may impose on chain.

Table 6 Factors K

N-n	K	N-n	K	N-n	K	N-n	K	N-n	K	N-n	K	N-n	K	N-n	K	N-n	K	N-n	K
1	0.03	20	10.13	39	38.53	58	85.21	77	150.18	96	233.44	115	334.99	134	454.83	153	592.96	172	749.37
2	0.10	21	11.17	40	40.53	59	88.17	78	154.11	97	238.33	116	340.84	135	461.64	154	600.73	173	758.11
3	0.23	22	12.26	41	42.58	60	91.19	79	158.09	98	243.27	117	346.75	136	468.51	155	608.56	174	766.90
4	0.41	23	13.40	42	44.68	61	94.25	80	162.11	99	248.26	118	352.70	137	475.42	156	616.44	175	775.74
5	0.63	24	14.59	43	46.84	62	97.37	81	166.19	100	253.30	119	358.70	138	482.39	157	624.37	176	784.63
6	0.91	25	15.83	44	49.04	63	100.54	82	170.32	101	258.39	120	364.76	139	489.41	158	632.35	177	793.57
7	1.24	26	17.12	45	51.29	64	103.75	83	174.50	102	263.54	121	370.86	140	496.47	159	640.38	178	802.57
8	1.62	27	18.47	46	53.60	65	107.02	84	178.73	103	268.73	122	377.02	141	503.59	160	648.46	179	811.61
9	2.05	28	19.86	47	55.95	66	110.34	85	183.01	104	273.97	123	383.22	142	510.76	161	656.59	180	820.70
10	2.53	29	21.30	48	58.36	67	113.71	86	187.34	105	279.27	124	389.48	143	517.98	162	664.77	181	829.85
11	3.06	30	22.80	49	60.82	68	117.13	87	191.73	106	284.67	125	395.79	144	525.25	163	673.00	182	839.04
12	3.65	31	24.34	50	63.33	69	120.60	88	196.16	107	290.01	126	402.14	145	532.57	164	681.28	183	848.29
13	4.28	32	25.94	51	65.88	70	124.12	89	200.64	108	295.45	127	408.55	146	539.94	165	689.62	184	857.58
14	4.96	33	27.58	52	68.49	71	127.69	90	205.18	109	300.95	128	415.01	147	547.36	166	698.00	185	866.93
15	5.70	34	29.28	53	71.15	72	131.31	91	209.76	110	306.50	129	421.52	148	554.83	167	706.44		
16	6.48	35	31.03	54	73.86	73	134.99	92	214.40	111	312.09	130	428.08	149	562.36	168	714.92		
17	7.32	36	32.83	55	76.62	74	138.71	93	219.08	112	317.74	131	434.69	150	569.93	169	723.46		
18	8.21	37	34.68	56	79.44	75	142.48	94	223.82	113	323.44	132	441.36	151	577.56	170	732.05		
19	9.14	38	36.58	57	82.30	76	146.31	95	228.61	114	329.19	133	448.07	152	585.23	171	740.68		

**Installation and Arrangement**

The arrangements A, B and C are preferred, and will operate satisfactorily in either direction. If the least recommended arrangements are necessary due to application realities, chain tensioners or some other means are required. In case a shaft center distance is short, the frequency of chain rotations increases and the chain is inclined to elongate faster. In general, a preferred center distance is 30 to 50 times chain pitches. A minimum center distance should be sufficient to give clearance between the teeth of the two sprockets. The minimum center distance should be not less than the diameter of the large sprocket plus one half the diameter of the small sprocket.

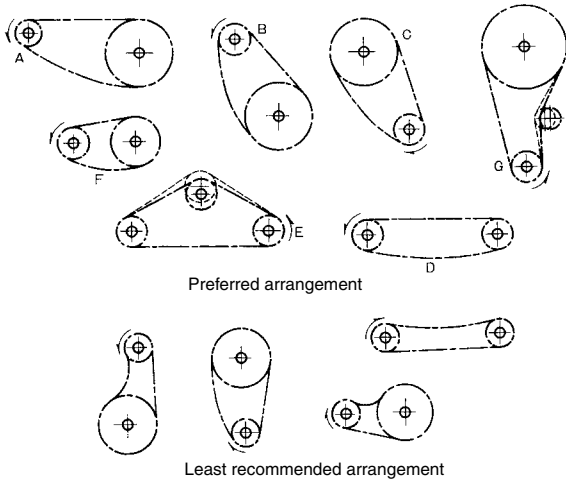

**Prevention of Chain Vibration**

If a vibration takes place due to transmission conditions, please install a guide.

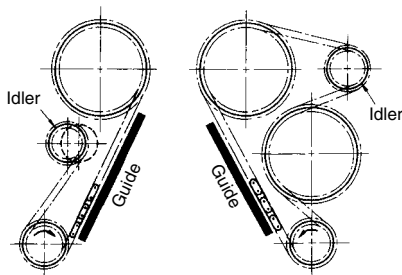

**Chain Sag**

The amount of chain sag (SS') is generally 4% of the span. The sag should be 2% of the span for the following applications:

- (1) Drive arrangements are vertical or similar.
- (2) Heavy load and frequent starts.
- (3) Shaft center distance is more than one meter.
- (4) Travel direction of chain is often reversed.

In case chain elongates, the center distance is adjusted by moving one shaft. It is convenient, therefore, that one shaft is made movable from the center distance by two percent.

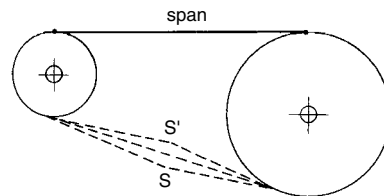

**Aligning Shafts and Sprockets**

The distance D of two shafts should be the same and the two shafts should be aligned horizontally. Apply a straight edge to the sprocket surfaces to see if two sprockets are in the same plane.

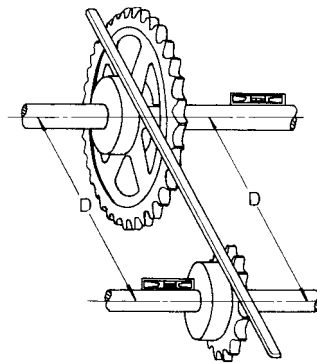

## LUBRICATION

The long service life of chain depends highly on lubrication. An optimum lubrication is an important factor in obtaining a desired life of chain. Please use the lubrication types as shown in the Horsepower ratings table.

### Application of lubricant to chains

Apply oil as shown so that oil will arrive at bearing surfaces of chain and an oil film will be maintained among the pin, bushing and roller. The amount of wear is reduced and the life of chain is prolonged.

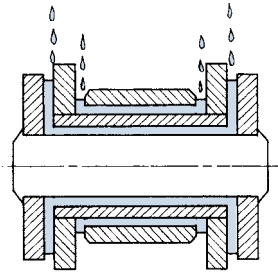

### Selection of the lubricant

Use only high quality oil. The lubricants suggested for specific temperature ranges are shown in the following selection table.

### Selection Table (Viscosity)

SURROUNDING TEMPERATURE C		SAE VISCOSITY NUMBER
-10°C	THRU 0°C	SAE 20
0°C	THRU 40°C	30
40°C	THRU 50°C	40
50°C	THRU 60°C	50

Note:

- (1) For manual lubrication, if oil drips from chain, use a high viscosity lubricant.
- (2) If the surrounding temperature is less than -10°C it is recommended to use refrigerating machine oil.
- (3) If the surrounding temperature is not less than 60, please consult us.

### Type of Lubrication

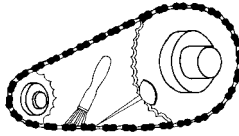
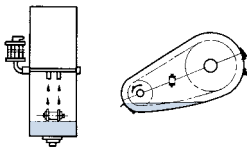
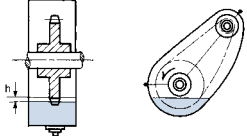
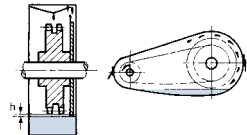
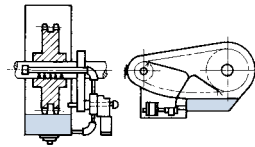
I		<p><b>Manual lubrication</b></p> <p>Oil is applied with a brush or oil can. Every 4 to 8 hours, the oil should be applied to between link plates in the lower span of the chain.</p>
		<p><b>Drip feed lubrication</b></p> <p>A simple casing is required. About twenty drops of oil per minute are distributed from a drip lubricator between the link plates.</p>
II		<p><b>Oil bath lubrication</b></p> <p>A leak-proof casing is required. The chain dips into an oil reservoir. The sprockets should dip into the oil one half inch. If the sprocket dips too deep, heat is generated.</p>
		<p><b>Disc lubrication</b></p> <p>A leak proof casing is required. The chain operates above the oil level. The disc should dip into the oil one half to one inch.</p>
III		<p><b>Pump lubrication</b></p> <p>A leak proof casing is required. The oil is circulated with a pump and the oil should be cooled.</p>

Chain drives should be inspected at intervals to assure that the lubrication is functioning properly. If the chain and bushing is discolored, grooved or galled, the chain will not be sufficiently lubricated. For better lubrication, inspect the chain after it is periodically removed and washed with kerosine.

# OCM ROLLER CHAIN

## OSB SERIES ROLLER CHAIN

OCM introduces, OSB Series, oil port oriented solid bush roller chain with solid roller. Over 30 years' experience of manufacturing oil port roller chain made this possible. It incorporates the advantage of solid bush, cylindrical roundness, making a large bearing area and oil port as oil reservoir. The large bearing area and oil port, acting as an oil reservoir, improve the wear resistance and prolong the chain life by 30% as compared with solid bush chain without oil port under no lubricating condition.

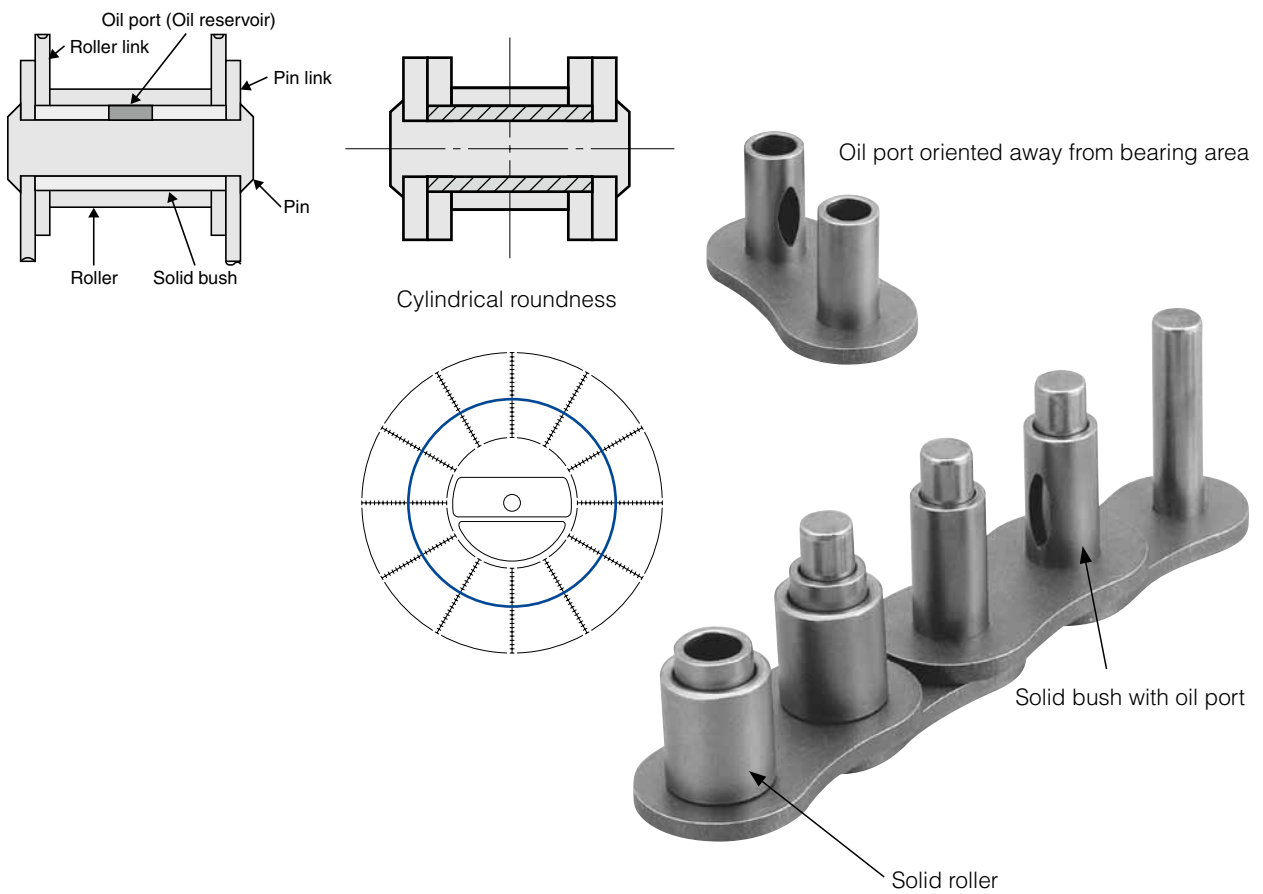

----- Split bush without oil port    ——— Solid bush without oil port    ——— Solid bush with oil port

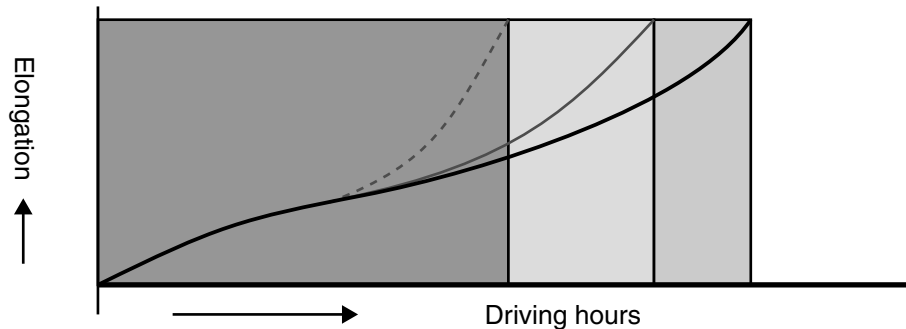

Data are based on OCM's test.



# OSB SERIES ROLLER CHAIN

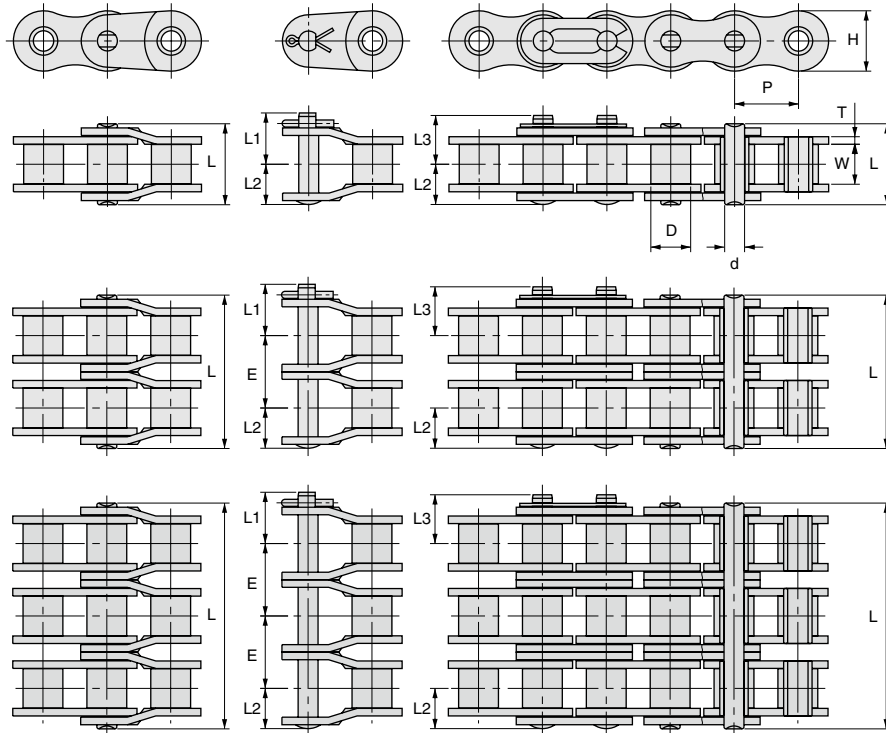

UNIT:inch

OCM Chain No.	Pitch	Roller Diam.	Width between L.P.	Link Plate		Pin Diam.	Pin				Trans Pitch	Average Tensile Strength	Max. Working Load	Approx Weight
	P	D	W	H	T	d	L	L1	L2	L3	E	Lbs	Lbs	Lbs/ft
OSB 40-1	0.500	0.312	0.313	0.472	0.059	0.156	0.634	0.402	0.319	0.382	0.567	4,290	860	0.44
OSB 40-2							1.201					8,590	1,450	0.87
OSB 40-3							1.772					12,880	2,130	1.30
OSB 50-1	0.625	0.400	0.376	0.591	0.079	0.200	0.799	0.476	0.409	0.476	0.713	7,160	1,380	0.73
OSB 50-2							1.512					14,330	2,350	1.43
OSB 50-3							2.228					21,400	3,460	2.14
OSB 60-1	0.750	0.469	0.500	0.709	0.094	0.234	1.000	0.598	0.500	0.579	0.898	9,920	2,090	1.08
OSB 60-2							1.898					19,840	3,540	2.08
OSB 60-3							2.799					29,760	5,220	3.09
OSB 80-1	1.000	0.625	0.626	0.949	0.126	0.313	1.287	0.776	0.709	0.740	1.154	17,630	3,630	1.88
OSB 80-2							2.445					35,270	6,180	3.76
OSB 80-3							3.598					52,900	9,090	5.58
OSB 100-1	1.250	0.750	0.754	1.185	0.157	0.375	1.571	0.925	0.846	0.787	1.409	26,450	5,510	2.82
OSB 100-2							2.980					52,900	9,370	5.64
OSB 100-3							4.394					79,360	13,770	8.40
OSB 120-1	1.500	0.875	1.006	1.425	0.189	0.437	1.972	1.118	1.071	0.988	1.787	37,030	7,270	4.17
OSB 120-2							3.764					74,070	12,360	8.20
OSB 120-3							5.551					111,110	18,180	12.30
OSB 140-1	1.750	1.000	1.004	1.661	0.220	0.500	2.134	1.252	1.150	1.067	1.925	48,720	9,700	5.17
OSB 140-2							4.063					97,440	16,490	10.15
OSB 140-3							5.988					146,160	24,250	15.19
OSB* 160-1	2.000	1.125	1.262	1.898	0.252	0.563	2.476	1.437	1.378	1.236	2.303	60,180	12,120	6.65
OSB* 160-2							4.780					120,370	20,610	13.17
OSB* 160-3							7.083					180,550	30,310	19.69
OSB* 200-1	2.500	1.562	1.512	2.374	0.315	0.781	3.063	1.811	1.681	1.531	2.819	101,410	15,870	11.09
OSB* 200-2							5.882					202,820	26,980	21.84
OSB* 200-3							8.701					304,230	39,680	32.66
OSB* 240-1	3.000	1.875	1.902	2.850	0.374	0.937	3.717	2.157	2.043	1.858	3.457	149,910	21,820	16.66
OSB* 240-2							7.173					299,820	37,100	32.93
OSB* 240-3							10.630					449,740	54,560	49.12

Connecting link for 40 through 60 is spring clip. Spring clip and cotter for 80 are available. Cotter type for 100 through 240.  
\*Indicates roller chain with solid bush but without oil port.

# OCM ANSI ROLLER CHAIN

Chain No. **25** Pitch • 0.250inch / 6.35mm

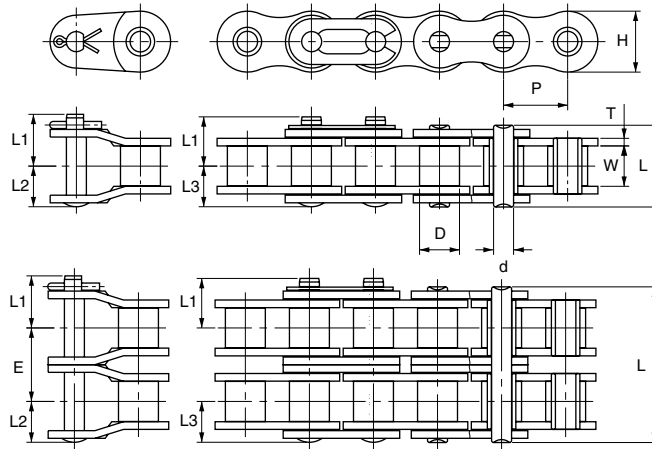

UNIT Upper:inch  
Beneath:mm

OCM Chain No.	ANSI No.	Pitch P	Roller Diam. D	Width between L.P. W	Link Plate		Pin Diam. d	Pin				Trans Pitch E	Average Tensile Strength Lb/kg	Max. Working Load Lb/kg	Approx Weight Lb/ft kg/m
					H	T		L	L1	L2	L3				
OCM25	25	0.250	0.130	0.126	0.230	0.030	0.091	0.307	0.189	0.162	0.154	0.252	1,058	154	0.087
		6.35	3.3	3.2	5.85	0.75	2.30	7.8	4.8	4.1	3.9	6.4	480	70	0.13
OCM25-2	25-2	0.250	0.130	0.126	0.230	0.030	0.091	0.563	0.189	0.162	0.154	0.252	2,117	243	0.180
		6.35	3.3	3.2	5.85	0.75	2.30	14.3	4.8	4.1	3.9	6.4	960	110	0.27

1. Chain is rollerless. Available only in rivetted construction.  
Note: Dimensions subject to change. Certified dimensions furnished upon request.

## HORSEPOWER RATINGS SINGLE STRAND ROLLER CHAIN

No. of Teeth Small Spkt.	REVOLUTIONS PER MINUTE-SMALL SPROCKET																								
	50	100	300	500	700	900	1200	1500	1800	2100	2500	3000	3500	4000	4500	5000	5500	6000	6500	7000	7500	8000	8500	9000	10000
11	0.03	0.05	0.14	0.23	0.31	0.39	0.50	0.62	0.73	0.83	0.98	1.15	1.32	1.38	1.16	0.99	0.86	0.75	0.67	0.60	0.54	0.49	0.45	0.41	0.35
12	0.03	0.06	0.16	0.25	0.34	0.43	0.55	0.68	0.80	0.92	1.07	1.26	1.45	1.57	1.32	1.12	0.97	0.86	0.76	0.68	0.61	0.56	0.51	0.47	0.40
13	0.04	0.06	0.17	0.27	0.37	0.47	0.60	0.74	0.87	1.00	1.17	1.38	1.58	1.77	1.49	1.27	1.10	0.96	0.86	0.77	0.69	0.63	0.57	0.53	0.45
14	0.04	0.07	0.19	0.30	0.40	0.50	0.65	0.80	0.94	1.08	1.27	1.49	1.71	1.93	1.66	1.42	1.23	1.08	0.96	0.86	0.77	0.70	0.64	0.59	0.50
15	0.04	0.07	0.20	0.32	0.43	0.54	0.70	0.86	1.01	1.17	1.36	1.61	1.85	2.08	1.84	1.57	1.36	1.20	1.06	0.95	0.86	0.78	0.71	0.65	0.56
16	0.04	0.08	0.22	0.34	0.47	0.58	0.76	0.92	1.09	1.25	1.46	1.72	1.98	2.23	2.03	1.73	1.50	1.32	1.17	1.05	0.94	0.86	0.78	0.72	0.61
17	0.05	0.08	0.23	0.37	0.50	0.62	0.81	0.99	1.16	1.33	1.56	1.84	2.11	2.38	2.22	1.90	1.64	1.44	1.28	1.14	1.03	0.94	0.86	0.79	0.67
18	0.05	0.09	0.25	0.39	0.53	0.66	0.86	1.05	1.24	1.42	1.66	1.96	2.25	2.53	2.42	2.07	1.79	1.57	1.39	1.25	1.12	1.02	0.93	0.86	0.73
19	0.05	0.09	0.26	0.41	0.56	0.70	0.91	1.11	1.31	1.50	1.76	2.07	2.38	2.69	2.62	2.24	1.94	1.70	1.51	1.35	1.22	1.11	1.01	0.93	0.79
20	0.06	0.10	0.28	0.44	0.59	0.74	0.96	1.17	1.38	1.59	1.86	2.19	2.52	2.84	2.83	2.42	2.10	1.84	1.63	1.46	1.32	1.20	1.09	1.00	0.86
21	0.06	0.11	0.29	0.46	0.62	0.78	1.01	1.24	1.46	1.68	1.96	2.31	2.66	2.99	3.05	2.60	2.26	1.98	1.76	1.57	1.42	1.29	1.17	1.08	0.92
22	0.06	0.11	0.31	0.48	0.66	0.82	1.07	1.30	1.53	1.76	2.06	2.43	2.79	3.15	3.27	2.79	2.42	2.12	1.88	1.69	1.52	1.38	1.26	1.16	0.99
23	0.06	0.12	0.32	0.51	0.69	0.86	1.12	1.37	1.61	1.85	2.16	2.55	2.93	3.30	3.50	2.98	2.59	2.27	2.01	1.80	1.62	1.47	1.35	1.24	1.06
24	0.07	0.13	0.34	0.53	0.72	0.90	1.17	1.43	1.69	1.94	2.27	2.67	3.07	3.46	3.73	3.18	2.76	2.42	2.15	1.92	1.73	1.57	1.44	1.32	1.12
25	0.07	0.13	0.35	0.56	0.75	0.94	1.22	1.50	1.76	2.02	2.37	2.79	3.21	3.61	3.96	3.38	2.93	2.57	2.28	2.04	1.84	1.67	1.53	1.40	1.20
26	0.07	0.14	0.37	0.58	0.79	0.98	1.28	1.56	1.84	2.11	2.47	2.91	3.34	3.77	4.19	3.59	3.11	2.73	2.42	2.17	1.95	1.77	1.62	1.49	1.27
28	0.08	0.15	0.40	0.63	0.85	1.07	1.38	1.69	1.99	2.29	2.68	3.15	3.62	4.09	4.54	4.01	3.47	3.05	2.70	2.42	2.18	1.98	1.81	1.66	1.42
30	0.08	0.16	0.43	0.68	0.92	1.15	1.49	0.82	2.15	2.46	2.88	3.40	3.90	4.40	4.89	4.45	3.85	3.38	3.00	2.68	2.42	2.20	2.01	1.84	1.57
32	0.09	0.17	0.46	0.73	0.98	1.23	1.60	1.95	2.30	2.64	3.09	3.64	4.18	4.72	5.25	4.90	4.25	3.73	3.30	2.96	2.67	2.42	2.21	2.03	1.73
35	0.10	0.19	0.51	0.80	1.08	1.36	1.76	2.15	2.53	2.91	3.41	4.01	4.61	5.20	5.78	5.60	4.86	4.26	3.78	3.38	3.05	2.77	2.53	2.32	1.98
40	0.12	0.22	0.58	0.92	1.25	1.57	2.03	2.48	2.93	3.36	3.93	4.64	5.32	6.00	6.68	6.85	5.93	5.21	4.62	4.13	3.73	3.38	3.09	2.83	2.42
Lubri-cation	I					II										III									

See page 14, for lubrication type.  
For horsepower ratings of multiple strand, multiply the horsepower above by multiple strand factor on page 11.  
Note: Dimensions subject to change. Certified dimensions furnished upon request.

# OCM ANSI ROLLER CHAIN

Chain No. **35** Pitch • 0.375inch / 9.525mm

ROLLER CHAIN

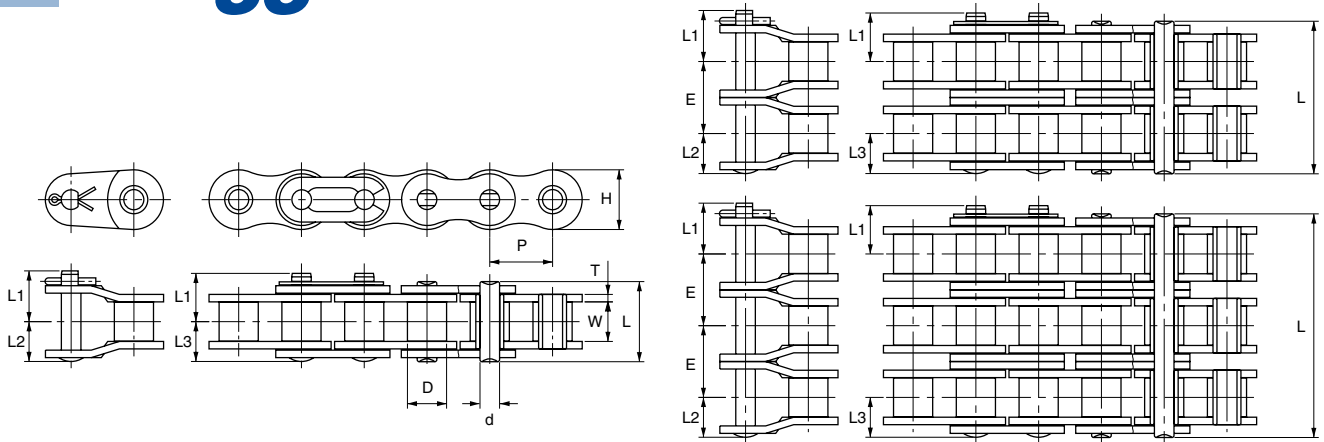

UNIT Upper:inch  
Beneath:mm

OCM Chain No.	ANSI No.	Pitch P	Roller Diam. D	Width between L.P. W		Link Plate H T		Pin Diam. d	Pin L L1 L2 L3				Trans Pitch E	Average Tensile Strength Lb/kg	Max. Working Load Lb/kg	Approx Weight Lb/ft kg/m
				H	T	L	L1		L2	L3						
OCM35	35	0.375 9.525	0.200 5.08	0.189 4.8	0.355 9.0	0.049 1.25	0.141 3.58	0.461 11.7	0.264 6.7	0.252 6.4	0.240 6.1	0.398 10.1	2,602 1,180	419 190	0.242 0.36	
OCM35-2	35-2	0.375 9.525	0.200 5.08	0.189 4.8	0.355 9.0	0.049 1.25	0.141 3.58	0.863 21.9	0.264 6.7	0.252 6.4	0.240 6.1	0.398 10.1	5,204 2,360	706 320	0.470 0.70	
OCM35-3	35-3	0.375 9.525	0.200 5.08	0.189 4.8	0.355 9.0	0.049 1.25	0.141 3.58	1.261 32.0	0.264 6.7	0.252 6.4	0.240 6.1	0.398 10.1	7,806 3,540	1,036 470	0.692 1.03	
OCM35-4	35-4	0.375 9.525	0.200 5.08	0.189 4.8	0.355 9.0	0.049 1.25	0.141 3.58	1.659 42.1	0.264 6.7	0.252 6.4	0.240 6.1	0.398 10.1	10,408 4,720	1,367 620	0.921 1.37	

1. Chain is rollerless. Available only in rivetted construction.  
Note: Dimensions subject to change. Certified dimensions furnished upon request.

## HORSEPOWER RATINGS SINGLE STRAND ROLLER CHAIN

No. of Teeth Small Spkt.	REVOLUTIONS PER MINUTE-SMALL SPROCKET																													
	50	100	300	500	700	900	1200	1500	1800	2100	2500	3000	3500	4000	4500	5000	5500	6000	6500	7000	7500	8000	8500	9000	10000					
11	0.10	0.18	0.49	0.77	1.05	1.31	1.70	2.08	2.45	2.82	3.30	2.94	2.33	1.91	1.60	1.37	1.18	1.04	0.92	0.82	0.74	0.67	0.62	0.57	0.48					
12	0.11	0.20	0.54	0.85	1.15	1.44	1.87	2.29	2.70	3.10	3.62	3.35	2.66	2.17	1.82	1.56	1.35	1.18	1.05	0.94	0.85	0.77	0.70	0.64	0.55					
13	0.12	0.22	0.59	0.93	1.26	1.57	2.04	2.49	2.94	3.38	3.95	3.77	3.00	2.45	2.05	1.75	1.52	1.33	1.18	1.06	0.95	0.87	0.79	0.73	0.62					
14	0.13	0.24	0.63	1.01	1.36	1.71	2.21	2.70	3.18	3.66	4.28	4.22	3.35	2.74	2.30	1.96	1.70	1.49	1.32	1.18	1.07	0.97	0.88	0.81	0.69					
15	0.14	0.25	0.68	1.08	1.47	1.84	2.38	2.91	3.43	3.94	4.61	4.68	3.71	3.04	2.55	2.17	1.88	1.65	1.47	1.31	1.18	1.07	0.98	0.90	0.77					
16	0.15	0.27	0.73	1.16	1.57	1.97	2.55	3.12	3.68	4.22	4.94	5.15	4.09	3.35	2.81	2.40	2.08	1.82	1.62	1.45	1.30	1.18	1.08	0.99	0.85					
17	0.16	0.29	0.78	1.24	1.68	2.10	2.73	3.33	3.93	4.51	5.28	5.64	4.48	3.67	3.07	2.62	2.27	2.00	1.77	1.58	1.43	1.30	1.18	1.09	0.93					
18	0.17	0.31	0.83	1.32	1.78	2.24	2.90	3.54	4.18	4.80	5.61	6.15	4.88	3.99	3.35	2.86	2.48	2.17	1.93	1.73	1.56	1.41	1.29	1.18	1.01					
19	0.18	0.33	0.88	1.40	1.89	2.37	3.07	3.76	4.43	5.09	5.95	6.67	5.29	4.33	3.63	3.10	2.69	2.36	2.09	1.87	1.69	1.53	1.40	1.28	1.10					
20	0.19	0.35	0.93	1.48	2.00	2.51	3.25	3.97	4.68	5.38	6.29	7.20	5.72	4.68	3.92	3.35	2.90	2.55	2.26	2.02	1.82	1.65	1.51	1.39	1.18					
21	0.20	0.37	0.98	1.56	2.11	2.64	3.42	4.19	4.93	5.67	6.63	7.75	6.15	5.03	4.22	3.60	3.12	2.74	2.43	2.17	1.96	1.78	1.62	1.49	1.27					
22	0.21	0.38	1.03	1.64	2.22	2.78	3.60	4.40	5.19	5.96	6.97	8.21	6.59	5.40	4.52	3.86	3.35	2.94	2.61	2.33	2.10	1.91	1.74	1.60	1.37					
23	0.22	0.40	1.08	1.72	2.33	2.92	3.78	4.62	5.44	6.25	7.31	8.62	7.05	5.77	4.83	4.13	3.58	3.14	2.79	2.49	2.25	2.04	1.86	1.71	1.46					
24	0.23	0.42	1.14	1.80	2.44	3.05	3.96	4.84	5.70	6.55	7.66	9.02	7.51	6.15	5.15	4.40	3.81	3.35	2.97	2.66	2.40	2.17	1.99	1.82	1.56					
25	0.24	0.44	1.19	1.88	2.55	3.19	4.13	5.05	5.95	6.84	8.00	9.43	7.99	6.54	5.48	4.68	4.05	3.56	3.16	2.82	2.55	2.31	2.11	1.94	1.65					
26	0.25	0.46	1.24	1.96	2.66	3.33	4.31	5.27	6.21	7.14	8.35	9.84	8.47	6.93	5.81	4.96	4.30	3.77	3.35	3.00	2.70	2.45	2.24	2.05	1.75					
28	0.27	0.50	1.34	2.12	2.88	3.61	4.67	5.71	6.73	7.73	9.05	10.7	9.47	7.75	6.49	5.55	4.81	4.22	3.74	3.35	3.02	2.74	2.50	2.30	1.96					
30	0.29	0.54	1.45	2.29	3.10	3.89	5.03	6.15	7.25	8.33	9.74	11.5	10.5	8.59	7.20	6.15	5.33	4.68	4.15	3.71	3.35	3.04	2.77	2.55	2.17					
32	0.31	0.58	1.55	2.45	3.32	4.17	5.40	6.60	7.77	8.93	10.4	12.3	11.6	9.47	7.93	6.77	5.87	5.15	4.57	4.09	3.69	3.35	3.06	2.81	0					
35	0.34	0.64	1.71	2.70	3.66	4.59	5.95	7.27	8.56	9.84	11.5	13.6	13.2	10.8	9.08	7.75	6.72	5.90	5.23	4.68	4.22	3.83	3.50	3.21	0					
40	0.39	0.73	1.97	3.12	4.23	5.30	6.87	8.40	9.89	11.4	13.3	15.7	16.2	13.2	11.1	9.47	8.21	7.20	6.39	5.72	5.15	4.68	0	0	0					
Lubri- cation	I					II										III														

See page 14. for lubrication type.  
For horsepower ratings of multiple strand, multiply the horsepower above by multiple strand factor on page 11.  
Note: Dimensions subject to change. Certified dimensions furnished upon request.

# OCM ANSI ROLLER CHAIN

Chain No. **41** Pitch • 0.500inch / 12.70mm

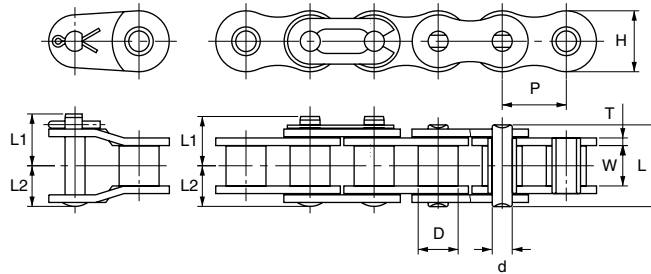

UNIT Upper:inch  
Beneath:mm

OCM Chain No.	ANSI No.	Pitch	Roller Diam.	Width between L.P.	Link Plate		Pin Diam.	Pin			Average Tensile Strength	Max. Working Load	Approx Weight
		P	D	W	H	T	d	L	L1	L2	Lb/kg	Lb/kg	Lb/ft kg/m
OCM41	41	0.500 12.70	0.306 7.77	0.252 6.4	0.382 9.7	0.049 1.25	0.141 3.58	0.524 13.3	0.315 8.0	0.268 6.8	2,392 1,090	463 210	0.273 0.41

1. No multiple strand is available.  
2. Available only in rivetted construction.  
Note: Dimensions subject to change. Certified dimensions furnished upon request.

## HORSEPOWER RATINGS SINGLE STRAND ROLLER CHAIN

No. of Teeth Small Spkt.	REVOLUTIONS PER MINUTE-SMALL SPROCKET																								
	10	25	50	100	200	300	400	500	700	900	1000	1200	1400	1600	1800	2100	2400	2700	3000	3500	4000	5000	6000	7000	8000
11	0.03	0.07	0.13	0.24	0.44	0.64	0.82	1.01	1.37	1.71	1.88	1.71	1.36	1.11	0.93	0.74	0.61	0.51	0.43	0.34	0.28	0.20	0.15	0.12	0.10
12	0.03	0.07	0.14	0.26	0.49	0.70	0.91	1.11	1.50	1.88	2.07	1.95	1.55	1.27	1.06	0.84	0.69	0.58	0.49	0.39	0.32	0.23	0.17	0.14	0.11
13	0.04	0.08	0.15	0.28	0.53	0.76	0.99	1.21	1.63	2.05	2.25	2.20	1.75	1.43	1.20	0.95	0.78	0.65	0.56	0.44	0.36	0.26	0.20	0.16	0.13
14	0.04	0.09	0.16	0.31	0.57	0.83	1.07	1.31	1.77	2.22	2.44	2.46	1.95	1.60	1.34	1.06	0.87	0.73	0.62	0.49	0.40	0.29	0.22	0.17	0.14
15	0.04	0.09	0.18	0.33	0.62	0.89	1.15	1.41	1.91	2.39	2.63	2.73	2.17	1.77	1.49	1.18	0.96	0.81	0.69	0.55	0.45	0.32	0.24	0.19	0.16
16	0.04	0.10	0.19	0.36	0.66	0.95	1.24	1.51	2.05	2.57	2.82	3.01	2.39	1.95	1.64	1.30	1.06	0.89	0.76	0.60	0.49	0.35	0.27	0.21	0.17
17	0.05	0.11	0.20	0.38	0.71	1.02	1.32	1.61	2.18	2.74	3.01	3.29	2.61	2.14	1.79	1.42	1.16	0.98	0.83	0.66	0.54	0.39	0.29	0.23	0.19
18	0.05	0.12	0.22	0.40	0.75	1.08	1.40	1.72	2.32	2.91	3.20	3.59	2.85	2.33	1.95	1.55	1.27	1.06	0.91	0.72	0.59	0.42	0.32	0.25	0
19	0.05	0.12	0.23	0.43	0.80	1.15	1.49	1.82	2.46	3.09	3.40	3.89	3.09	2.53	2.12	1.68	1.38	1.15	0.98	0.78	0.64	0.46	0.35	0.28	0
20	0.06	0.13	0.24	0.45	0.84	1.21	1.57	1.92	2.60	3.26	3.59	4.20	3.33	2.73	2.29	1.81	1.49	1.24	1.06	0.84	0.69	0.49	0.38	0.30	0
21	0.06	0.14	0.26	0.48	0.89	1.28	1.66	2.03	2.74	3.44	3.78	4.46	3.59	2.94	2.46	1.95	1.60	1.34	1.14	0.91	0.74	0.53	0.40	0.32	0
22	0.06	0.14	0.27	0.50	0.93	1.35	1.74	2.13	2.89	3.62	3.98	4.69	3.85	3.15	2.64	2.09	1.71	1.44	1.23	0.97	0.80	0.57	0.43	0.34	0
23	0.06	0.15	0.28	0.53	0.98	1.41	1.83	2.24	3.03	3.80	4.17	4.92	4.11	3.37	2.82	2.24	1.83	1.54	1.31	1.04	0.85	0.61	0.46	0.37	0
24	0.07	0.16	0.29	0.55	1.03	1.48	1.92	2.34	3.17	3.97	4.37	5.15	4.38	3.59	3.01	2.39	1.95	1.64	1.40	1.11	0.91	0.65	0.49	0.39	0
25	0.07	0.17	0.31	0.57	1.07	1.55	2.00	2.45	3.31	4.15	4.57	5.38	4.66	3.81	3.20	2.54	2.08	1.74	1.49	1.18	0.96	0.69	0.53	0	
26	0.07	0.17	0.32	0.60	1.12	1.61	2.09	2.55	3.46	4.33	4.76	5.61	4.94	4.05	3.39	2.69	2.20	1.85	1.58	1.25	1.02	0.73	0.56	0	
28	0.08	0.19	0.35	0.65	1.21	1.75	2.26	2.77	3.74	4.69	5.16	6.08	5.52	4.52	3.79	3.01	2.46	2.06	1.76	1.40	1.14	0.82	0.62	0	
30	0.08	0.20	0.38	0.70	1.31	1.88	2.44	2.98	4.03	5.06	5.56	6.55	6.13	5.01	4.20	3.33	2.73	2.29	1.95	1.55	1.27	0.91	0.69	0	
32	0.09	0.22	0.40	0.75	1.40	2.02	2.61	3.20	4.33	5.42	5.96	7.03	6.75	5.52	4.63	3.67	3.01	2.52	2.15	1.71	1.40	1.00	0		
35	0.10	0.24	0.44	0.83	1.54	2.22	2.88	3.52	4.76	5.97	6.57	7.74	7.72	6.32	5.29	4.20	3.44	2.88	2.46	1.95	1.60	1.14	0		
40	0.12	0.27	0.51	0.96	1.78	2.57	3.33	4.07	5.50	6.90	7.59	8.94	9.43	7.72	6.47	5.13	4.20	3.52	3.01	2.39	1.95	1.40	0		
Lubrication	I				II								III												

See page 14. for lubrication type.  
For horsepower ratings of multiple strand, multiply the horsepower above by multiple strand factor on page 11.  
Note: Dimensions subject to change. Certified dimensions furnished upon request.

# OCM ANSI ROLLER CHAIN

Chain No. **40** Pitch • 0.500inch / 12.70mm

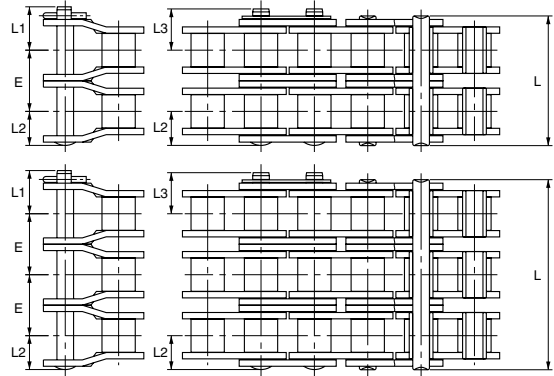
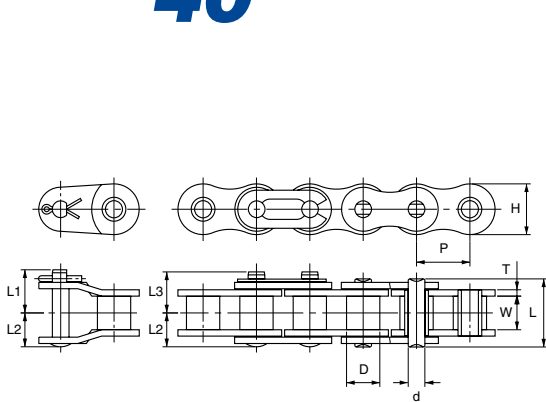

UNIT Upper:inch  
Beneath:mm

OCM Chain No.	ANSI No.	Pitch P	Roller Diam. D	Width between L.P. W	Link Plate		Pin Diam. d	Pin				Trans Pitch E	Average Tensile Strength	Max. Working Load	Approx Weight
					H	T		L	L1	L2	L3				
OCM40	40	0.500 12.70	0.313 7.94	0.313 7.95	0.473 12.0	0.059 1.5	0.156 3.96	0.634 16.1	0.402 10.2	0.319 8.1	0.382 9.7	0.567 14.4	4,300 1,950	860 390	0.443 0.66
OCM40-2	40-2	0.500 12.70	0.313 7.94	0.313 7.95	0.473 12.0	0.059 1.5	0.156 3.96	1.202 30.5	0.402 10.2	0.319 8.1	0.382 9.7	0.567 14.4	8,600 3,900	1,455 660	0.874 1.30
OCM40-3	40-3	0.500 12.70	0.313 7.94	0.313 7.95	0.473 12.0	0.059 1.5	0.156 3.96	1.773 45.0	0.402 10.2	0.319 8.1	0.382 9.7	0.567 14.4	12,900 5,850	2,139 970	1.304 1.94
OCM40-4	40-4	0.500 12.70	0.313 7.94	0.313 7.95	0.473 12.0	0.059 1.5	0.156 3.96	2.340 59.4	0.402 10.2	0.319 8.1	0.382 9.7	0.567 14.4	17,199 7,800	2,822 1,280	10.617 2.59
OCM40-5	40-5	0.500 12.70	0.313 7.94	0.313 7.95	0.473 12.0	0.059 1.5	0.156 3.96	2.908 73.8	0.402 10.2	0.319 8.1	0.382 9.7	0.567 14.4	21,499 9,750	3,352 1,520	2.170 3.23
OCM40-6	40-6	0.500 12.70	0.313 7.94	0.313 7.95	0.473 12.0	0.059 1.5	0.156 3.96	3.475 88.2	0.402 10.2	0.319 8.1	0.382 9.7	0.567 14.4	25,799 11,700	3,947 1,790	2.600 3.87

1. Rivetted construction is standard.  
Note: Dimensions subject to change. Certified dimensions furnished upon request.

## HORSEPOWER RATINGS SINGLE STRAND ROLLER CHAIN

No. of Teeth Small Spkt.	REVOLUTIONS PER MINUTE-SMALL SPROCKET (rpm)																								
	10	25	50	100	200	300	400	500	700	900	1000	1200	1400	1600	1800	2100	2400	2700	3000	3500	4000	5000	6000	7000	8000
11	0.11	0.26	0.49	0.91	1.70	2.45	3.18	3.89	5.26	6.59	6.80	6.80	6.80	5.57	4.67	3.70	3.03	2.54	2.17	1.72	1.41	1.01	0.77	0.61	0.50
12	0.13	0.29	0.54	1.00	1.87	2.70	3.49	4.27	5.78	7.24	7.60	7.60	7.60	6.34	5.32	4.22	3.45	2.89	2.47	1.96	1.60	1.15	0.87	0.69	0.57
13	0.14	0.31	0.59	1.09	2.04	2.94	3.81	4.65	6.30	7.90	8.29	8.29	8.29	7.15	6.00	4.76	3.89	3.26	2.79	2.21	1.81	1.29	0.99	0.78	0.64
14	0.15	0.34	0.63	1.18	2.21	3.18	4.12	5.04	6.82	8.56	8.98	8.98	8.98	7.99	6.70	5.32	4.35	3.65	3.11	2.47	2.02	1.45	1.10	0.87	0.72
15	0.16	0.37	0.68	1.28	2.38	3.43	4.44	5.43	7.35	9.22	9.67	9.67	9.67	8.86	7.43	5.90	4.83	4.04	3.45	2.74	2.24	1.60	1.22	0.97	0.79
16	0.17	0.39	0.73	1.37	2.55	3.68	4.76	5.82	7.88	9.88	10.4	10.4	10.4	9.76	8.19	6.50	5.32	4.46	3.80	3.02	2.47	1.77	1.35	1.07	0.87
17	0.18	0.42	0.78	1.46	2.73	3.93	5.09	6.22	8.42	10.6	11.1	11.1	11.1	10.7	8.97	7.11	5.82	4.88	4.17	3.31	2.71	1.94	1.47	1.17	0.96
18	0.20	0.45	0.83	1.55	2.90	4.18	5.41	6.61	8.95	11.2	11.8	11.8	11.8	11.7	9.77	7.75	6.34	5.32	4.54	3.60	2.95	2.11	1.60	1.27	0
19	0.21	0.47	0.88	1.65	3.07	4.43	5.74	7.01	9.49	11.9	12.6	12.6	12.6	12.6	10.6	8.41	6.88	5.77	4.92	3.91	3.20	2.29	1.74	1.38	0
20	0.22	0.50	0.93	1.74	3.25	4.68	6.06	7.41	10.0	12.6	13.7	13.7	13.7	13.7	11.4	9.08	7.43	6.23	5.32	4.22	3.45	2.47	1.88	1.49	0
21	0.23	0.53	0.98	1.84	3.42	4.93	6.39	7.81	10.6	13.3	14.6	14.8	14.8	14.8	12.3	9.77	7.99	6.70	5.72	4.54	3.72	2.66	2.02	1.60	0
22	0.24	0.55	1.03	1.93	3.60	5.19	6.72	8.21	11.1	13.9	15.3	15.7	15.7	15.7	13.2	10.5	8.57	7.18	6.13	4.87	3.98	2.85	2.17	1.72	0
23	0.25	0.58	1.08	2.02	3.78	5.44	7.05	8.62	11.7	14.6	16.1	16.9	16.9	16.9	14.1	11.2	9.16	7.68	6.56	5.20	4.26	3.05	2.32	1.84	0
24	0.27	0.61	1.14	2.12	3.96	5.70	7.38	9.02	12.2	15.3	16.8	18.0	18.0	18.0	15.0	11.9	9.77	8.19	6.99	5.55	4.54	3.25	2.47	1.96	0
25	0.28	0.64	1.19	2.22	4.13	5.95	7.71	9.43	12.8	16.0	17.6	18.9	18.9	18.9	16.0	12.7	10.4	8.70	7.43	5.90	4.83	3.45	2.63	0	
26	0.29	0.66	1.24	2.31	4.31	6.21	8.05	9.84	13.3	16.7	18.4	19.7	19.7	19.7	17.0	13.5	11.0	9.23	7.88	6.25	5.12	3.66	2.79	0	
28	0.32	0.72	1.34	2.50	4.67	6.73	8.72	10.7	14.4	18.1	19.9	21.5	21.5	21.5	19.0	15.0	12.3	10.3	8.81	6.99	5.72	4.09	3.11	0	
30	0.34	0.77	1.45	2.70	5.03	7.25	9.39	11.5	15.5	19.5	21.4	23.1	23.1	23.1	21.0	16.7	13.7	11.4	9.77	7.75	6.34	4.54	3.45	0	
32	0.36	0.83	1.55	2.89	5.40	7.77	10.1	12.3	16.7	20.9	23.0	24.7	24.7	24.7	23.2	18.4	15.0	12.6	10.8	8.54	6.99	5.00	0		
35	0.40	0.91	1.71	3.19	5.95	8.56	11.1	13.6	18.4	23.0	25.3	27.2	27.2	27.2	26.5	21.0	17.2	14.4	12.3	9.77	7.99	5.72	0		
40	0.46	1.06	1.97	3.68	6.87	9.89	12.8	15.7	21.2	26.6	29.2	32.3	32.3	32.3	32.3	25.7	21.0	17.6	15.0	11.9	9.77	6.99	0		
Lubri- cation	I						II						III												

Remarks) 1. For HP rating of multiple strand, multiply the HP above by multiple strand factor shown in the table at right.  
2. The operation in right part of the dotted line is not recommended.  
3. The lubrication type is as follows. Type I : Manual & Drip feed, Type II : Oil bath and Disc, Type III : Pump  
4. Dimensions & Ratings are subject to change without notice. Certified dimensions furnished upon request.

Number of Strands	2	3	4	5	6
Multiple Strand Factors	1.7	2.5	3.3	3.9	4.6

# OCM ANSI ROLLER CHAIN

Chain No. **50** Pitch • 0.625inch / 15.875mm

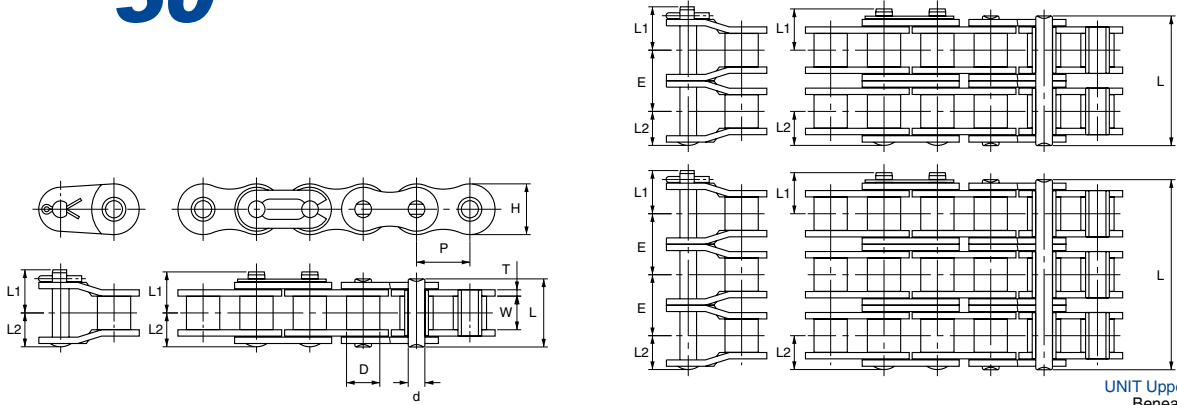

UNIT Upper:inch  
Beneath:mm

OCM Chain No.	ANSI No.	Pitch P	Roller Diam. D	Width between L.P. W		Link Plate H T		Pin Diam. d	Pin L L1 L2			Trans Pitch E	Average Tensile Strength Lb/kg	Max. Working Load Lb/kg	Approx Weight Lb/ft kg/m
				W	H	T	L		L1	L2					
OCM50	50	0.625 15.875	0.400 10.16	0.376 9.55	0.591 15.0	0.079 2.0	0.200 5.08	0.800 20.3	0.477 12.1	0.410 10.4	0.713 18.1	7,166 3,250	1,389 630	0.713 1.08	
OCM50-2	50-2	0.625 15.875	0.400 10.16	0.376 9.55	0.591 15.0	0.079 2.0	0.200 5.08	1.513 38.4	0.477 12.1	0.410 10.4	0.713 18.1	14,333 6,500	2,360 1,070	1.406 2.13	
OCM50-3	50-3	0.625 15.875	0.400 10.16	0.376 9.55	0.591 15.0	0.079 2.0	0.200 5.08	2.230 56.6	0.477 12.1	0.410 10.4	0.713 18.1	21,499 9,750	3,462 1,570	2.099 3.18	
OCM50-4	50-4	0.625 15.875	0.400 10.16	0.376 9.55	0.591 15.0	0.079 2.0	0.200 5.08	2.943 74.7	0.477 12.1	0.410 10.4	0.713 18.1	28,665 13,000	4,564 2,070	2.792 4.23	
OCM50-5	50-5	0.625 15.875	0.400 10.16	0.376 9.55	0.591 15.0	0.079 2.0	0.200 5.08	3.656 92.8	0.477 12.1	0.410 10.4	0.713 18.1	35,831 16,250	5,402 2,450	3.485 5.28	
OCM50-6	50-6	0.625 15.875	0.400 10.16	0.376 9.55	0.591 15.0	0.079 2.0	0.200 5.08	4.369 110.9	0.477 12.1	0.410 10.4	0.713 18.1	42,998 19,500	6,372 2,890	4.171 6.32	

1. Rivetted construction is standard.  
Note: Dimensions subject to change. Certified dimensions furnished upon request.

## HORSEPOWER RATINGS SINGLE STRAND ROLLER CHAIN

No. of Teeth Small Spkt.	REVOLUTIONS PER MINUTE-SMALL SPROCKET (rpm)																								
	10	25	50	100	200	300	400	500	700	900	1000	1200	1400	1600	1800	2100	2400	2700	3000	3500	4000	4500	5000	5500	6000
11	0.23	0.53	0.99	1.84	3.44	4.95	6.42	7.85	10.6	13.3	10.6	10.2	8.13	6.66	5.58	4.43	3.62	3.04	2.59	2.06	1.68	1.41	1.20	1.04	0.92
12	0.25	0.58	1.09	2.02	3.78	5.44	7.05	8.62	11.7	11.7	11.7	11.7	9.27	7.58	6.36	5.04	4.13	3.46	2.95	2.34	1.92	1.61	1.37	1.19	1.04
13	0.28	0.63	1.18	2.21	4.12	5.93	7.69	9.40	12.7	13.2	13.2	13.2	10.4	8.55	7.17	5.69	4.65	3.90	3.33	2.64	2.16	1.81	1.55	1.34	0
14	0.30	0.69	1.28	2.39	4.46	6.43	8.33	10.2	13.8	14.8	14.8	14.8	11.7	9.56	8.01	6.36	5.20	4.36	3.72	2.95	2.42	2.03	1.73	1.50	0
15	0.32	0.74	1.38	2.58	4.81	6.93	8.97	11.0	14.8	16.4	16.4	16.4	12.9	10.6	8.88	7.05	5.77	4.84	4.13	3.28	2.68	2.25	1.92	1.66	0
16	0.35	0.79	1.48	2.76	5.16	7.43	9.62	11.8	15.9	18.0	18.0	18.0	14.3	11.7	9.79	7.77	6.36	5.33	4.55	3.61	2.95	2.48	2.11	1.83	0
17	0.37	0.85	1.58	2.95	5.50	7.93	10.3	12.6	17.0	19.7	19.7	19.7	15.6	12.8	10.7	8.50	6.96	5.83	4.98	3.95	3.24	2.71	2.31	2.01	0
18	0.39	0.90	1.68	3.14	5.85	8.43	10.9	13.4	18.1	21.2	21.2	21.2	17.0	13.9	11.7	9.27	7.58	6.36	5.43	4.31	3.52	2.95	2.52	0	
19	0.42	0.96	1.78	3.33	6.21	8.94	11.6	14.2	19.2	22.5	22.5	22.5	18.5	15.1	12.7	10.0	8.22	6.89	5.89	4.67	3.82	3.20	2.74	0	
20	0.44	1.01	1.88	3.52	6.56	9.45	12.2	15.0	20.3	23.7	23.7	23.7	19.9	16.3	13.7	10.9	8.88	7.44	6.36	5.04	4.13	3.46	2.95	0	
21	0.47	1.06	1.99	3.71	6.91	9.96	12.9	15.8	21.4	25.1	25.1	25.1	21.5	17.6	14.7	11.7	9.56	8.01	6.84	5.43	4.44	3.72	3.18	0	
22	0.49	1.12	2.09	3.90	7.27	10.5	13.6	16.6	22.5	26.3	26.3	26.3	23.0	18.8	15.8	12.5	10.2	8.59	7.33	5.82	4.76	3.99	3.41	0	
23	0.51	1.17	2.19	4.09	7.63	11.0	14.2	17.4	23.6	27.6	27.6	27.6	24.6	20.1	16.9	13.4	11.0	9.18	7.84	6.22	5.09	4.27	0		
24	0.54	1.23	2.29	4.28	7.99	11.5	14.9	18.2	24.7	29.0	29.0	29.0	26.2	21.5	18.0	14.3	11.7	9.79	8.36	6.63	5.43	4.55	0		
25	0.56	1.28	2.40	4.47	8.35	12.0	15.6	19.0	25.8	30.2	30.2	30.2	27.9	22.8	19.1	15.2	12.4	10.4	8.88	7.05	5.77	4.84	0		
26	0.59	1.34	2.50	4.67	8.71	12.5	16.3	19.9	26.9	31.5	31.5	31.5	29.6	24.2	20.3	16.1	13.2	11.0	9.42	7.48	6.12	5.13	0		
28	0.64	1.45	2.71	5.06	9.43	13.6	17.6	21.5	29.1	34.2	34.2	34.2	33.0	27.0	22.7	18.0	14.7	12.3	10.5	8.36	6.84	5.73	0		
30	0.69	1.56	2.92	5.45	10.2	14.6	19.0	23.2	31.4	36.9	36.9	36.9	36.6	30.0	25.1	19.9	16.3	13.7	11.7	9.27	7.58	0			
32	0.74	1.68	3.13	5.84	10.9	15.7	20.3	24.9	33.7	40.4	40.4	40.4	40.4	33.0	27.7	22.0	18.0	15.1	12.9	10.2	8.36	0			
35	0.81	1.85	3.45	6.43	12.0	17.3	22.4	27.4	37.1	46.1	46.1	46.1	46.1	37.8	31.7	25.1	20.6	17.2	14.7	11.7	9.56	0			
40	0.94	2.13	3.98	7.43	13.9	20.0	25.9	31.6	42.8	53.7	56.5	56.5	56.5	46.2	38.7	30.7	25.1	21.1	18.0	14.3	0				

Lubri-cation	I	II		III	
--------------	---	----	--	-----	--

Remarks) 1. For HP rating of multiple strand, multiply the HP above by multiple strand factor shown in the table at right.  
2. The operation in right part of the dotted line is not recommended.  
3. The lubrication type is as follows. Type I : Manual & Drip feed, Type II : Oil bath and Disc, Type III : Pump  
4. Dimensions & Ratings are subject to change without notice. Certified dimensions furnished upon request.

Number of Strands	2	3	4	5	6
Multiple Strand Factors	1.7	2.5	3.3	3.9	4.6

# OCM ANSI ROLLER CHAIN

Chain No. **60** Pitch • 0.750inch / 19.05mm

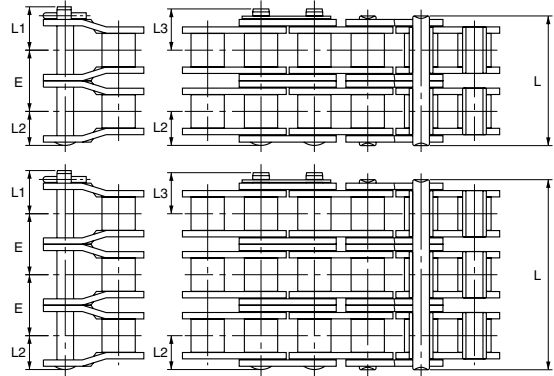
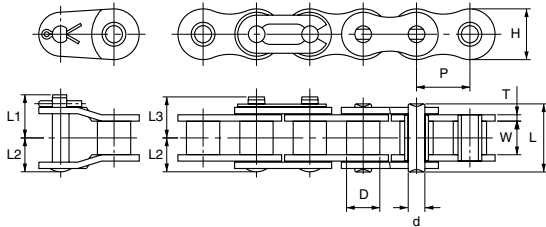

UNIT Upper:inch  
Beneath:mm

OCM Chain No.	ANSI No.	Pitch P	Roller Diam. D	Width between L.P. W		Link Plate H T		Pin Diam. d	Pin L L1 L2 L3				Trans Pitch E	Average Tensile Strength	Max. Working Load	Approx Weight
				Lb/kg	Lb/kg	Lb/kg	Lb/kg		Lb/kg	Lb/kg	Lb/kg					
OCM60	60	0.750 19.05	0.469 11.91	0.500 12.7	0.709 18.0	0.095 2.4	0.234 5.95	1.001 25.4	0.599 15.2	0.500 12.7	0.579 14.7	0.898 22.8	9,923 4,500	2,095 950	1.067 1.6	
OCM60-2	60-2	0.750 19.05	0.469 11.91	0.500 12.7	0.709 18.0	0.095 2.4	0.234 5.95	1.899 48.2	0.599 15.2	0.500 12.7	0.579 14.7	0.898 22.8	19,845 9,000	3,550 1,610	2.068 3.1	
OCM60-3	60-3	0.750 19.05	0.469 11.91	0.500 12.7	0.709 18.0	0.095 2.4	0.234 5.95	2.801 71.1	0.599 15.2	0.500 12.7	0.579 14.7	0.898 22.8	29,768 13,500	5,226 2,370	3.068 4.6	
OCM60-4	60-4	0.750 19.05	0.469 11.91	0.500 12.7	0.709 18.0	0.095 2.4	0.234 5.95	3.700 93.9	0.599 15.2	0.500 12.7	0.579 14.7	0.898 22.8	39,690 18,000	6,902 3,130	4.135 6.2	
OCM60-5	60-5	0.750 19.05	0.469 11.91	0.500 12.7	0.709 18.0	0.095 2.4	0.234 5.95	4.598 116.7	0.599 15.2	0.500 12.7	0.579 14.7	0.898 22.8	49,613 22,500	8,159 3,700	5.136 7.7	
OCM60-6	60-6	0.750 19.05	0.469 11.91	0.500 12.7	0.709 18.0	0.095 2.4	0.234 5.95	5.496 139.5	0.599 15.2	0.500 12.7	0.579 14.7	0.898 22.8	59,535 27,000	9,636 4,370	6.136 9.2	

1. Rivetted construction is standard.  
Note: Dimensions subject to change. Certified dimensions furnished upon request.

## HORSEPOWER RATINGS SINGLE STRAND ROLLER CHAIN

No. of Teeth Small Spkt.	REVOLUTIONS PER MINUTE-SMALL SPROCKET (rpm)																								
	10	25	50	100	150	200	300	400	500	600	700	800	900	1000	1100	1200	1400	1600	1800	2000	2500	3000	3500	4000	4500
11	0.42	0.96	1.79	3.34	4.80	6.22	8.96	11.6	14.2	16.7	17.0	17.0	17.0	15.6	13.5	11.9	9.41	7.70	6.45	5.51	3.94	3.00	2.38	1.95	1.63
12	0.46	1.05	1.96	3.66	5.28	6.84	9.85	12.8	15.6	18.4	18.6	18.6	18.6	17.8	15.4	13.5	10.7	8.78	7.35	6.28	4.49	3.42	2.71	2.22	1.86
13	0.50	1.15	2.14	3.99	5.75	7.45	10.7	13.9	17.0	20.0	20.4	20.4	20.4	20.0	17.4	15.2	12.1	9.89	8.29	7.08	5.07	3.85	3.06	2.50	0
14	0.54	1.24	2.32	4.33	6.23	8.08	11.6	15.1	18.4	21.7	22.4	22.4	22.4	22.4	19.4	17.0	13.5	11.1	9.27	7.91	5.66	4.31	3.42	2.80	0
15	0.59	1.34	2.50	4.66	6.72	8.70	12.5	16.2	19.8	23.4	24.8	24.8	24.8	24.8	21.5	18.9	15.0	12.3	10.3	8.78	6.28	4.78	3.79	3.10	0
16	0.63	1.44	2.68	5.00	7.20	9.33	13.4	17.4	21.3	25.1	27.4	27.4	27.4	27.4	23.7	20.8	16.5	13.5	11.3	9.67	6.92	5.26	4.18	3.42	0
17	0.67	1.53	2.86	5.34	7.69	9.96	14.3	18.6	22.7	26.8	29.9	29.9	29.9	29.9	26.0	22.8	18.1	14.8	12.4	10.6	7.58	5.76	4.57	3.74	0
18	0.71	1.63	3.04	5.68	8.18	10.6	15.3	19.8	24.2	28.5	31.8	31.8	31.8	31.8	28.3	24.8	19.7	16.1	13.5	11.5	8.25	6.28	4.98	4.08	0
19	0.76	1.73	3.23	6.02	8.67	11.2	16.2	21.0	25.6	30.2	33.7	33.7	33.7	33.7	30.7	26.9	21.4	17.5	14.7	12.5	8.95	6.81	5.40	4.42	0
20	0.80	1.83	3.41	6.36	9.16	11.9	17.1	22.2	27.1	31.9	35.7	35.7	35.7	35.7	33.1	29.1	23.1	18.9	15.8	13.5	9.67	7.35	5.84	0	
21	0.84	1.93	3.59	6.71	9.66	12.5	18.0	23.3	28.5	33.6	37.5	37.5	37.5	37.5	35.6	31.3	24.8	20.3	17.0	14.5	10.4	7.91	6.28	0	
22	0.89	2.02	3.78	7.05	10.2	13.2	19.0	24.6	30.0	35.4	39.6	39.6	39.6	39.6	38.2	33.5	26.6	21.8	18.3	15.6	11.2	8.48	6.73	0	
23	0.93	2.12	3.96	7.40	10.7	13.8	19.9	25.8	31.5	37.1	41.4	41.4	41.4	41.4	40.8	35.8	28.4	23.3	19.5	16.7	11.9	9.07	7.20	0	
24	0.98	2.22	4.15	7.75	11.2	14.5	20.8	27.0	33.0	38.8	43.6	43.6	43.6	43.6	43.6	38.2	30.3	24.8	20.8	17.8	12.7	9.67	7.67	0	
25	1.02	2.32	4.34	8.09	11.7	15.1	21.8	28.2	34.5	40.6	46.3	46.3	46.3	46.3	46.3	40.6	32.2	26.4	22.1	18.9	13.5	10.3	8.16	0	
26	1.06	2.43	4.53	8.44	12.2	15.8	22.7	29.4	35.9	42.4	48.7	49.1	49.1	49.1	49.1	43.1	34.2	28.0	23.5	20.0	14.3	10.9	8.65	0	
28	1.15	2.63	4.90	9.15	13.2	17.1	24.6	31.9	38.9	45.9	52.7	54.8	54.8	54.8	54.8	48.2	38.2	31.3	26.2	22.4	16.0	12.2	0	0	
30	1.24	2.83	5.28	9.86	14.2	18.4	26.5	34.3	42.0	49.4	56.8	60.2	60.2	60.2	60.2	53.4	42.4	34.7	29.1	24.8	17.8	13.5	0	0	
32	1.33	3.03	5.66	10.6	15.2	19.7	28.4	36.8	45.0	53.0	60.9	64.5	64.5	64.5	64.5	58.8	46.7	38.2	32.0	27.3	19.6	14.9	0	0	
35	1.47	3.34	6.24	11.6	16.8	21.7	31.3	40.5	49.6	58.4	67.1	71.1	71.1	71.1	71.1	67.3	53.4	43.7	36.6	31.3	22.4	17.0	0	0	
40	1.69	3.86	7.21	13.4	19.4	25.1	36.1	46.8	57.2	67.5	77.5	82.2	82.2	82.2	82.2	82.2	65.2	53.4	44.8	38.2	27.3	0	0	0	
Lubrication	I						II						III												

Remarks) 1. For HP rating of multiple strand, multiply the HP above by multiple strand factor shown in the table at right.  
2. The operation in right part of the dotted line is not recommended.  
3. The lubrication type is as follows. Type I : Manual & Drip feed, Type II : Oil bath and Disc, Type III : Pump  
4. Dimensions & Ratings are subject to change without notice. Certified dimensions furnished upon request.

Number of Strands	2	3	4	5	6
Multiple Strand Factors	1.7	2.5	3.3	3.9	4.6

# OCM ANSI ROLLER CHAIN

Chain No. **80** Pitch • 1.000inch / 25.40mm

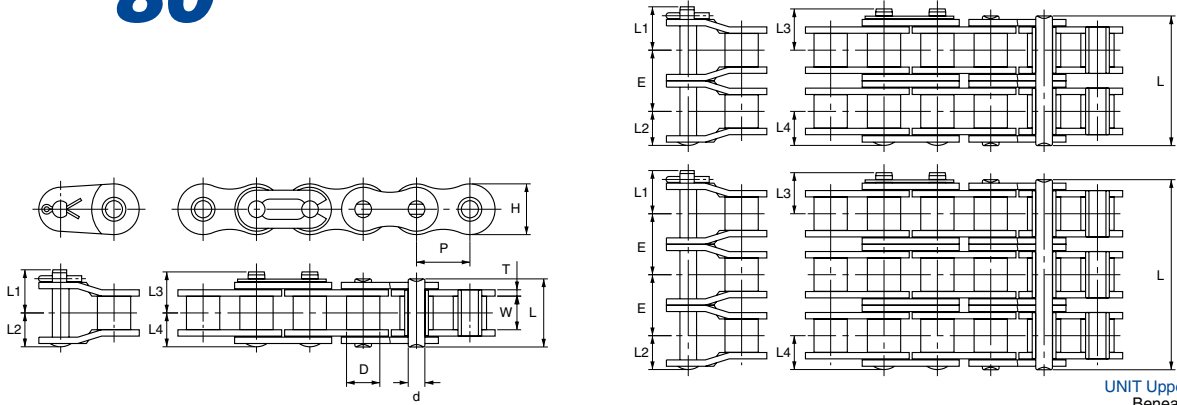

UNIT Upper:inch  
Beneath:mm

OCM Chain No.	ANSI No.	Pitch P	Roller Diam. D	Width between L.P. W		Link Plate H T		Pin Diam. d	Pin L L1 L2 L3 L4				Trans Pitch E	Average Tensile Strength Lb/kg	Max. Working Load Lb/kg	Approx Weight Lb/ft kg/m
				W	H	T	L		L1	L2	L3	L4				
OCM80	80	1.000 25.40	0.625 15.88	0.627 15.9	0.949 24.1	0.126 3.2	0.313 7.94	1.289 32.7	0.776 19.7	0.709 18.0	0.741 18.8	0.643 16.3	1.155 29.3	17,640 8,000	3,638 1,650	1.868 2.8
OCM80-2	80-2	1.000 25.40	0.625 15.88	0.627 15.9	0.949 24.1	0.126 3.2	0.313 7.94	2.447 62.1	0.776 19.7	0.709 18.0	0.741 18.8	0.643 16.3	1.155 29.3	35,280 16,000	6,185 2,805	3.735 5.6
OCM80-3	80-3	1.000 25.40	0.625 15.88	0.627 15.9	0.949 24.1	0.126 3.2	0.313 7.94	3.602 91.4	0.776 19.7	0.709 18.0	0.741 18.8	0.643 16.3	1.155 29.3	52,920 24,000	9,096 4,125	5.536 8.3
OCM80-4	80-4	1.000 25.40	0.625 15.88	0.627 15.9	0.949 24.1	0.126 3.2	0.313 7.94	4.756 120.7	0.776 19.7	0.709 18.0	0.741 18.8	0.643 16.3	1.155 29.3	70,560 32,000	12,006 5,445	7.337 11.0
OCM80-5	80-5	1.000 25.40	0.625 15.88	0.627 15.9	0.949 24.1	0.126 3.2	0.313 7.94	5.910 150.0	0.776 19.7	0.709 18.0	0.741 18.8	0.643 16.3	1.155 29.3	88,200 40,000	14,189 6,435	9.138 13.7
OCM80-6	80-6	1.000 25.40	0.625 15.88	0.627 15.9	0.949 24.1	0.126 3.2	0.313 7.94	7.065 179.3	0.776 19.7	0.709 18.0	0.741 18.8	0.643 16.3	1.155 29.3	105,840 48,000	16,736 7,590	10.939 16.4

1. Rivetted Construction is standard.  
Note: Dimensions subject to change. Certified dimensions furnished upon request.

## HORSEPOWER RATINGS SINGLE STRAND ROLLER CHAIN

No. of Teeth Small Spkt.	REVOLUTIONS PER MINUTE-SMALL SPROCKET (rpm)																											
	10	25	50	100	150	200	300	400	500	600	700	800	900	1000	1100	1200	1400	1600	1800	2000	2200	2400	2700	3000	3400			
11	0.97	2.22	4.14	7.72	11.1	14.4	20.8	26.9	30.3	30.3	27.4	23.0	19.6	17.0	14.9	11.84	9.69	8.12	6.94	6.01	5.28	4.42	3.78	3.13				
12	1.07	2.44	4.55	8.48	12.2	15.8	22.8	29.5	33.4	33.4	31.2	26.2	22.4	19.4	17.0	13.5	11.0	9.26	7.90	6.85	6.01	5.04	4.30	3.57				
13	1.16	2.66	4.96	9.25	13.3	17.3	24.9	32.2	36.3	36.3	35.2	29.5	25.2	21.8	19.2	15.2	12.5	10.4	8.91	7.72	6.78	5.68	4.85	4.02				
14	1.26	2.88	5.37	10.0	14.4	18.7	26.9	34.9	39.4	39.4	39.4	33.0	28.2	24.4	21.4	17.0	13.9	11.7	9.96	8.63	7.58	6.35	5.42	4.49				
15	1.36	3.10	5.79	10.8	15.6	20.1	29.0	37.6	43.7	43.7	43.7	36.6	31.2	27.1	23.8	18.9	15.4	12.9	11.0	9.57	8.40	7.04	6.01	4.98				
16	1.46	3.32	6.20	11.6	16.7	21.6	31.1	40.3	48.1	48.1	48.1	40.3	34.4	29.8	26.2	20.8	17.0	14.3	12.2	10.5	9.26	7.76	6.62	5.49				
17	1.56	3.55	6.62	12.4	17.8	23.1	33.2	43.0	52.6	52.7	52.7	44.1	37.7	32.7	28.7	22.8	18.6	15.6	13.3	11.6	10.1	8.50	7.25	0				
18	1.66	3.78	7.05	13.1	18.9	24.5	35.3	45.8	56.0	57.4	57.4	48.1	41.1	35.6	31.2	24.8	20.3	17.0	14.5	12.6	11.0	9.26	7.90	0				
19	1.75	4.00	7.47	13.9	20.1	26.0	37.5	48.5	59.3	61.7	61.7	52.2	44.5	38.6	33.9	26.9	22.0	18.4	15.7	13.6	12.0	10.0	8.57	0				
20	1.85	4.23	7.89	14.7	21.2	27.5	39.6	51.3	62.7	65.3	65.3	56.3	48.1	41.7	36.6	29.0	23.8	19.9	17.0	14.7	12.9	10.8	9.26	0				
21	1.95	4.46	8.32	15.5	22.4	29.0	41.7	54.1	66.1	68.8	68.8	60.6	51.8	44.9	39.4	31.2	25.6	21.4	18.3	15.9	13.9	11.7	9.96	0				
22	2.06	4.69	8.75	16.3	23.5	30.5	43.9	56.9	69.5	72.3	72.3	65.0	55.5	48.1	42.2	33.5	27.4	23.0	19.6	17.0	14.9	12.5	10.7	0				
23	2.16	4.92	9.18	17.1	24.7	32.0	46.0	59.7	72.9	75.9	75.9	69.5	59.3	51.4	45.1	35.8	29.3	24.6	21.0	18.2	16.0	13.4	11.4	0				
24	2.26	5.15	9.61	17.9	25.8	33.5	48.2	62.5	76.4	79.5	79.5	74.1	63.2	54.8	48.1	38.2	31.2	26.2	22.4	19.4	17.0	14.3	12.2	0				
25	2.36	5.38	10.0	18.7	27.0	35.0	50.4	65.3	79.8	83.0	83.0	83.0	78.7	67.2	58.3	51.1	40.6	33.2	27.8	23.8	20.6	18.1	15.2	0				
26	2.46	5.62	10.5	19.6	28.2	36.5	52.6	68.1	83.2	86.6	86.6	86.6	83.5	71.3	61.8	54.2	43.0	35.2	29.5	25.2	21.8	19.2	16.1	0				
28	2.67	6.08	11.4	21.2	30.5	39.5	56.9	73.8	90.2	93.9	93.9	93.9	93.3	79.7	69.1	60.6	48.1	39.4	33.0	28.2	24.4	21.4	18.0	0				
30	2.87	6.55	12.2	22.8	32.9	42.6	61.4	79.5	97.2	104	104	104	104	88.4	76.6	67.2	53.3	43.7	36.6	31.2	27.1	23.8	19.9	0				
32	3.08	7.03	13.1	24.5	35.3	45.7	65.8	85.2	104	114	114	114	114	97.4	84.4	74.1	58.8	48.1	40.3	34.4	29.8	26.2	0					
35	3.39	7.74	14.4	27.0	38.8	50.3	72.5	93.9	115	130	130	130	130	111	96.5	84.7	67.2	55.0	46.1	39.4	34.1	30.0	0					
40	3.92	8.94	16.7	31.1	44.9	58.1	83.7	108	133	153	153	153	153	136	118	103	82.1	67.2	56.3	48.1	41.7	0						

Lubri-cation	I	II	III
--------------	---	----	-----

Remarks) 1. For HP rating of multiple strand, multiply the HP above by multiple strand factor shown in the table at right.  
2. The operation in right part of the dotted line is not recommended.  
3. The lubrication type is as follows. Type I : Manual & Drip feed, Type II : Oil bath and Disc, Type III : Pump  
4. Dimensions & Ratings are subject to change without notice. Certified dimensions furnished upon request.

Number of Strands	2	3	4	5	6
Multiple Strand Factors	1.7	2.5	3.3	3.9	4.6



# OCM ANSI ROLLER CHAIN

Chain No. **100** Pitch • 1.250inch / 31.75mm

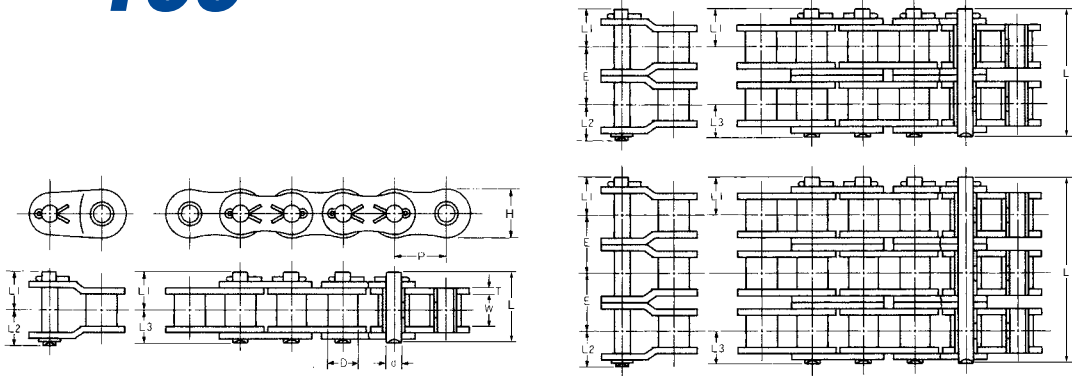

UNIT Upper:inch  
Beneath:mm

OCM Chain No.	ANSI No.	Pitch P	Roller Diam. D	Width between L.P. W		Link Plate		Pin Diam. d	Pin				Trans Pitch E	Average Tensile Strength Lb/kg	Max. Working Load Lb/kg	Approx Weight Lb/ft kg/m
				H	T	L	L1		L2	L3						
OCM100	100	1.250	0.750	0.755	1.185	0.158	0.375	1.698	0.925	0.846	0.787	1.411	26,460	5,513	2.801	
		31.75	19.05	19.15	30.1	4.0	9.53	43.1	23.5	21.5	20.0	35.8	12,000	2,500	4.2	
OCM100-2	100-2	1.250	0.750	0.755	1.185	0.158	0.375	3.109	0.925	0.846	0.787	1.411	52,920	9,371	5.603	
		31.75	19.05	19.15	30.1	4.0	9.53	78.9	23.5	21.5	20.0	35.8	24,000	4,250	8.4	
OCM100-3	100-3	1.250	0.750	0.755	1.185	0.158	0.375	4.519	0.925	0.846	0.787	1.411	79,380	13,781	8.338	
		31.75	19.05	19.15	30.1	4.0	9.53	114.7	23.5	21.5	20.0	35.8	36,000	6,250	12.5	
OCM100-4	100-4	1.250	0.750	0.755	1.185	0.158	0.375	5.930	0.925	0.846	0.787	1.411	105,840	18,191	11.006	
		31.75	19.05	19.15	30.1	4.0	9.53	150.5	23.5	21.5	20.0	35.8	48,000	8,250	16.5	
OCM100-5	100-5	1.250	0.750	0.755	1.185	0.158	0.375	7.340	0.925	0.846	0.787	1.411	132,300	21,499	13.807	
		31.75	19.05	19.15	30.1	4.0	9.53	186.3	23.5	21.5	20.0	35.8	60,000	9,750	20.7	
OCM100-6	100-6	1.250	0.750	0.755	1.185	0.158	0.375	8.751	0.925	0.846	0.787	1.411	158,760	25,358	16.542	
		31.75	19.05	19.15	30.1	4.0	9.53	222.1	23.5	21.5	20.0	35.8	72,000	11,500	24.8	

Note: Dimensions subject to change. Certified dimensions furnished upon request.

## HORSEPOWER RATINGS SINGLE STRAND ROLLER CHAIN

No. of Teeth Small Spkt.	REVOLUTIONS PER MINUTE-SMALL SPROCKET (rpm)																									
	10	25	50	100	200	300	400	500	600	700	800	900	1000	1100	1200	1300	1400	1600	1800	2000	2200	2400	2500	2600		
11	1.07	2.45	4.57	8.53	16.0	22.9	29.6	36.3	42.8	40.1	32.7	27.5	23.5	20.4	17.8	15.8	14.2	11.59	9.71	8.29	7.19	6.30	5.93	5.59		
12	1.18	2.68	5.02	9.36	17.4	25.2	32.6	39.8	46.9	45.6	37.4	31.2	26.7	23.2	20.4	18.0	16.1	13.21	11.1	9.45	8.19	7.19	6.73	0		
13	1.29	2.94	5.47	10.2	19.0	27.5	35.5	43.4	51.2	51.5	42.1	35.3	30.2	26.1	22.9	20.4	18.2	14.9	12.5	10.6	9.24	8.10	7.62	0		
14	1.39	3.18	5.93	11.1	20.7	29.8	38.5	47.1	55.5	57.5	47.1	39.4	33.7	29.2	25.6	22.7	20.4	16.6	13.9	11.9	10.3	9.05	8.52	0		
15	1.50	3.42	6.38	11.9	22.3	32.0	41.4	50.7	59.8	63.8	52.2	43.7	37.4	32.3	28.4	25.2	22.5	18.5	15.4	13.2	11.5	10.0	0	0		
16	1.61	3.67	6.84	12.8	23.9	34.3	44.5	54.3	64.1	70.3	57.5	48.1	41.2	35.7	31.2	27.8	24.8	20.4	17.0	14.5	12.6	11.1	0	0		
17	1.72	3.92	7.31	13.7	25.5	36.6	47.5	58.1	68.4	77.0	63.0	52.8	45.1	39.0	34.3	30.4	27.2	22.3	18.6	16.0	13.8	12.1	0	0		
18	1.82	4.17	7.78	14.5	27.1	39.0	50.6	61.7	72.8	83.5	68.7	57.5	49.1	42.5	37.4	33.1	29.6	24.3	20.4	17.3	15.0	0	0	0		
19	1.93	4.41	8.25	15.4	28.7	41.3	53.5	65.4	77.1	88.6	74.4	62.4	53.2	46.1	40.5	35.9	32.2	26.3	22.0	18.8	16.4	0	0	0		
20	2.05	4.67	8.72	16.2	30.3	43.7	56.6	69.2	81.5	93.6	80.3	67.3	57.5	49.9	43.7	38.8	34.7	28.4	23.9	20.4	17.6	0	0	0		
21	2.16	4.92	9.19	17.2	31.9	46.0	59.7	73.0	86.0	98.7	86.5	72.4	61.8	53.6	47.1	41.7	37.4	30.6	25.6	21.9	18.9	0	0	0		
22	2.27	5.18	9.66	18.0	33.7	48.4	62.8	76.7	90.4	104	92.7	77.6	66.4	57.5	50.4	44.8	40.1	32.7	27.5	23.5	20.4	0	0	0		
23	2.37	5.43	10.1	18.9	35.3	50.8	65.8	80.5	94.8	109	99.1	83.0	70.9	61.4	53.9	47.9	42.8	35.0	29.4	25.1	20.7	0	0	0		
24	2.49	5.69	10.6	19.8	36.9	53.2	68.9	84.2	99.2	114	106	88.5	75.6	65.6	57.5	51.0	45.6	37.4	31.2	26.7	0	0	0	0		
25	2.60	5.94	11.1	20.7	38.6	55.7	72.0	88.1	104	119	112	94.1	80.3	69.6	61.1	54.2	48.5	39.7	33.3	28.4	0	0	0	0		
26	2.72	6.20	11.6	21.6	40.2	58.1	75.1	91.9	108	124	119	99.8	85.3	73.9	64.9	57.5	51.5	42.1	35.3	30.2	0	0	0	0		
28	2.94	6.72	12.5	23.3	43.6	62.9	81.4	99.5	117	134	133	112	95.2	82.6	72.4	64.2	57.5	47.1	39.4	33.7	0	0	0	0		
30	3.16	7.23	13.5	25.2	46.9	67.7	87.7	107.1	126	145	148	124	106	91.6	80.3	71.2	63.8	52.2	43.7	0	0	0	0	0		
32	3.41	7.75	14.5	27.0	50.4	72.5	94.0	115	135	156	162	137	116	101	88.5	78.4	70.3	57.5	48.1	0	0	0	0	0		
35	3.74	8.54	16.0	29.8	55.5	79.9	104	127	149	172	186	156	133	115	101	89.8	80.3	65.7	55.1	0	0	0	0	0		
40	4.33	9.87	18.4	34.3	64.1	92.4	120	146	173	198	224	190	162	141	124	110	98.2	80.3	0	0	0	0	0	0		
Lubri-cation	I					II										III										

Remarks) 1. For HP rating of multiple strand, multiply the HP above by multiple strand factor shown in the table at right.  
 2. The operation in right part of the dotted line is not recommended.  
 3. The lubrication type is as follows. Type I : Manual & Drip feed, Type II : Oil bath and Disc, Type III : Pump  
 4. Dimensions & Ratings are subject to change without notice. Certified dimensions furnished upon request.

Number of Strands	2	3	4	5	6
Multiple Strand Factors	1.7	2.5	3.3	3.9	4.6

# OCM ANSI ROLLER CHAIN

Chain No. **120** Pitch • 1.500inch / 38.10mm

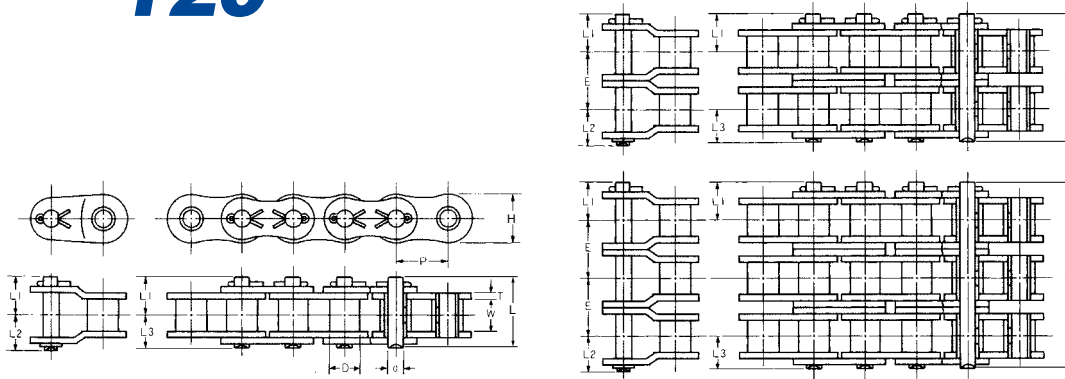

UNIT Upper:inch  
Beneath:mm

OCM Chain No.	ANSI No.	Pitch P	Roller Diam. D	Width between L.P. W	Link Plate		Pin Diam. d	Pin				Trans Pitch E	Average Tensile Strength Lb/kg	Max. Working Load Lb/kg	Approx Weight Lb/ft kg/m
					H	T		L	L1	L2	L3				
OCM120	120	1.500 38.10	0.876 22.23	1.007 25.55	1.425 36.2	0.189 4.8	0.438 11.11	2.124 53.9	1.119 28.4	1.071 27.2	0.989 25.1	1.789 45.4	37,044 16,800	7,277 3,300	4.135 6.2
OCM120-2	120-2	1.500 38.10	0.876 22.23	1.007 25.55	1.425 36.2	0.189 4.8	0.438 11.11	3.897 98.9	1.119 28.4	1.071 27.2	0.989 25.1	1.789 45.4	74,088 33,600	12,370 5,610	8.137 12.2
OCM120-3	120-3	1.500 38.10	0.876 22.23	1.007 25.55	1.425 36.2	0.189 4.8	0.438 11.11	5.685 144.3	1.119 28.4	1.071 27.2	0.989 25.1	1.789 45.4	111,132 50,400	18,191 8,250	12.206 18.3
OCM120-4	120-4	1.500 38.10	0.876 22.23	1.007 25.55	1.425 36.2	0.189 4.8	0.438 11.11	7.474 189.7	1.119 28.4	1.071 27.2	0.989 25.1	1.789 45.4	148,176 67,200	24,012 10,890	16.342 24.5
OCM120-5	120-5	1.500 38.10	0.876 22.23	1.007 25.55	1.425 36.2	0.189 4.8	0.438 11.11	9.263 235.1	1.119 28.4	1.071 27.2	0.989 25.1	1.789 45.4	185,220 84,000	28,378 12,870	20.410 30.6
OCM120-6	120-6	1.500 38.10	0.876 22.23	1.007 25.55	1.425 36.2	0.189 4.8	0.438 11.11	11.052 280.5	1.119 28.4	1.071 27.2	0.989 25.1	1.789 45.4	222,264 100,800	33,472 15,180	24.546 36.8

Note: Dimensions subject to change. Certified dimensions furnished upon request.

## HORSEPOWER RATINGS SINGLE STRAND ROLLER CHAIN

No. of Teeth Small Spkt.	REVOLUTIONS PER MINUTE-SMALL SPROCKET (rpm)																								
	10	25	50	100	150	200	300	400	500	600	700	800	900	1000	1100	1200	1300	1400	1500	1600	1700	1800	1900	2000	2100
11	1.85	4.22	7.87	14.8	21.2	27.4	39.4	51.1	62.5	58.3	46.4	38.0	31.8	27.1	23.5	20.7	18.4	16.4	14.8	13.4	12.24	11.2	10.4	9.59	0
12	2.04	4.64	8.65	16.1	23.2	30.2	43.3	56.2	68.7	66.5	52.8	43.2	36.2	31.0	26.8	23.5	20.9	18.6	16.9	15.3	13.9	12.8	11.8	10.9	0
13	2.21	5.06	9.43	17.6	25.3	32.9	47.3	61.3	75.0	75.0	59.5	48.7	40.9	34.9	30.2	26.6	23.5	21.1	19.0	17.2	15.7	14.5	13.3	0	0
14	2.40	5.47	10.2	19.0	27.5	35.5	51.2	66.4	81.1	83.8	66.5	54.4	45.6	39.0	33.8	29.6	26.3	23.5	21.2	19.3	17.6	16.1	14.9	0	0
15	2.59	5.90	11.0	20.5	29.6	38.4	55.2	71.5	87.4	92.9	73.8	60.3	50.6	43.2	37.4	32.9	29.1	26.1	23.5	21.3	19.4	17.8	16.5	0	0
16	2.78	6.33	11.8	22.0	31.8	41.0	59.1	76.7	93.7	102	81.3	66.5	55.8	47.6	41.3	36.2	32.2	28.7	25.9	23.5	21.5	19.7	0	0	0
17	2.96	6.75	12.6	23.5	33.9	43.9	63.2	81.8	100	112	89.0	72.8	61.0	52.2	45.2	39.7	35.1	31.5	28.4	25.7	23.5	21.6	0	0	0
18	3.15	7.17	13.4	24.9	36.1	46.7	67.2	87.0	106	122	97.0	79.4	66.5	56.9	49.2	43.2	38.4	34.3	31.0	28.0	25.6	23.5	0	0	0
19	3.34	7.62	14.2	26.6	38.2	49.5	71.2	92.3	113	132	105	86.1	72.1	61.6	53.4	46.8	41.6	37.1	33.5	30.4	27.8	25.5	0	0	0
20	3.53	8.05	15.0	28.0	40.4	52.3	75.4	97.6	119	141	114	92.9	77.9	66.5	57.7	50.6	44.9	40.2	36.2	32.9	30.0	20.4	0	0	0
21	3.71	8.48	15.8	29.5	42.5	55.1	79.4	103	126	148	122	100	83.8	71.6	62.1	54.4	48.3	43.2	39.0	35.4	32.3	0	0	0	0
22	3.92	8.92	16.6	31.1	44.8	57.9	83.5	108	132	156	131	107	89.8	76.7	66.5	58.3	51.8	46.4	41.8	38.0	34.6	0	0	0	0
23	4.10	9.36	17.4	32.6	46.9	60.7	87.6	113	138	164	139	115	96.1	82.1	71.1	62.4	55.4	49.5	44.7	40.5	37.0	0	0	0	0
24	4.29	9.80	18.2	34.1	49.1	63.7	91.7	119	145	172	149	122	102	87.4	75.8	66.5	59.0	52.8	47.6	43.2	28.8	0	0	0	0
25	4.49	10.2	19.0	35.7	51.4	66.5	95.9	124	152	178	158	130	109	92.9	80.6	70.7	62.8	56.2	50.6	46.0	0	0	0	0	0
26	4.68	10.7	20.0	37.1	53.6	69.5	100	130	158	186	169	138	115	98.6	85.4	75.0	66.5	59.5	53.6	48.7	0	0	0	0	0
28	5.07	11.6	21.6	40.4	58.1	75.2	108	141	172	202	188	154	129	110	95.5	83.8	74.3	66.5	59.9	41.4	0	0	0	0	0
30	5.47	12.5	23.2	43.4	62.5	81.0	117	152	185	217	209	170	143	122	106	92.9	82.5	73.8	66.5	0	0	0	0	0	0
32	5.86	13.4	24.9	46.5	67.1	86.9	125	162	198	233	229	188	158	134	117	102	90.8	81.3	59.0	0	0	0	0	0	0
35	6.45	14.8	27.5	51.2	73.9	95.7	138	178	219	257	263	216	181	154	134	117	104	92.9	0	0	0	0	0	0	0
40	7.46	17.0	31.8	59.3	85.3	110	160	207	252	298	322	263	220	188	164	143	112	0	0	0	0	0	0	0	0

Lubri-cation	I	II	III
--------------	---	----	-----

Remarks) 1. For HP rating of multiple strand, multiply the HP above by multiple strand factor shown in the table at right.  
 2. The operation in right part of the dotted line is not recommended.  
 3. The lubrication type is as follows. Type I: Manual & Drip feed, Type II: Oil bath and Disc, Type III: Pump  
 4. Dimensions & Ratings are subject to change without notice. Certified dimensions furnished upon request.

Number of Strands	2	3	4	5	6
Multiple Strand Factors	1.7	2.5	3.3	3.9	4.6

# OCM ANSI ROLLER CHAIN

Chain No. **140** Pitch • 1.750inch / 44.45mm

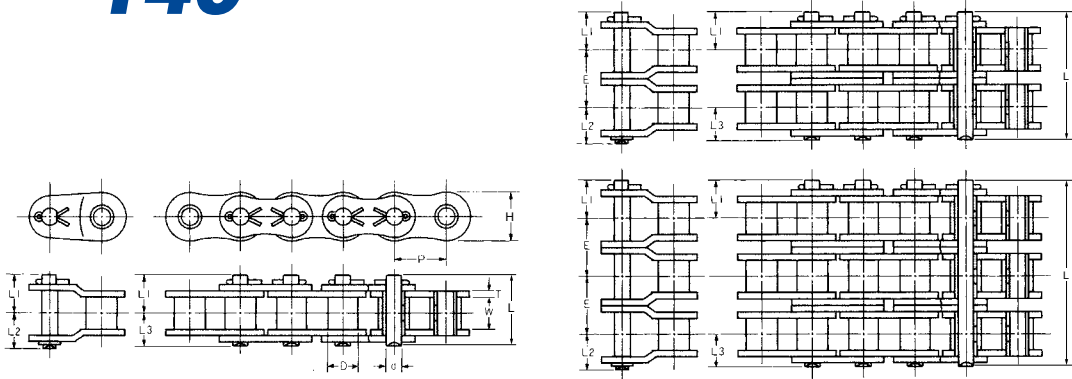

UNIT Upper:inch  
Beneath:mm

OCM Chain No.	ANSI No.	Pitch P	Roller Diam. D	Width between L.P.		Link Plate		Pin Diam. d	Pin				Trans Pitch E	Average Tensile Strength Lb/kg	Max. Working Load Lb/kg	Approx Weight Lb/ft kg/m
				W	H	T	L		L1	L2	L3					
OCM140	140	1.750	1.000	1.000	1.663	0.220	0.500	2.321	1.253	1.150	1.068	1.927	48,731	9,702	5.136	
		44.45	25.40	25.40	42.2	5.6	12.70	58.9	31.8	29.2	27.1	48.9	22,100	4,400	7.7	
OCM140-2	140-2	1.750	1.000	1.000	1.663	0.220	0.500	4.247	1.253	1.150	1.068	1.927	97,461	16,493	10.072	
		44.45	25.40	25.40	42.2	5.6	12.70	107.8	31.8	29.2	27.1	48.9	44,200	7,480	15.1	
OCM140-3	140-3	1.750	1.000	1.000	1.663	0.220	0.500	6.174	1.253	1.150	1.068	1.927	146,192	24,255	15.074	
		44.45	25.40	25.40	42.2	5.6	12.70	156.7	31.8	29.2	27.1	48.9	66,300	11,000	22.6	
OCM140-4	140-4	1.750	1.000	1.000	1.663	0.220	0.500	8.101	1.253	1.150	1.068	1.927	194,922	32,017	20.077	
		44.45	25.40	25.40	42.2	5.6	12.70	205.6	31.8	29.2	27.1	48.9	88,400	14,520	30.1	
OCM140-5	140-5	1.750	1.000	1.000	1.663	0.220	0.500	10.027	1.253	1.150	1.068	1.927	243,653	37,838	25.013	
		44.45	25.40	25.40	42.2	5.6	12.70	254.5	31.8	29.2	27.1	48.9	110,500	17,160	37.5	
OCM140-6	140-6	1.750	1.000	1.000	1.663	0.220	0.500	11.954	1.253	1.150	1.068	1.927	292,383	44,629	30.015	
		44.45	25.40	25.40	42.2	5.6	12.70	303.4	31.8	29.2	27.1	48.9	132,600	20,240	45.0	

Note: Dimensions subject to change. Certified dimensions furnished upon request.

## HORSEPOWER RATINGS SINGLE STRAND ROLLER CHAIN

No. of Teeth Small Splt.	REVOLUTIONS PER MINUTE-SMALL SPROCKET (rpm)																								
	10	25	50	100	150	200	250	300	350	400	450	500	550	600	700	800	900	1000	1100	1200	1300	1400	1500	1600	1700
11	2.88	6.56	12.2	22.8	33.0	42.6	52.2	61.4	70.5	79.7	88.5	86.9	75.2	66.1	52.4	42.9	35.9	30.7	26.6	23.3	20.7	18.5	16.8	15.2	6.36
12	3.16	7.21	13.4	25.1	36.2	46.8	57.3	67.5	77.5	87.4	97.2	99.0	85.8	75.2	59.7	48.9	41.0	35.0	30.3	26.6	23.6	21.1	19.0	16.2	0
13	3.45	7.86	14.6	27.4	39.4	51.1	62.5	73.6	84.5	95.3	106	112	96.7	84.9	67.3	55.1	46.1	39.4	34.2	30.0	26.6	23.9	21.5	10.9	0
14	3.73	8.52	16.0	29.6	42.8	55.4	67.6	79.7	91.6	103	115	125	108	94.8	75.2	61.6	51.6	44.1	38.2	33.5	29.8	26.6	24.0	0	0
15	4.02	9.17	17.2	31.9	46.0	59.7	73.0	85.8	98.7	111	124	135	120	105	83.4	68.3	57.3	48.9	42.4	37.1	33.0	29.5	26.6	0	0
16	4.32	9.84	18.4	34.2	49.3	64.0	78.2	92.1	106	119	133	146	132	116	92.0	75.2	63.0	53.9	46.7	41.0	36.3	32.5	29.4	0	0
17	4.60	10.5	19.6	36.6	52.7	68.3	83.4	98.3	113	127	142	156	145	127	101	82.5	69.1	59.0	51.1	44.9	39.8	35.7	24.1	0	0
18	4.89	11.2	20.8	38.9	56.1	72.5	88.8	105	120	135	150	165	157	138	110	89.8	75.2	64.2	55.7	48.9	43.3	38.8	16.9	0	0
19	5.19	11.8	22.1	41.3	59.4	77.0	94.1	111	127	143	160	176	170	150	119	97.4	81.7	69.7	60.3	53.0	47.1	42.1	0	0	0
20	5.48	12.5	23.3	43.6	62.8	81.4	99.5	117	134	152	169	185	185	162	128	105	88.1	75.2	65.2	57.3	50.8	45.5	0	0	0
21	5.78	13.2	24.7	46.0	66.2	85.7	105	124	142	160	178	196	198	174	138	113	94.8	81.0	70.1	61.6	54.6	43.7	0	0	0
22	6.09	13.8	25.9	48.3	69.6	90.1	110	130	149	168	188	205	213	186	149	121	102	86.9	75.2	66.1	58.6	35.9	0	0	0
23	6.38	14.6	27.2	50.7	73.1	94.5	116	137	157	177	196	216	228	200	158	130	109	92.8	80.5	70.7	62.6	27.2	0	0	0
24	6.68	15.3	28.4	53.1	76.4	99.1	121	142	164	185	205	225	243	213	169	138	116	99.0	85.8	75.2	66.8	0	0	0	0
25	6.99	16.0	29.8	55.5	79.9	104	127	149	172	193	215	236	257	227	180	148	123	105	91.2	80.1	70.3	0	0	0	0
26	7.28	16.6	31.0	57.9	83.4	108	132	156	178	201	224	247	268	240	190	156	131	112	96.7	84.9	62.4	0	0	0	0
28	7.90	18.0	33.7	62.8	90.2	117	143	169	193	219	243	267	291	268	213	174	146	125	108	94.8	43.7	0	0	0	0
30	8.50	19.4	36.2	67.6	97.4	126	154	181	209	235	261	287	314	298	236	193	162	138	120	96.4	0	0	0	0	0
32	9.12	20.8	38.8	72.4	104	135	165	194	224	252	280	308	335	327	260	213	178	153	132	78.2	0	0	0	0	0
35	10.0	22.9	42.8	79.8	115	149	182	215	247	278	308	339	370	375	298	244	204	174	130	45.1	0	0	0	0	0
40	11.6	26.4	49.3	92.1	133	172	211	248	284	320	357	393	428	426	363	298	249	172	77.9	0	0	0	0	0	0
Lubri- cation	I				II				III																

Remarks) 1. For HP rating of multiple strand, multiply the HP above by multiple strand factor shown in the table at right.  
 2. The operation in right part of the dotted line is not recommended.  
 3. The lubrication type is as follows. Type I : Manual & Drip feed, Type II : Oil bath and Disc, Type III : Pump  
 4. Dimensions & Ratings are subject to change without notice. Certified dimensions furnished upon request.

Number of Strands	2	3	4	5	6
Multiple Strand Factors	1.7	2.5	3.3	3.9	4.6

# OCM ANSI ROLLER CHAIN

Chain No. **160** Pitch • 2.000inch / 50.80mm

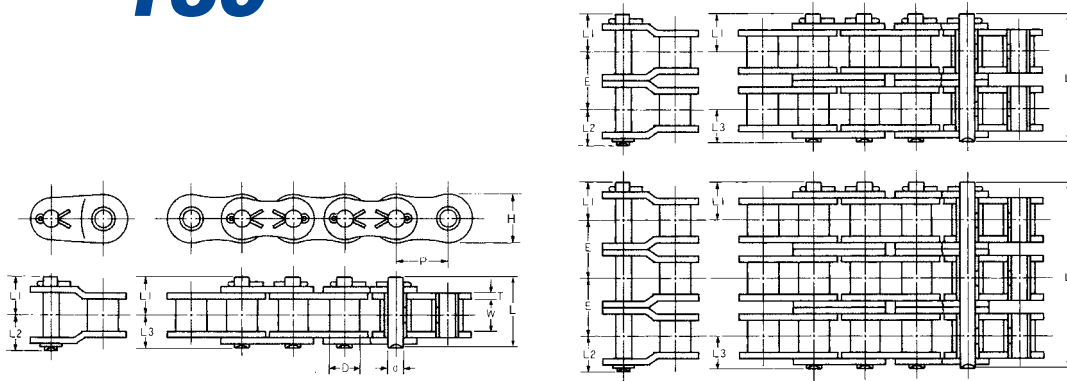

UNIT Upper:inch  
Beneath:mm

OCM Chain No.	ANSI No.	Pitch P	Roller Diam. D	Width between L.P. W	Link Plate		Pin Diam. d	Pin				Trans Pitch E	Average Tensile Strength Lb/kg	Max. Working Load Lb/kg	Approx Weight Lb/ft kg/m
					H	T		L	L1	L2	L3				
OCM160	160	2.000	1.126	1.250	1.899	0.252	0.563	2.723	1.454	1.370	1.269	2.305	57,980	12,128	6.603
		50.80	28.58	31.75	48.2	6.4	14.29	69.1	36.9	34.8	32.2	58.5	26,300	5,500	9.9
OCM160-2	160-2	2.000	1.126	1.250	1.899	0.252	0.563	5.027	1.454	1.370	1.269	2.305	115,960	20,617	13.073
		50.80	28.58	31.75	48.2	6.4	14.29	127.6	36.9	34.8	32.2	58.5	52,600	9,350	19.6
OCM160-3	160-3	2.000	1.126	1.250	1.899	0.252	0.563	7.332	1.454	1.370	1.269	2.305	173,940	30,319	19.543
		50.80	28.58	31.75	48.2	6.4	14.29	186.1	36.9	34.8	32.2	58.5	78,900	13,750	29.3
OCM160-4	160-4	2.000	1.126	1.250	1.899	0.252	0.563	9.637	1.454	1.370	1.269	2.305	231,920	40,021	25.946
		50.80	28.58	31.75	48.2	6.4	14.29	244.6	36.9	34.8	32.2	58.5	105,200	18,150	38.9
OCM160-5	160-5	2.000	1.126	1.250	1.899	0.252	0.563	11.942	1.454	1.370	1.269	2.305	289,900	47,297	32.416
		50.80	28.58	31.75	48.2	6.4	14.29	303.1	36.9	34.8	32.2	58.5	131,500	21,450	48.6
OCM160-6	160-6	2.000	1.126	1.250	1.899	0.252	0.563	14.247	1.454	1.370	1.269	2.305	347,880	55,787	38.886
		50.80	28.58	31.75	48.2	6.4	14.29	361.6	36.9	34.8	32.2	58.5	157,800	25,300	58.3

Note: Dimensions subject to change. Certified dimensions furnished upon request.

## HORSEPOWER RATINGS SINGLE STRAND ROLLER CHAIN

No. of Teeth Small Spkt.	REVOLUTIONS PER MINUTE-SMALL SPROCKET (rpm)																								
	10	25	50	100	150	200	250	300	350	400	450	500	550	600	650	700	750	800	850	900	1000	1100	1200	1300	1400
11	4.10	9.36	17.4	32.6	46.9	60.9	74.4	87.7	101	114	113	96.7	83.8	73.5	65.2	58.3	52.6	47.7	43.6	40.0	34.2	29.6	26.0	23.1	0
12	4.51	10.3	19.2	35.8	51.6	66.9	81.7	96.3	111	125	129	110.1	95.5	83.8	74.3	66.5	59.9	54.4	49.6	45.6	38.9	33.8	29.6	22.5	0
13	4.92	11.2	20.9	39.0	56.3	73.0	89.0	105	121	135	145	124.2	108	94.4	83.8	75.0	67.6	61.3	56.1	51.4	43.9	38.1	33.4	18.4	0
14	5.32	12.1	22.7	42.4	60.9	79.0	96.6	114	131	148	162	138	120	106	93.6	83.8	75.5	68.5	62.6	57.4	49.1	42.5	37.3	13.4	0
15	5.74	13.1	24.4	45.6	65.7	85.0	104	123	141	158	177	154	133	117	104	92.9	83.8	76.0	69.5	63.7	54.4	47.2	41.4	0	0
16	6.16	14.1	26.1	48.8	70.4	91.2	111	131	152	170	189	169	148	129	114	102	92.3	83.8	76.4	70.1	59.9	51.9	45.6	0	0
17	6.57	15.0	28.0	52.2	75.2	97.4	119	141	161	182	202	185	161	141	125	112	101	91.7	83.8	76.8	65.6	56.9	42.9	0	0
18	6.99	16.0	29.8	55.5	79.9	104	127	149	172	193	215	202	176	154	137	122	110	99.9	91.2	83.8	71.5	62.0	37.8	0	0
19	3.38	16.9	31.5	58.9	84.8	110	134	158	182	205	228	220	190	166	148	132	119	108	99.0	90.8	77.5	67.2	31.8	0	0
20	7.83	17.8	33.4	62.2	89.6	116	142	168	192	217	241	237	205	180	160	143	129	117	107	98.0	83.8	72.5	25.1	0	0
21	8.25	18.8	35.1	65.6	94.4	122	150	176	202	228	253	255	221	194	172	154	138	126	115	106	90.1	76.8	17.4	0	0
22	8.68	19.8	36.9	68.9	99.2	129	157	185	213	240	267	274	237	208	184	165	149	135	123	113	96.7	72.0	0	0	0
23	9.11	20.8	38.8	72.3	104	135	165	194	224	252	280	292	253	223	197	177	160	145	132	121	103	66.4	0	0	0
24	9.53	21.7	40.6	75.8	109	141	173	204	233	264	294	311	270	237	211	188	169	154	141	129	110	59.9	0	0	0
25	9.96	22.7	42.4	79.1	114	148	181	213	244	276	307	323	287	252	224	200	180	164	149	137	117	52.7	0	0	0
26	10.4	23.7	44.3	82.6	119	154	188	223	255	287	319	331	304	267	237	212	192	173	158	145	116	44.7	0	0	0
28	11.3	25.7	47.9	89.4	129	166	204	240	276	311	346	347	337	299	264	237	213	194	177	162	105	26.3	0	0	0
30	12.1	27.6	51.6	96.4	139	180	220	259	298	335	367	361	349	331	294	263	237	215	196	168	91.2	0	0	0	0
32	13.0	29.6	55.4	103	149	193	236	278	319	359	382	374	361	342	320	290	261	233	197	160	74.6	0	0	0	0
35	14.3	32.7	61.0	114	164	212	260	306	351	397	401	390	373	351	326	296	263	225	185	141	44.5	0	0	0	0
40	16.5	37.8	70.4	132	189	245	300	354	406	437	426	410	388	359	327	288	247	201	150	97.2	0	0	0	0	0
Lubri-cation	I	II		III																					

Remarks) 1. For HP rating of multiple strand, multiply the HP above by multiple strand factor shown in the table at right.  
2. The operation in right part of the dotted line is not recommended.  
3. The lubrication type is as follows. Type I: Manual & Drip feed, Type II: Oil bath and Disc, Type III: Pump  
4. Dimensions & Ratings are subject to change without notice. Certified dimensions furnished upon request.

Number of Strands	2	3	4	5	6
Multiple Strand Factors	1.7	2.5	3.3	3.9	4.6

# OCM ANSI ROLLER CHAIN

Chain No. **180** Pitch • 2.250inch / 57.15mm

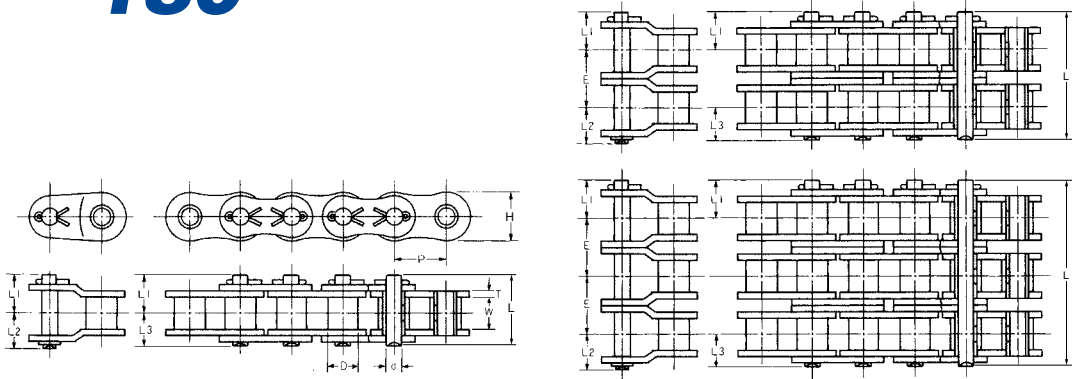

UNIT Upper:inch  
Beneath:mm

OCM Chain No.	Pitch P	Roller Diam. D	Width between L.P. W	Link Plate		Pin Diam. d	Pin				Trans Pitch E	Average Tensile Strength	Max. Working Load	Approx Weight
				H	T		L	L1	L2	L3				
OCM180	2.250	1.407	1.407	2.135	0.284	0.688	3.120	1.675	1.543	1.446	2.593	73,630	14,112	8.978
	57.15	35.71	35.7	54.2	7.2	17.45	79.2	42.5	39.2	36.7	65.8	33,400	6,400	13.46
OCM180-2	2.250	1.407	1.407	2.135	0.284	0.688	5.713	1.675	1.543	1.446	2.593	147,260	23,990	17.669
	57.15	35.71	35.7	54.2	7.2	17.45	145.0	42.5	39.2	36.7	65.8	66,800	10,880	26.49
OCM180-3	2.250	1.407	1.407	2.135	0.284	0.688	8.306	1.675	1.543	1.446	2.593	220,900	35,280	25.526
	57.15	35.71	35.7	54.2	7.2	17.45	210.8	42.5	39.2	36.7	65.8	100,200	16,000	38.27
OCM180-4	2.250	1.407	1.407	2.135	0.284	0.688	10.898	1.675	1.543	1.446	2.593	294,500	46,570	33.964
	57.15	35.71	35.7	54.2	7.2	17.45	276.6	42.5	39.2	36.7	65.8	133,600	21,120	50.92
OCM180-5	2.250	1.407	1.407	2.135	0.284	0.688	13.491	1.675	1.543	1.446	2.593	368,170	55,037	42.421
	57.15	35.71	35.7	54.2	7.2	17.45	342.4	42.5	39.2	36.7	65.8	167,000	24,960	63.60
OCM180-6	2.250	1.407	1.407	2.135	0.284	0.688	16.083	1.675	1.543	1.446	2.593	441,800	64,915	50.825
	57.15	35.71	35.7	54.2	7.2	17.45	408.2	42.5	39.2	36.7	65.8	200,400	29,440	76.20

Note: Dimensions subject to change. Certified dimensions furnished upon request.

## HORSEPOWER RATINGS SINGLE STRAND ROLLER CHAIN

No. of Teeth Small Splt.	REVOLUTIONS PER MINUTE-SMALL SPROCKET (rpm)																							
	10	25	50	100	150	200	250	300	350	400	450	500	550	600	650	700	750	800	850	900	950	1000	1050	1100
11	5.38	12.3	22.9	42.8	61.6	79.8	97.5	115	132	149	124	106	92.0	80.7	71.6	64.1	57.8	52.4	47.9	44.0	40.5	37.5	24.5	5.87
12	5.91	13.5	25.2	46.9	67.6	87.7	107	126	145	164	142	121	105	92.0	81.7	73.1	65.8	59.8	54.6	50.2	46.1	41.4	21.7	0
13	6.45	14.8	27.5	51.2	73.8	95.6	117	138	158	178	160	137	118	104	92.0	86.4	74.3	67.5	61.6	56.5	52.0	39.7	18.2	0
14	6.99	16.0	29.8	55.5	79.9	104	127	149	172	193	178	153	132	116	103	92.0	83.0	75.4	68.8	63.2	58.2	37.1	13.7	0
15	7.52	17.2	32.0	59.8	86.1	112	137	161	185	208	198	169	146	129	114	102	92.0	83.5	76.3	70.0	57.9	33.9	0	0
16	8.07	18.4	34.3	64.1	92.3	120	146	172	198	219	216	186	161	142	126	112	101	92.0	84.1	77.1	55.8	29.8	0	0
17	8.61	19.7	36.6	68.4	98.6	128	156	184	212	229	227	204	177	156	138	123	111	101	92.0	79.3	52.8	24.9	0	0
18	9.16	20.9	39.0	72.8	105	135	166	196	225	240	237	223	193	169	150	134	121	110	100	77.5	49.2	19.2	0	0
19	9.71	22.1	41.3	77.1	111	143	176	208	239	251	247	239	209	184	162	145	131	119	103	75.0	44.8	0	0	0
20	10.3	23.5	43.7	81.5	117	152	186	219	252	261	256	247	225	198	176	157	142	129	102	71.9	39.6	0	0	0
21	10.8	24.7	46.0	86.0	124	161	196	231	266	271	266	256	243	213	189	169	153	130	100	67.9	33.7	0	0	0
22	11.4	26.0	48.4	90.4	130	169	207	243	279	280	274	263	249	228	202	181	158	129	97.5	63.3	27.0	0	0	0
23	11.9	27.2	50.8	94.8	137	177	216	255	278	290	282	271	255	236	213	188	160	128	94.1	57.9	0	0	0	0
24	12.5	28.6	53.2	99.2	143	185	227	267	300	298	290	278	261	240	217	189	160	126	90.1	51.9	0	0	0	0
25	13.1	29.8	55.7	104	149	193	237	279	310	306	298	284	267	244	219	190	158	123	85.4	45.1	0	0	0	0
26	13.7	31.1	58.1	108	156	202	247	291	318	314	304	291	271	248	221	190	157	120	80.1	37.5	0	0	0	0
28	14.8	33.7	62.4	117	169	219	267	315	334	330	318	302	280	253	224	189	152	111	67.3	0	0	0	0	0
30	16.0	36.3	67.7	126	182	236	288	339	350	343	330	311	287	257	224	186	145	100	51.8	0	0	0	0	0
32	17.0	38.9	72.5	135	196	253	308	365	365	357	341	319	292	260	223	181	135	86.5	33.7	0	0	0	0	0
35	18.8	42.9	79.9	149	215	279	341	386	384	373	354	329	296	259	216	169	117.1	61.1	0	0	0	0	0	0
40	21.7	49.5	92.4	173	248	322	393	418	412	394	369	335	295	248	196	138	74.3	0	0	0	0	0	0	0
Lubri-cation	I		II		III																			

Remarks) 1. For HP rating of multiple strand, multiply the HP above by multiple strand factor shown in the table at right.  
 2. The operation in right part of the dotted line is not recommended.  
 3. The lubrication type is as follows. Type I : Manual & Drip feed, Type II : Oil bath and Disc, Type III : Pump  
 4. Dimensions & Ratings are subject to change without notice. Certified dimensions furnished upon request.

Number of Strands	2	3	4	5	6
Multiple Strand Factors	1.7	2.5	3.3	3.9	4.6

# OCM ANSI ROLLER CHAIN

Chain No. **200** Pitch • 2.500inch / 63.50mm

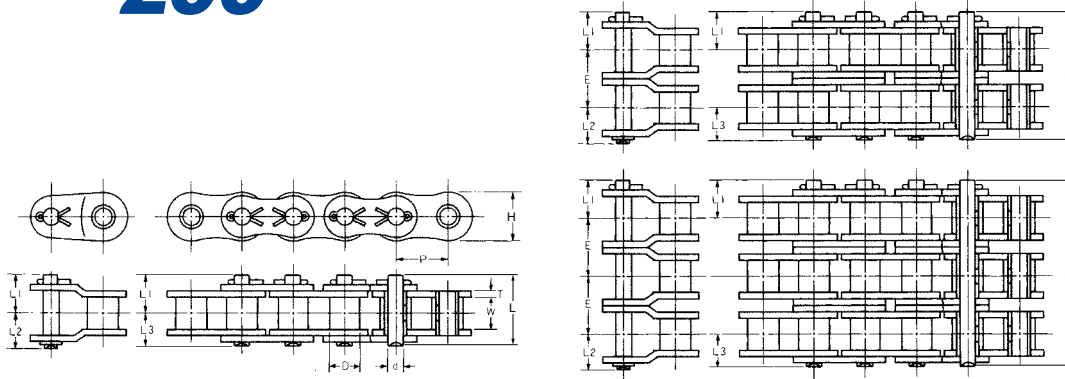

UNIT Upper:inch  
Beneath:mm

OCM Chain No.	ANSI No.	Pitch P	Roller Diam. D	Width between L.P. W	Link Plate		Pin Diam. d	Pin				Trans Pitch E	Average Tensile Strength Lb/kg	Max. Working Load Lb/kg	Approx Weight Lb/ft kg/m
					H	T		L	L1	L2	L3				
OCM200	200	2.500	1.563	1.500	2.368	0.315	0.782	3.361	1.785	1.670	1.576	2.821	95,000	15,876	11.066
		63.50	39.68	38.1	60.1	8.0	19.85	85.3	45.3	42.4	40.0	71.6	43,100	7,200	16.5
OCM200-2	200-2	2.500	1.563	1.500	2.368	0.315	0.782	6.182	1.785	1.670	1.576	2.821	190,000	26,989	21.678
		63.50	39.68	38.1	60.1	8.0	19.85	156.9	45.3	42.4	40.0	71.6	86,200	12,240	32.5
OCM200-3	200-3	2.500	1.563	1.500	2.368	0.315	0.782	9.003	1.785	1.670	1.576	2.821	285,050	39,690	32.416
		63.50	39.68	38.1	60.1	8.0	19.85	228.5	45.3	42.4	40.0	71.6	129,300	18,000	48.6
OCM200-4	200-4	2.500	1.563	1.500	2.368	0.315	0.782	11.824	1.785	1.670	1.576	2.821	380,070	52,391	43.088
		63.50	39.68	38.1	60.1	8.0	19.85	300.1	45.3	42.4	40.0	71.6	172,400	23,760	64.6
OCM200-5	200-5	2.500	1.563	1.500	2.368	0.315	0.782	14.645	1.785	1.670	1.576	2.821	475,090	61,916	53.760
		63.50	39.68	38.1	60.1	8.0	19.85	371.7	45.3	42.4	40.0	71.6	215,500	28,080	80.6
OCM200-6	200-6	2.500	1.563	1.500	2.368	0.315	0.782	17.466	1.785	1.670	1.576	2.821	570,100	73,030	64.432
		63.50	39.68	38.1	60.1	8.0	19.85	443.3	45.3	42.4	40.0	71.6	258,600	33,120	96.6

Note: Dimensions subject to change. Certified dimensions furnished upon request

## HORSEPOWER RATINGS SINGLE STRAND ROLLER CHAIN

No. of Teeth Small Spkt.	REVOLUTIONS PER MINUTE-SMALL SPROCKET (rpm)																								
	10	15	20	30	40	50	60	80	100	150	200	250	300	350	400	450	550	600	650	700	750	800	850	900	950
11	6.72	9.68	12.6	18.1	23.5	28.6	33.7	43.7	53.4	77.0	99.6	122	143	149	148	135	100	87.8	77.9	69.7	62.9	57.1	38.8	19.0	0
12	7.39	10.6	13.8	19.8	25.7	31.4	37.0	48.0	58.6	84.5	109	134	158	161	160	154	114	100	88.8	79.4	71.6	58.5	38.0	16.1	0
13	8.05	11.6	15.0	21.6	28.0	34.3	40.4	52.3	64.0	92.1	119	146	172	173	170	165	129	113	100	89.6	79.8	58.9	36.5	12.5	0
14	8.73	12.6	16.2	23.5	30.4	37.1	43.7	56.7	69.3	99.8	129	158	182	184	181	174	143	126	112	100	81.4	58.6	34.2	0	0
15	9.40	13.5	17.6	25.2	32.7	40.0	47.2	61.0	74.7	108	139	170	193	194	190	184	160	139	124	105	82.3	57.7	31.1	0	0
16	10.1	14.5	18.8	27.1	35.1	42.9	50.6	65.4	80.1	115	149	182	205	205	201	193	168	150	130	107	82.7	56.1	27.5	0	0
17	10.8	15.6	20.1	29.0	37.4	45.9	53.9	69.9	85.4	123	160	194	215	216	211	202	173	154	133	109	82.5	53.8	22.9	0	0
18	11.4	16.5	21.3	30.7	39.8	48.7	57.4	74.4	90.9	131	169	208	225	225	220	211	180	160	135	110	81.7	50.8	17.8	0	0
19	12.1	17.4	22.7	32.6	42.2	51.6	60.9	78.9	96.4	139	180	220	236	235	229	219	185	164	138	110	80.1	47.2	0	0	0
20	12.8	18.5	23.9	34.5	44.7	54.6	64.4	83.3	102	146	190	232	245	244	237	227	190	166	139	110	77.9	42.8	0	0	0
21	13.5	19.4	25.2	36.3	47.1	57.5	67.9	87.8	107	154	200	245	255	253	245	233	194	170	141	110	75.1	37.8	0	0	0
22	14.2	20.5	26.6	38.2	49.5	60.5	71.3	92.4	113	162	211	257	264	263	253	240	198	172	142	108	71.6	32.0	0	0	0
23	14.9	21.5	27.9	40.1	51.9	63.4	74.8	97.0	118	178	221	268	274	271	261	247	202	174	142	106	67.5	25.7	0	0	0
24	15.6	22.5	29.1	42.0	54.3	66.5	78.3	102	124	184	232	278	283	279	268	252	205	176	141	104	62.8	18.6	0	0	0
25	16.4	23.5	30.4	43.9	56.9	69.5	81.8	106	130	186	241	287	291	287	276	259	208	177	141	101	57.4	0	0	0	0
26	17.0	24.5	31.8	45.7	59.3	72.4	85.4	111	135	194	252	295	299	295	283	264	211	177	139	97.0	51.4	0	0	0	0
28	18.5	26.6	34.5	49.6	64.2	78.4	92.5	120	146	211	274	312	315	308	295	274	213	176	134	87.7	37.4	0	0	0	0
30	19.8	28.6	37.0	53.4	69.2	84.6	99.6	129	158	228	295	329	330	322	306	282	215	173	127	76.0	0	0	0	0	0
32	21.3	30.7	39.7	57.3	74.2	90.7	107	138	169	244	315	343	343	334	315	288	215	169	118	62.0	0	0	0	0	0
35	23.5	33.8	43.9	63.0	81.7	99.9	118	153	186	268	347	365	365	362	349	326	295	209	157	99.5	36.5	0	0	0	0
40	27.1	39.0	50.6	72.8	94.4	115	135	176	216	310	386	396	396	389	362	339	299	193	128.7	58.3	0	0	0	0	0

Lubrication	I	II	III
-------------	---	----	-----

Remarks) 1. For HP rating of multiple strand, multiply the HP above by multiple strand factor shown in the table at right.  
 2. The operation in right part of the dotted line is not recommended.  
 3. The lubrication type is as follows. Type I : Manual & Drip feed, Type II : Oil bath and Disc, Type III : Pump  
 4. Dimensions & Ratings are subject to change without notice. Certified dimensions furnished upon request.

Number of Strands	2	3	4	5	6
Multiple Strand Factors	1.7	2.5	3.3	3.9	4.6

# OCM ANSI ROLLER CHAIN

Chain No. **240** Pitch • 3.000inch / 76.20mm

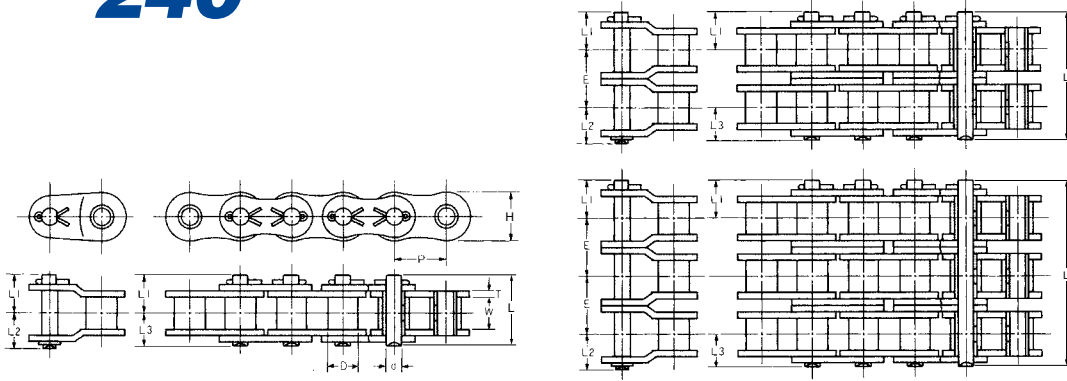

UNIT Upper:inch  
Beneath:mm

OCM Chain No.	ANSI No.	Pitch P	Roller Diam. D	Width between L.P. W		Link Plate		Pin Diam. d	Pin				Trans Pitch E	Average Tensile Strength	Max. Working Load	Approx Weight
				H	T	L	L1		L2	L3	Lb/kg	Lb/kg				
OCM240	240	3.000 76.20	1.877 47.63	1.890 48.0	2.850 72.4	0.374 9.5	0.938 23.80	4.125 104.7	2.199 55.8	2.055 52.2	1.927 48.9	3.459 87.8	149,940 68,000	21,830 9,900	16.542 24.8	
OCM240-2	240-2	3.000 76.20	1.877 47.63	1.890 48.0	2.850 72.4	0.374 9.5	0.938 23.80	7.585 192.5	2.199 55.8	2.055 52.2	1.927 48.9	3.459 87.8	299,880 136,000	37,110 16,830	32.683 49.0	
OCM240-3	240-3	3.000 76.20	1.877 47.63	1.890 48.0	2.850 72.4	0.374 9.5	0.938 23.80	11.044 280.3	2.199 55.8	2.055 52.2	1.927 48.9	3.459 87.8	449,820 204,000	54,574 24,750	48.758 73.1	
OCM240-4	240-4	3.000 76.20	1.877 47.63	1.890 48.0	2.850 72.4	0.374 9.5	0.938 23.80	14.503 368.1	2.199 55.8	2.055 52.2	1.927 48.9	3.459 87.8	599,760 272,000	72,037 32,670	64.832 97.2	
OCM240-5	240-5	3.000 76.20	1.877 47.63	1.890 48.0	2.850 72.4	0.374 9.5	0.938 23.80	17.962 455.9	2.199 55.8	2.055 52.2	1.927 48.9	3.459 87.8	749,700 340,000	85,135 38,610	80.907 121.3	
OCM240-6	240-6	3.000 76.20	1.877 47.63	1.890 48.0	2.850 72.4	0.374 9.5	0.938 23.80	21.422 543.7	2.199 55.8	2.055 52.2	1.927 48.9	3.459 87.8	899,640 408,000	100,416 45,540	96.848 145.2	

Note: Dimensions subject to change. Certified dimensions furnished upon request.

## HORSEPOWER RATINGS SINGLE STRAND ROLLER CHAIN

No. of Teeth Small Spkt.	REVOLUTIONS PER MINUTE-SMALL SPROCKET (rpm)																											
	5	10	15	20	25	30	40	50	60	80	100	125	150	175	200	250	300	350	400	450	500	550	600	650	700			
11	5.95	11.1	16.0	20.7	25.3	29.8	38.6	47.2	55.7	72.1	88.2	108	118	123	127	129	127	120	109	94.7	77.8	58.1	36.1	11.9	0			
12	6.53	12.2	17.6	22.8	27.8	32.7	42.5	51.9	61.1	79.3	96.8	118	128	133	137	139	137	128	116	101	81.8	60.1	35.8	9.16	0			
13	7.12	13.3	19.2	24.8	30.3	35.7	46.3	56.6	66.6	86.4	106	128	137	143	148	150	146	137	124	106	85.4	61.6	35.0	5.74	0			
14	7.72	14.3	20.8	26.8	32.9	38.8	50.2	61.3	72.3	93.6	114	137	146	153	157	160	156	145	130	111	88.5	62.5	33.5	0	0			
15	8.31	15.6	22.4	29.0	35.4	41.7	54.0	66.1	77.8	101	123	146	156	162	168	169	164	153	137	116	91.2	62.9	31.4	0	0			
16	8.92	16.6	24.0	31.1	38.0	44.7	57.9	70.8	83.4	108	132	156	165	172	177	178	173	160	142	120	93.3	62.8	28.8	0	0			
17	9.52	17.7	25.6	33.1	40.5	47.7	61.8	75.6	89.0	115	141	164	174	181	186	188	181	168	148	124	94.9	62.1	25.5	0	0			
18	10.1	18.9	27.2	35.3	43.0	50.8	65.8	80.5	94.8	123	150	172	184	190	194	196	189	174	153	127	96.0	60.7	21.7	0	0			
19	10.7	20.0	28.8	37.4	45.7	53.8	69.7	85.3	100	130	160	181	192	200	204	205	196	180	158	130	96.7	59.0	17.3	0	0			
20	11.3	21.2	30.4	39.6	48.3	56.9	73.8	90.1	106	138	168	189	201	208	213	213	204	186	162	132	96.8	56.7	0	0	0			
21	12.0	22.3	32.2	41.7	51.0	59.9	77.8	94.9	112	145	177	197	209	217	221	221	211	192	166	134	96.4	53.8	0	0	0			
22	12.6	23.5	33.8	43.9	53.5	63.0	81.7	99.9	118	153	186	205	217	225	229	229	217	197	170	135	95.6	50.4	0	0	0			
23	13.2	24.7	35.4	46.0	56.2	66.2	85.7	105	124	160	194	213	225	233	237	236	224	202	173	137	94.3	46.4	0	0	0			
24	13.8	25.7	37.1	48.1	58.9	69.3	89.7	110	129	168	202	221	233	241	245	244	231	207	176	137	92.4	42.0	0	0	0			
25	14.5	27.0	38.8	50.3	61.4	72.4	93.9	115	135	176	209	228	241	249	253	251	236	212	178	137	90.1	36.9	0	0	0			
26	15.0	28.2	40.5	52.4	64.1	75.5	97.9	120	141	182	216	236	249	257	261	257	241	216	180	137	87.3	31.2	0	0	0			
28	16.4	30.4	43.9	56.9	69.5	81.8	106	130	153	198	231	251	264	272	276	271	252	223	182	135	80.2	0	0	0	0			
30	17.6	32.9	47.2	61.1	74.8	88.2	114	139	165	213	244	264	279	287	290	283	261	228	184	131	71.1	0	0	0	0			
32	18.9	35.1	50.7	65.6	80.2	94.5	122	150	177	228	256	279	292	300	303	294	270	232	184	126	59.9	0	0	0	0			
35	20.8	38.8	55.8	72.3	88.4	104	135	165	194	249	275	298	312	319	320	308	279	235	180	114	39.6	0	0	0	0			
40	24.0	44.8	64.5	83.5	102	120	156	190	224	278	304	329	342	347	346	327	288	235	166	86.2	0	0	0	0	0			
Lubri-cation	I							II							III													

Remarks) 1. For HP rating of multiple strand, multiply the HP above by multiple strand factor shown in the table at right.  
 2. The operation in right part of the dotted line is not recommended.  
 3. The lubrication type is as follows. Type I : Manual & Drip feed, Type II : Oil bath and Disc, Type III : Pump  
 4. Dimensions & Ratings are subject to change without notice. Certified dimensions furnished upon request.

Number of Strands	2	3	4	5	6
Multiple Strand Factors	1.7	2.5	3.3	3.9	4.6

# ANSI ROLLER CHAIN HEAVY SERIES

Heavy Series differs from standard roller chain in link plate thickness. All the others are identical. There is no increase in tensile strength, but the thick link plate helps withstand abnormal shock loads.

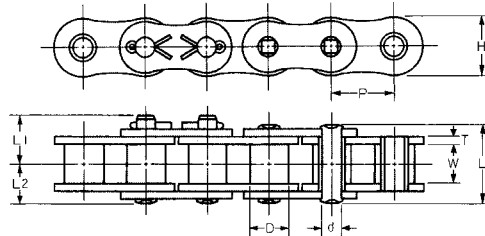

UNIT Upper:inch  
Beneath:mm

OCM Chain No.	ANSI No.	Pitch	Roller Diam.	Width between L.P.	Link Plate		Pin Diam.	Pin			Average Tensile Strength	Max. Working Load	Approx Weight
		P	D	W	H	T	d	L	L1	L2	Lb/kg	Lb/kg	Lb/ft kg/m
OCM 35H	(2H33B)	0.375	★ 0.200	0.189	0.358	0.079	0.141	0.583	-	-	3,902	728	0.356
		9.525	★ 5.08	4.80	9.10	2.00	3.58	14.80	-	-	1,770	330	0.53
OCM 40H	(2H45E)	0.500	0.313	0.313	■ 0.472	0.079	0.156	0.689	-	-	5,181	1,235	0.558
		12.70	7.94	7.95	■ 12.00	2.00	3.96	17.50	-	-	2,350	560	0.83
OCM 50H	(2H53)	0.625	0.400	0.376	0.591	0.094	0.200	0.862	-	-	8,818	1,543	0.806
		15.875	10.16	9.55	15.00	2.40	5.08	21.90	-	-	4,000	700	1.20
OCM 60H	60H	0.750	0.469	0.500	0.709	0.126	0.234	1.130	0.650	0.563	9,921	2,425	1.263
		19.05	11.91	12.70	18.00	3.20	5.95	28.70	16.50	14.30	4,500	1,100	1.88
OCM 80H	80H	1.000	0.625	0.626	0.949	0.157	0.313	1.413	0.839	0.709	17,637	3,968	2.083
		25.40	15.88	15.90	24.10	4.00	7.94	35.90	21.30	18.00	8,000	1,800	3.10
OCM 100H	100H	1.250	0.750	0.754	1.185	0.189	0.375	1.697	0.992	0.850	26,455	6,173	3.091
		31.75	19.05	19.15	30.10	4.80	9.53	43.10	25.20	21.60	12,000	2,800	4.60
OCM 120H	120H	1.500	0.875	1.006	1.425	0.220	0.437	2.110	1.185	1.055	37,038	7,937	4.435
		38.10	22.23	25.55	36.20	5.60	11.11	53.60	30.10	26.80	16,800	3,600	6.60
OCM 140H	140H	1.750	1.000	1.000	1.661	0.252	0.500	2.260	1.315	1.130	48,722	10,362	5.644
		44.45	25.40	25.40	42.20	6.40	12.70	57.40	33.40	28.70	22,100	4,700	8.40
OCM 160H	160H	2.000	1.125	1.250	1.898	0.283	0.563	2.673	1.520	1.339	60,186	12,566	7.19
		50.80	28.58	31.75	48.20	7.20	14.29	67.90	38.60	34.00	27,300	5,700	10.7
OCM 200H	200H	2.500	1.562	1.500	2.366	0.374	0.781	3.398	1.909	1.701	103,617	16,314	12.229
		63.50	39.68	38.10	60.10	9.50	19.84	86.30	48.50	43.20	47,000	7,400	18.2

★ indicates bush diameter ■ indicates straight link plate • Chain number shown in ( ) is not ANSI No.



# DOUBLE PITCH ROLLER CHAIN

This chain is more economical than standard roller chain and well suited for applications where shaft centers are long. Stainless steel chain is available.

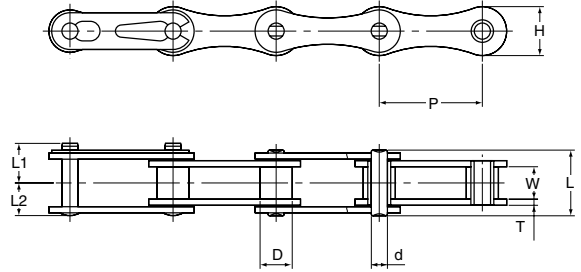

UNIT Upper:inch  
Beneath:mm

OCM Chain No.	ANSI No.	Pitch	Roller Diam.	Width between L.P.	Link Plate		Pin Diam.	Pin			Average Tensile Strength	Approx Weight
		P	D	W	H	T	d	L	L1	L2	Lb/kg	Lb/ft kg/m
OCM2040	2040	1.000	0.312	0.312	0.472	0.060	0.156	0.634	0.382	0.319	3,784	0.27
		25.40	7.94	7.95	12.0	1.5	3.96	16.1	9.7	8.1	1,950	0.41
OCM2050	2050	1.250	0.400	0.376	0.591	0.080	0.200	0.799	0.476	0.409	6,380	0.45
		31.75	10.16	9.55	15.0	2.0	5.08	20.3	12.1	10.4	3,200	0.67
OCM2060	2060	1.500	0.469	0.500	0.677	0.094	0.234	1.000	0.579	0.500	8,910	0.63
		38.10	11.91	12.70	17.2	2.4	5.95	25.4	14.7	12.7	4,450	0.94
OCM2080	2080	2.000	0.625	0.626	0.945	0.125	0.312	1.287	0.760	0.647	16,060	1.139
		50.80	15.88	15.90	24.0	3.2	7.94	32.7	19.3	16.3	7,500	1.70

1. Spring clip type is standard for connecting links of 2040 through 2060 and cotter for 2080 and above.  
Note: Dimensions subject to change. Certified dimensions furnished upon request.

# OCM SELUBE CHAIN

**OCM SELUBE chains provide excellent wear life without lubrication as much as 8 to 30 times better than standard roller chain.**

SELUBE chain is made up of sintered metal bushings impregnated with high quality oil and plated pins. As SELUBE chain does not require lubrication, it is suitable for applications where lubrication is not possible or practical. All major dimensions are the same as standard roller chain.

SELUBE chain can immediately replace standard ANSI roller chain. The operating temperature should be within a range of -10°C (14°F) to 150°C (300°F). The chain operating speed should be kept below 150m (490feet) per minute.

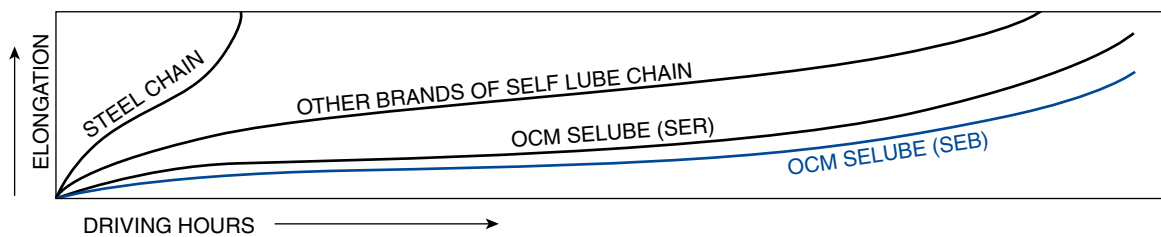

SEB type SELUBE chain has the same maximum allowable load guidelines as standard roller chain. This chain has shouldered sintered bushings with heavy link plates. As compared with SER type, the bushings of SEB are larger and more oil impregnated. SEB type can last longer than SER without lubrication. This chain can operate on standard sprockets.

SEB

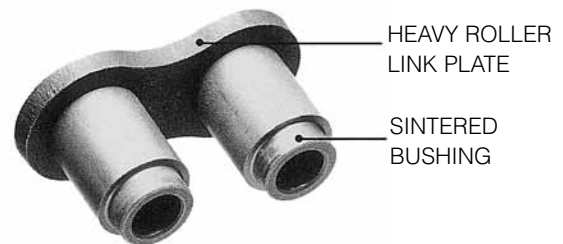

SER type SELUBE chain has the same maximum allowable load guidelines as standard roller chain. This chain has straight bushings with rollers and heavy roller link plates.

SER type chain offers smooth engagement with the sprocket. This chain can operate on standard sprockets.

SER

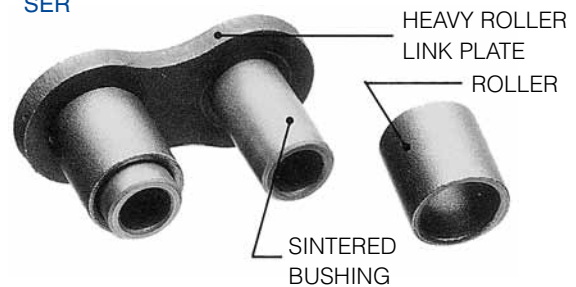

SELUBE small conveyor chain has straight sintered bushings impregnated with high quality oil and strong rollers.

This chain can replace standard conveyor chain and operate on standard sprockets.

The strength of SELUBE small conveyor is lower than that of SER, SEB and standard steel chain.



# SELUBE CHAIN

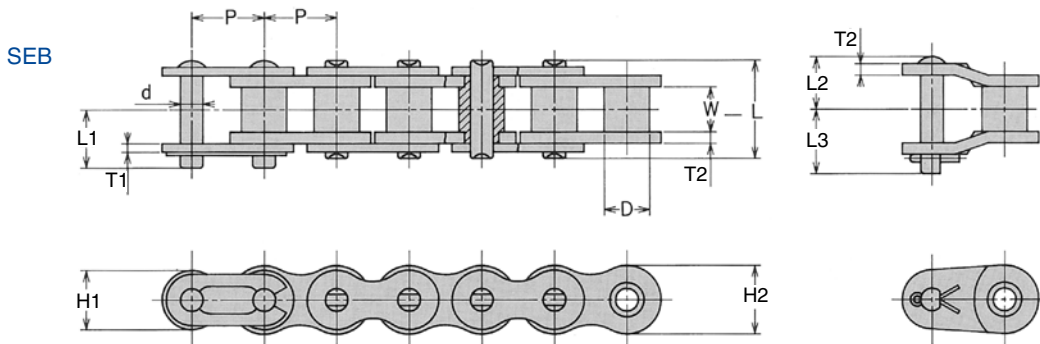

40J-SEB-60J-SEB

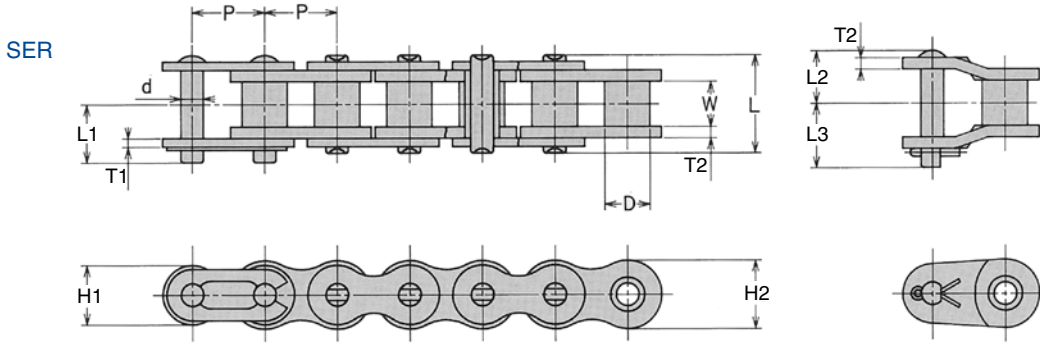

40J-SER~120J-SER

UNIT Upper:inch  
Beneath:mm

OCM Chain No.	Pitch P	Roller Diam. D	Width between L.P. W	Link Plate				Pin Diam. d	Pin				Average Tensile Strength Lb/kgf	Max Allowable Load Lb/kgf	Approx Weight Lb/ft kg/m
				H1	H2	T1	T2		L	L1	L2	L3			
40J-SER	0.500	0.312	0.311	0.409	0.472	0.059	0.079	0.156	0.681	0.402	0.362	0.445	4,299	860	0.48
40J-SEB	12.70	7.92	7.90	10.40	12.00	1.50	2.00	3.96	17.30	10.20	9.20	11.30	1,950	390	0.72
50J-SER	0.625	0.400	0.374	0.512	0.591	0.080	0.094	0.200	0.835	0.496	0.429	0.520	7,165	1,389	0.77
50J-SEB	15.875	10.16	9.50	13.00	15.00	2.00	2.40	5.08	21.20	12.60	10.90	13.20	3,250	630	1.14
60J-SER	0.75	0.469	0.500	0.602	0.709	0.094	0.126	0.234	1.079	0.61	0.571	0.669	9,921	2,094	1.17
60J-SEB	19.05	11.91	12.70	15.30	18.00	2.40	3.20	5.95	27.40	15.50	14.50	17.00	4,500	950	1.74
80J-SER	1.000	0.625	0.626	0.819	0.949	0.126	0.157	0.313	1.354	0.776	0.768	0.839	17,637	3,638	2.02
	25.40	15.88	15.90	20.80	24.10	3.20	4.00	7.94	34.40	19.70	19.50	21.30	8,000	1,650	3.00
100J-SER	1.250	0.750	0.754	1.024	1.185	0.157	0.189	0.375	1.634	0.957	0.913	0.992	26,455	5,512	2.96
	31.75	19.05	19.15	26.00	30.10	4.00	4.80	9.53	41.50	24.30	23.20	25.20	12,000	2,500	4.40
120J-SER	1.500	0.875	1.006	1.228	1.425	0.189	0.22	0.437	2.035	1.15	1.138	1.185	37,479	7,275	4.30
	38.10	22.23	25.55	31.20	36.20	4.80	5.60	11.11	51.70	29.20	28.90	30.10	17,000	3,300	6.40

# SELUBE SMALL CONVEYOR CHAIN

## SELUBE DOUBLE PITCH ROLLER CHAIN

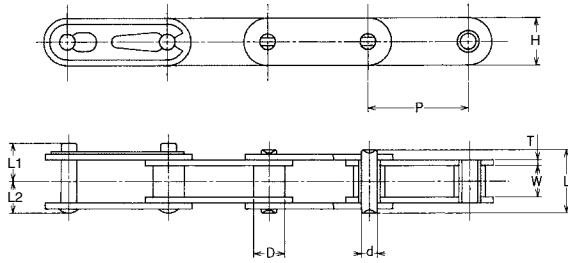

SMALL ROLLER

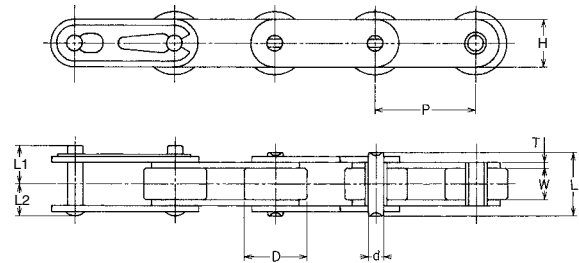

LARGE ROLLER

UNIT Upper:inch  
Beneath:mm

OCM ChainNo.	Pitch	Roller Diam.	Width between L.P.	Link Plate		Pin Diam.	Pin			Average Breaking Load	Max. Allowable Load	Approx Weight
	P	D	W	H	T	d	L	L1	L2	Lb/kN{kgf}	Lb/kN{kgf}	Lb/ft kg/m
OCM C2040-SER	1.000	0.312/ 7.94	0.312	0.472	0.059	0.156	0.634	0.382	0.319	3,520	616	0.34/0.51
OCM C2042-SER	25.40	0.625/15.88	7.95	12.0	1.5	3.96	16.1	9.7	8.1	15.69{1,600}	2.75{ 280}	0.58/0.87
OCM C2050-SER	1.250	0.400/10.16	0.376	0.591	0.079	0.200	0.799	0.476	0.409	5,720	1,012	0.58/0.87
OCM C2052-SER	31.75	0.750/19.05	9.55	15.0	2.0	5.08	20.3	12.1	10.4	25.49{2,600}	4.51{ 460}	0.90/1.35
OCM C2060H-SER	1.500	0.469/11.91	0.500	0.677	0.126	0.234	1.130	0.650	0.563	8,360	1,408	1.01/1.51
OCM C2062H-SER	38.10	0.875/22.23	12.70	17.2	3.2	5.95	28.7	16.5	14.3	37.26{3,800}	6.27{ 640}	1.47/2.19
OCM C2080H-SER	2.000	0.625/15.88	0.626	0.945	0.157	0.312	1.413	0.830	0.709	14,300	2,354	1.77/2.66
OCM C2082H-SER	50.80	1.125/28.58	15.90	24.0	4.0	7.94	35.9	21.3	18.0	63.73{6,500}	10.49{1,070}	2.45/3.68

# SELUBE SMALL CONVEYOR CHAIN

## SELUBE ROLLER CHAIN WITH ATTACHMENT

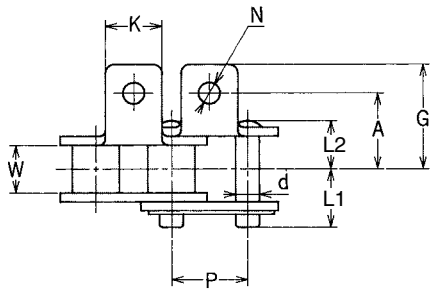
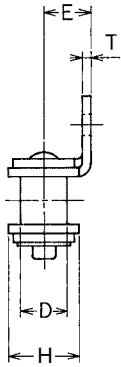

TYPE A-1

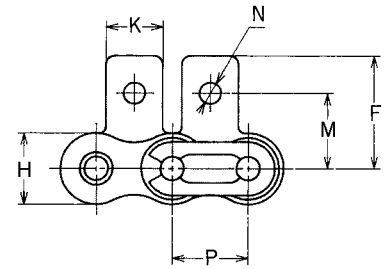
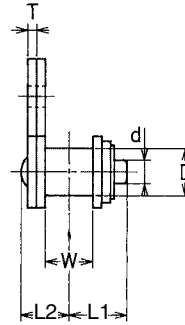

TYPE SA-1

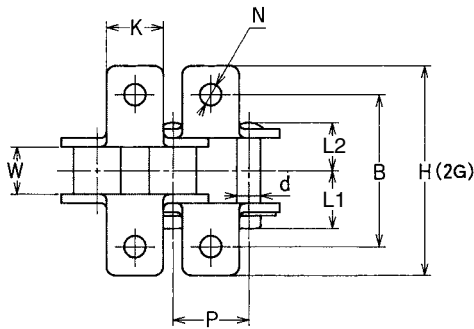
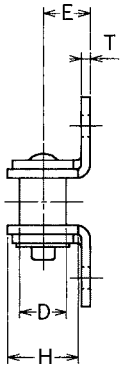

TYPE K-1

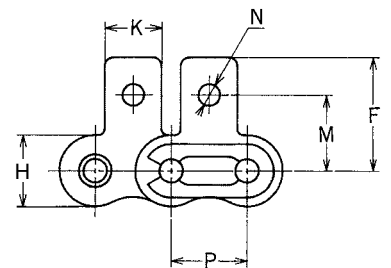
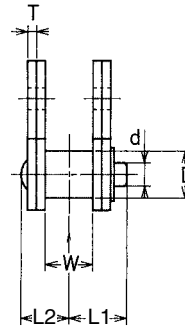

TYPE SK-1

UNIT Upper:inch  
Beneath:mm

OCM Chain No.	Pitch P	Roller Diam. D	Width between L.P.		Link Plate		Pin Diam. d	Pin		Average Breaking Load Lb/kN{kgf}	Max. Allowable Load Lb/kN{kgf}	Approx Weight Without Attachment Lb/ft·kg/m
			W	H	T	L1		L2				
OCM 40-SER	0.500 12.70	0.312 7.94	0.313 7.95	0.472 12.0	0.059 1.5	0.155 3.96	0.381 9.7	0.318 8.1	3,520 {1,600}	616 {280}	0.443 0.66	
OCM 50-SER	0.625 15.875	0.400 10.16	0.375 9.55	0.590 15.0	0.078 2.0	0.200 5.08	0.476 12.1	0.409 10.4	5,720 {2,600}	1,012 {460}	0.725 1.08	
OCM 60-SER	0.750 19.05	0.468 11.91	0.500 12.70	0.708 18.0	0.094 2.4	0.234 5.95	0.578 14.7	0.500 12.7	8,360 {3,800}	1,408 {640}	1.075 1.60	
OCM 80-SER	1.000 25.40	0.625 15.88	0.626 15.90	0.944 24.0	0.125 3.2	0.312 7.94	0.740 18.8	0.641 16.3	14,300 {6,500}	2,354 {1,070}	1.881 2.80	

OCM Chain No.	(A) Attachment					(K) Attachment		(SA-SK) Attachment		Additional Weight Per Attachment	
	K	N	A	E	G	(2A)B	(2G)H	M	F	A.SA(Lb/kg)	K.SK(Lb/kg)
OCM 40-SER	0.374 9.5	0.141 3.6	0.500 12.7	0.314 8.0	0.690 17.55	1.000 25.4	1.381 35.1	0.500 12.7	0.750 19.05	0.002 0.001	0.004 0.002
OCM 50-SER	0.500 12.7	0.204 5.2	0.626 15.9	0.405 10.3	0.909 23.1	1.252 31.8	1.818 46.2	0.627 15.95	0.994 25.25	0.008 0.004	0.017 0.008
OCM 60-SER	0.626 15.9	0.204 5.2	0.750 19.05	0.468 11.9	1.094 27.8	1.500 38.1	2.189 55.6	0.720 18.3	1.154 29.33	0.015 0.007	0.030 0.014
OCM 80-SER	0.751 19.1	0.267 6.8	1.000 25.4	0.626 15.9	1.276 32.4	2.000 50.8	2.551 64.8	0.968 24.6	1.366 34.7	0.024 0.011	0.048 0.022

# SELUBE SMALL CONVEYOR CHAIN

## SELUBE DOUBLE PITCH ROLLER CHAIN WITH ATTACHMENT

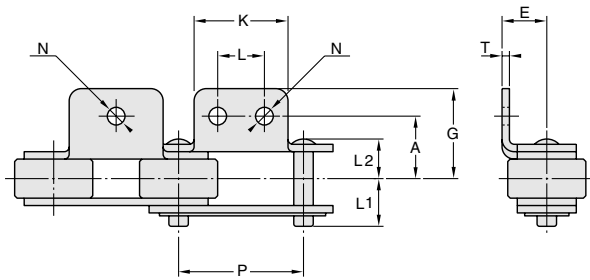

TYPE A-1 · 2

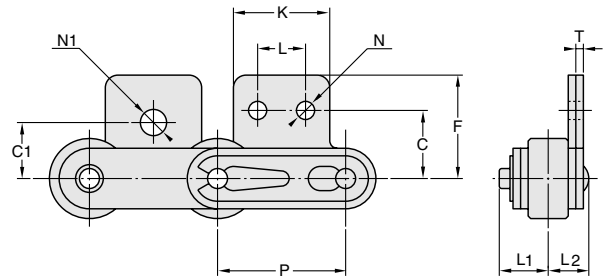

TYPE SA-1 · 2

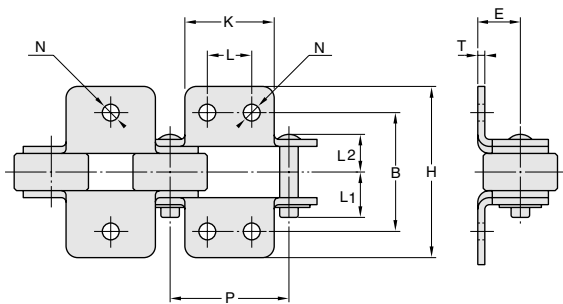

TYPE K-1 · 2

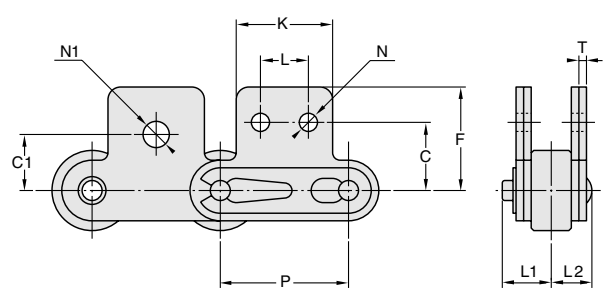

TYPE SK-1 · 2

UNIT Upper:inch  
Beneath:mm

OCM Chain No.	Pitch	Link Plate	(A) Attachment						(K) Attachment		(SA-SK) Attachment				Average Breaking Load Lb/kN{kgf}	Max. Allowable Load Lb/kN{kgf}	Additional Weight Per Att	
			P	T	K	N	L	A	E	G	(2A)B	(2G)H	C	F			C1	N1
OCM C2040-SER	1.000	0.059	0.750	0.142	0.375	0.500	0.358	0.780	1.000	1.559	0.531	0.807	0.437	0.205	3,520	616	0.006	0.013
OCM C2042-SER	25.40	1.5	19.1	3.6	9.5	12.7	9.1	19.8	25.4	39.6	13.5	20.5	11.1	5.2	15.69 {1,600}	2.75 { 280}	0.003	0.006
OCM C2050-SER	1.250	0.079	0.937	0.205	0.469	0.625	0.437	0.965	1.252	1.929	0.625	0.984	0.563	0.268	5,720	1,012	0.013	0.026
OCM C2052-SER	31.75	2.0	23.8	5.2	11.9	15.9	11.1	24.5	31.8	49.0	15.9	25.0	14.3	6.8	25.49 {2,600}	4.51 { 460}	0.006	0.012
OCM C2060H-SER	1.500	0.126	1.125	0.205	0.563	0.843	0.579	1.240	1.685	2.669	0.750	1.295	0.689	0.346	8,360	1,408	0.037	0.075
OCM C2062H-SER	38.10	3.2	28.6	5.2	14.3	21.4	14.7	31.5	42.8	67.8	19.1	32.9	17.5	8.8	37.26 {3,800}	6.27 { 640}	0.017	0.034
OCM C2080H-SER	2.000	0.157	1.500	0.268	0.750	1.094	0.750	1.602	2.189	3.457	1.000	1.713	0.875	0.413	14,300	2,354	0.082	0.163
OCM C2082H-SER	50.80	4.0	38.1	6.8	19.1	27.8	19.1	40.7	55.6	87.8	25.4	43.5	22.2	10.5	63.73 {6,500}	10.49 {1,070}	0.037	0.074

### CHAIN SELECTION

The selection procedure is the same as that for standard roller chain.

But note the following :

- (1) Operating temperature should be within a range of -10°C (14°F) to +150°C (300°F).
- (2) Chain should not be exposed to water and deoiling atmosphere.

The specifications described in this catalogue are subject to change without notice

# OCM EXTRA HEAVY DUTY ROLLER CHAIN

## EXTRA HEAVY DUTY ROLLER CHAIN

For tough applications, please consider using **OCM Extra Heavy Duty Roller Chain, HS Series, HSG Series and Special H Series roller chain.**

This strength is made possible by the following extra processes:

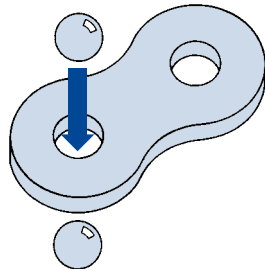

**Ball through**

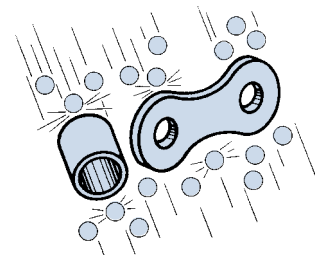

**Shot peening**



**Perfect lubrication**

Chain is prelubricated at a vacuum where air pockets are eliminated to help lubricant penetrate all bearing areas.



**Four stakes riveted**

TENSILE STRENGTH		WORKING LOAD	
HSG SERIES	118	HSG SERIES	125
HS SERIES	110	HS SERIES	120
OCM ANSI STANDARD	100	OCM ANSI STANDARD	100

**HS Series roller chain**

The main dimensions are identical to those of ANSI standard roller chain. HS Series roller chain can operate on standard sprockets. No offset is available. Connecting links are press fitted. S pin connecting link for 80 through 120 and Cotter for 140 through 240 are standard.

**HSG Series roller chain**

The thickness of link plate is thicker than standard roller chain.

**Special H Series**

Chain is developed for tough machinery and applications.

# EXTRA HEAVY DUTY CHAIN HS SERIES

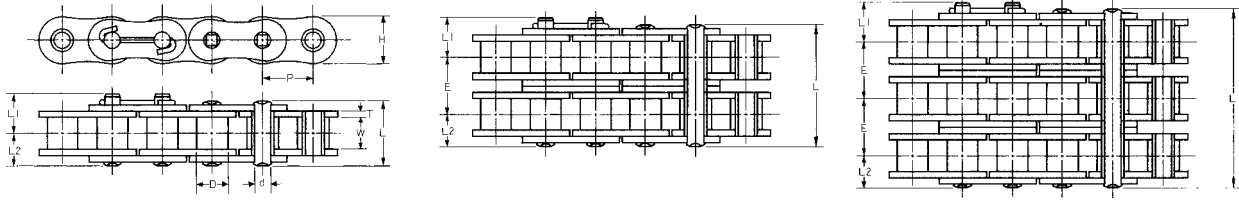

UNIT Upper:inch  
Beneath:mm

OCM Chain No.	Pitch	Roller Diam.	Width between L.P.	Link Plate		Pin Diam.	Pin			Trans Pitch	Average Tensile Strength	Max Working Load	Approx Weight
	P	D	W	H	T	d	L	L1	L2	E	Lb/kg	Lb/kg	Lb/ft kg/m
HS80	1.000	0.625	0.626	0.949	0.126	0.313	1.287	0.776	0.642	-	20,944	4,409	1.888
	25.4	15.88	15.9	24.1	3.2	7.94	32.7	19.7	16.3	-	9,500	2,000	2.81
HS80-2	1.000	0.625	0.626	0.949	0.126	0.313	2.445	0.776	0.642	1.154	41,888	7,496	3.776
	25.4	15.88	15.9	24.1	3.2	7.94	62.1	19.7	16.3	29.3	19,000	3,400	5.62
HS80-3	1.000	0.625	0.626	0.949	0.126	0.313	3.598	0.776	0.642	1.154	62,832	11,023	5.644
	25.4	15.88	15.9	24.1	3.2	7.94	91.4	19.7	16.3	29.3	28,500	5,000	8.4
HS100	1.250	0.750	0.754	1.185	0.157	0.375	1.571	0.925	0.787	-	29,762	6,834	2.856
	31.75	19.05	19.15	30.1	4	9.53	39.9	23.5	20	-	13,500	3,100	4.25
HS100-2	1.250	0.750	0.754	1.185	0.157	0.375	2.980	0.925	0.787	1.409	59,525	11,618	5.644
	31.75	19.05	19.15	30.1	4	9.53	75.7	23.5	20	35.8	27,000	5,270	8.4
HS100-3	1.250	0.750	0.754	1.185	0.157	0.375	4.394	0.925	0.787	1.409	89,287	17,086	8.466
	31.75	19.05	19.15	30.1	4	9.53	111.6	23.5	20	35.8	40,500	7,750	12.6
HS120	1.500	0.875	1.006	1.425	0.189	0.437	1.972	1.118	0.996	-	42,329	8,818	4.233
	38.1	22.23	25.55	36.2	4.8	11.11	50.1	28.4	25.3	-	19,200	4,000	6.3
HS120-2	1.500	0.875	1.006	1.425	0.189	0.437	3.764	1.118	0.996	1.787	84,657	14,991	8.359
	38.1	22.23	25.55	36.2	4.8	11.11	95.6	28.4	25.3	45.4	38,400	6,800	12.44
HS120-3	1.500	0.875	1.006	1.425	0.189	0.437	5.551	1.118	0.996	1.787	126,986	22,046	12.525
	38.1	22.23	25.55	36.2	4.8	11.11	141	28.4	25.3	45.4	57,600	10,000	18.64
HS140	1.750	1.000	1.012	1.661	0.220	0.500	2.083	1.234	1.041	-	55,116	11,684	5.362
	44.45	25.40	25.70	42.20	5.60	12.71	52.90	31.35	26.45	-	25,000	5,300	7.98
HS140-2	1.750	1.000	1.012	1.661	0.220	0.500	4.008	1.234	1.041	1.925	110,231	19,864	10.670
	44.45	25.40	25.70	42.20	5.60	12.71	101.80	31.35	26.45	48.90	50,000	9,010	15.88
HS140-3	1.750	1.000	1.012	1.661	0.220	0.500	5.933	1.234	1.041	1.925	165,347	29,233	15.972
	44.45	25.40	25.70	42.20	5.60	12.71	150.70	31.35	26.45	48.90	75,000	13,260	23.77
HS160	2.000	1.125	1.262	1.898	0.252	0.563	2.476	1.435	1.238	-	70,548	15,212	7.123
	50.8	28.58	32.05	48.2	6.4	14.29	62.9	36.45	31.45	-	32,000	6,900	10.6
HS160-2	2.000	1.125	1.262	1.898	0.252	0.563	4.78	1.435	1.238	2.303	141,096	25,860	14.178
	50.8	28.58	32.05	48.2	6.4	14.29	121.4	36.45	31.45	58.5	64,000	11,730	21.1
HS160-3	2.000	1.125	1.262	1.898	0.252	0.563	7.083	1.435	1.238	2.303	211,644	37,986	21.233
	50.8	28.58	32.05	48.2	6.4	14.29	179.9	36.45	31.45	58.5	96,000	17,230	31.6
HS200	2.500	1.562	1.512	2.374	0.315	0.781	3.063	1.811	1.531	-	113,538	21,826	11.739
	63.5	39.68	38.4	60.3	8	19.85	77.8	46	38.9	-	51,500	9,900	17.47
HS200-2	2.500	1.562	1.512	2.374	0.315	0.781	5.882	1.811	1.531	2.819	227,076	37,104	23.323
	63.5	39.68	38.4	60.3	8	19.85	149.4	46	38.9	71.6	103,000	16,830	34.71
HS200-3	2.500	1.562	1.512	2.374	0.315	0.781	8.701	1.811	1.531	2.819	340,614	52,911	34.9
	63.5	39.68	38.4	60.3	8	19.85	221	46	38.9	71.6	154,500	24,000	51.94
HS240	3.000	1.875	1.902	2.85	0.374	0.937	3.717	2.157	1.858	-	163,142	29,674	17.094
	76.2	47.63	48.3	72.4	9.5	23.81	94.4	54.8	47.2	-	74,000	13,460	25.44
HS240-2	3.000	1.875	1.902	2.85	0.374	0.937	7.173	2.157	1.858	3.457	326,284	50,596	33.98
	76.2	47.63	48.3	72.4	9.5	23.81	182.2	54.8	47.2	87.8	148,000	22,950	50.57
HS240-3	3.000	1.875	1.902	2.85	0.374	0.937	10.63	2.157	1.858	3.457	489,426	74,428	50.866
	76.2	47.63	48.3	72.4	9.5	23.81	270	54.8	47.2	87.8	222,000	33,760	75.7

Connecting link is press fit. S pin for 80 to 120 and cotter for 140 to 240. Offset link is not available.

EXTRA HEAVY DUTY ROLLER CHAIN



# EXTRA HEAVY DUTY CHAIN HSG SERIES

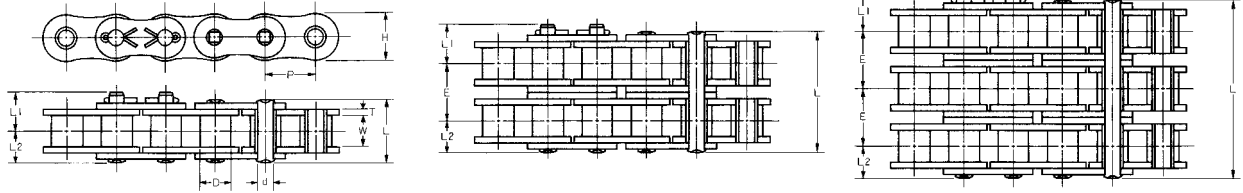

UNIT Upper:inch  
Beneath:mm

OCM Chain No.	Pitch	Roller Diam.	Width between L.P.	Link Plate		Pin Diam.	Pin			Trans Pitch	Average Tensile Strength	Max Working Load	Approx Weight
	P	D	W	H	T	d	L	L1	L2	E	Lb/kg	Lb/kg	Lb/ft kg/m
HSG80	1.000	0.625	0.630	0.949	0.157	0.313	1.398	0.821	0.699	-	22,046	4,850	2.197
	25.4	15.88	16	24.1	4	7.94	35.5	20.85	17.75	-	10,000	2,200	3.27
HSG80-2	1.000	0.625	0.630	0.949	0.157	0.313	2.681	0.821	0.699	1.283	44,092	8,245	4.361
	25.4	15.88	16	24.1	4	7.94	68.1	20.85	17.75	32.6	20,000	3,740	6.49
HSG80-3	1.000	0.625	0.630	0.949	0.157	0.313	3.587	0.821	0.699	1.283	66,139	12,103	6.524
	25.4	15.88	16	24.1	4	7.94	91.1	20.85	17.75	32.6	30,000	5,490	9.71
HSG100	1.250	0.750	0.756	1.185	0.189	0.376	1.677	0.969	0.839	-	32,628	7,275	3.225
	31.75	19.05	19.2	30.1	4.8	9.54	42.6	24.6	21.3	-	14,800	3,300	4.8
HSG100-2	1.250	0.750	0.756	1.185	0.189	0.376	3.217	0.969	0.839	1.539	65,257	12,368	6.41
	31.75	19.05	19.2	30.1	4.8	9.54	81.7	24.6	21.3	39.1	29,600	5,610	9.54
HSG100-3	1.250	0.750	0.756	1.185	0.189	0.376	4.756	0.969	0.839	1.539	97,885	18,188	9.595
	31.75	19.05	19.2	30.1	4.8	9.54	120.8	24.6	21.3	39.1	44,400	8,250	14.28
HSG120	1.500	0.875	1.006	1.425	0.220	0.437	2.079	1.177	1.039	-	44,092	9,678	4.643
	38.1	22.23	25.55	36.2	5.6	11.11	52.8	29.9	26.4	-	20,000	4,390	6.91
HSG120-2	1.500	0.875	1.006	1.425	0.220	0.437	4.004	1.177	1.039	1.925	88,185	16,491	9.239
	38.1	22.23	25.55	36.2	5.6	11.11	101.7	29.9	26.4	48.9	40,000	7,480	13.75
HSG120-3	1.500	0.875	1.006	1.425	0.220	0.437	5.929	1.177	1.039	1.925	132,277	24,273	13.835
	38.1	22.23	25.55	36.2	5.6	11.11	150.6	29.9	26.4	48.9	60,000	11,010	20.59
HSG140	1.750	1.000	1.012	1.661	0.252	0.500	2.213	1.299	1.106	-	57,320	12,346	5.92
	44.45	25.40	25.70	42.20	6.40	12.71	56.20	33.00	28.10	-	26,000	5,600	8.81
HSG140-2	1.750	1.000	1.012	1.661	0.252	0.500	4.268	1.299	1.106	2.055	114,640	20,988	11.779
	44.45	25.40	25.70	42.20	6.40	12.71	108.40	33.00	28.10	52.20	52,000	9,520	17.53
HSG140-3	1.750	1.000	1.012	1.661	0.252	0.500	6.323	1.299	1.106	2.055	171,960	30,799	17.638
	44.45	25.40	25.70	42.20	6.40	12.71	160.60	33.00	28.10	52.20	78,000	13,970	26.25
HSG160	2.000	1.125	1.268	1.898	0.280	0.563	2.606	1.500	1.303	-	72,752	15,631	7.694
	50.8	28.58	32.2	48.2	7.1	14.29	66.2	38.1	33.1	-	33,000	7,090	11.45
HSG160-2	2.000	1.125	1.268	1.898	0.280	0.563	5.043	1.500	1.303	2.437	145,505	26,522	15.313
	50.8	28.58	32.2	48.2	7.1	14.29	128.1	38.1	33.1	61.9	66,000	12,030	22.79
HSG160-3	2.000	1.125	1.268	1.898	0.280	0.563	7.480	1.500	1.303	2.437	218,257	39,110	22.933
	50.8	28.58	32.2	48.2	7.1	14.29	190	38.1	33.1	61.9	99,000	17,740	34.13
HSG200	2.500	1.562	1.531	2.374	0.374	0.781	3.327	1.943	1.663	-	130,073	24,736	13.251
	63.5	39.68	38.9	60.3	9.5	19.85	84.5	49.35	42.25	-	59,000	11,220	19.72
HSG200-2	2.500	1.562	1.531	2.374	0.374	0.781	6.409	1.943	1.663	3.083	260,145	42,263	26.34
	63.5	39.68	38.9	60.3	9.5	19.85	162.8	49.35	42.25	78.3	118,000	19,170	39.2
HSG200-3	2.500	1.562	1.531	2.374	0.374	0.781	9.492	1.943	1.663	3.083	390,218	62,281	39.436
	63.5	39.68	38.9	60.3	9.5	19.85	241.1	49.35	42.25	78.3	177,000	28,250	58.69

Connecting link is press fit. Offset link is not available.

# EXTRA HEAVY DUTY CHAIN SPECIAL H SERIES

This chain is designed for heavy duty application requiring compactness. For easy comparison, ANSI standard roller chain is listed.

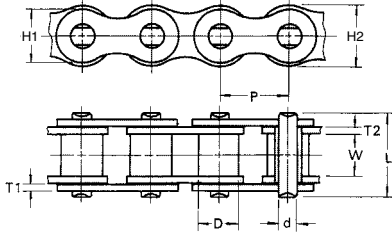

UNIT Upper:inch  
Beneath:mm

Chain No.	Pitch P	Roller Diam. D	Width between L.P. W	Link Plate				Pin Diam. d	Pin L	Average Tensile Strength Lb/kg	Max. Working Load Lb/kg	Approx Weight Lb/ft kg/m
				H1	H2	T1	T2					
ANSI 35	0.375 9.525	▲ 0.200 5.08	0.189 4.8	- -	0.354 9	0.049 1.25	0.049 1.25	0.141 3.58	0.461 11.7	2,601 1,180	419 190	0.24 0.36
2H33B 35H	0.375 9.525	▲ 0.200 5.08	0.189 4.8	0.358 9.1	0.358 9.1	0.079 2	0.079 2	0.141 3.58	0.583 14.8	3,902 1,770	728 330	0.36 0.53
ANSI 40	0.500 12.7	0.312 7.92	0.313 7.95	- -	0.472 12	0.059 1.5	0.059 1.5	0.156 3.96	0.634 16.1	4,299 1,950	860 390	0.44 0.66
HM45	0.500 12.7	0.335 8.5	0.313 7.95	0.492 12.5	0.492 12.5	0.063 1.6	0.079 2	0.177 4.5	0.697 17.7	5,952 2,700	1,146 520	0.6 0.9
HM45E	0.500 12.7	0.335 8.5	0.313 7.95	■ 0.472 12	■ 0.472 12	0.079 2	0.094 2.4	0.177 4.5	0.772 19.6	6,724 3,050	1,455 660	0.73 1.08
2H44E	0.500 12.7	0.306 7.77	0.252 6.4	■ 0.472 12	■ 0.472 12	0.059 1.5	0.079 2	0.156 3.96	0.634 16.1	5,181 2,350	1,235 560	0.52 0.78
2H45E 40H	0.500 12.7	0.312 7.92	0.313 7.95	■ 0.472 12	■ 0.472 12	0.059 1.5	0.079 2	0.156 3.96	0.689 17.5	5,181 2,350	1,235 560	0.56 0.83
ANSI 50	0.625 15.875	0.400 10.16	0.376 9.55	- -	0.591 15	0.079 2	0.079 2	0.200 5.08	0.799 20.3	7,165 3,250	1,389 630	0.73 1.08
H525E	0.625 15.875	0.421 10.7	0.311 7.9	■ 0.614 15.6	■ 0.614 15.6	0.094 2.4	0.126 3.2	0.206 5.24	0.874 22.2	10,141 4,600	2,646 1,200	1.08 1.6
2H52	0.625 15.875	0.400 10.16	0.252 6.4	0.512 13	0.594 15.1	0.094 2.4	0.094 2.4	0.200 5.08	0.736 18.7	8,818 4,000	1,543 700	0.67 1
2H53 50H	0.625 15.875	0.400 10.16	0.376 9.55	0.512 13	0.591 15	0.094 2.4	0.094 2.4	0.200 5.08	0.862 21.9	8,818 4,000	1,543 700	0.81 1.2
2H53S	0.625 15.875	0.400 10.16	0.376 9.55	0.512 13	■ 0.591 15	0.126 3.2	0.094 2.4	0.200 5.08	0.929 23.6	8,818 4,000	1,874 850	0.87 1.3
ANSI 60	0.750 19.05	0.469 11.91	0.500 12.7	- -	0.709 18	0.094 2.4	0.094 2.4	0.234 5.95	1.000 25.4	9,921 4,500	2,094 950	1.08 1.6
2H63	0.750 19.05	0.469 11.91	0.376 9.55	0.602 15.3	0.709 18	0.126 3.2	0.126 3.2	0.234 5.95	1.016 25.8	12,346 5,600	2,646 1,200	1.17 1.74
2H64	0.750 19.05	0.469 11.91	0.500 12.7	0.602 15.3	0.709 18	0.126 3.2	0.126 3.2	0.234 5.95	1.142 29	12,346 5,600	2,646 1,200	1.26 1.88
2H64B	0.750 19.05	▲ 0.469 11.91	0.504 12.79	0.787 20	0.787 20	0.126 3.2	0.157 4	0.295 7.5	1.236 31.4	18,188 8,250	3,384 1,535	1.68 2.5
3H63	0.750 19.05	0.469 11.91	0.376 9.55	0.709 18	0.787 20	0.126 3.2	0.126 3.2	0.234 5.95	1.016 25.8	13,007 5,900	3,351 1,520	1.34 2
4H63	0.750 19.05	0.563 14.29	0.376 9.55	■ 0.772 19.6	■ 0.772 19.6	0.126 3.2	0.157 4	0.276 7	1.071 27.2	16,314 7,400	4,034 1,830	1.73 2.58
5H63	0.750 19.05	0.563 14.29	0.376 9.55	■ 0.772 19.6	■ 0.772 19.6	0.126 3.2	0.161 4.1	0.287 7.3	1.079 27.4	17,416 7,900	4,034 1,830	1.73 2.58
H745E	0.875 22.225	0.614 15.6	0.563 14.3	■ 0.925 23.5	■ 0.925 23.5	0.157 4	0.189 4.8	0.313 7.94	1.409 35.8	23,369 10,600	5,952 2,700	2.55 3.8
H745B	0.875 22.225	▲ 0.563 14.29	0.563 14.29	0.925 23.5	0.925 23.5	0.157 4	0.189 4.8	0.354 9	1.425 36.2	26,015 11,800	4,696 2,130	2.42 3.6
H745EP	0.875 22.225	0.614 15.6	0.563 14.3	■ 0.925 23.5	■ 0.925 23.5	0.157 4	0.189 4.8	0.313 7.94	1.409 35.8	23,369 10,600	6,393 2,900	2.55 3.8
ANSI 80	1.000 25.4	0.625 15.88	0.626 15.9	- -	0.949 24.1	0.126 3.2	0.126 3.2	0.313 7.94	1.287 32.7	17,637 8,000	3,638 1,650	1.88 2.8
2H85E	1.000 25.4	0.625 15.88	0.626 15.9	■ 0.945 24	■ 0.945 24	0.126 3.2	0.157 4	0.313 7.94	1.362 34.6	21,605 9,800	5,071 2,300	2.22 3.3
3H85E	1.000 25.4	0.625 15.88	0.626 15.9	■ 0.945 24	■ 0.945 24	0.157 4	0.182 4.62	0.313 7.94	1.425 36.2	24,692 11,200	5,071 2,300	2.42 3.6
4H85E	1.000 25.4	0.625 15.88	0.626 15.9	■ 0.965 24.5	■ 0.965 24.5	0.157 4	0.182 4.62	0.326 8.28	1.472 37.4	28,440 12,900	6,173 2,800	2.62 3.9
H85B	1.000 25.4	▲ 0.625 15.88	0.626 15.9	1.047 26.6	1.047 26.6	0.189 4.8	0.220 5.6	0.394 10	1.654 42	32,408 14,700	6,305 2,860	3.09 4.6
H85	1.000 25.4	0.719 18.25	0.626 15.9	0.965 24.5	0.965 24.5	0.182 4.62	0.236 6	0.375 9.53	1.657 42.1	32,408 14,700	6,239 2,830	3.09 4.6
H85E	1.000 25.4	0.719 18.25	0.626 15.9	■ 0.965 24.5	■ 0.965 24.5	0.182 4.62	0.236 6	0.375 9.53	1.689 42.9	32,408 14,700	7,055 3,200	3.16 4.7
H955E	1.125 28.575	0.817 20.74	0.689 17.5	■ 1.098 27.9	■ 1.098 27.9	0.220 5.6	0.260 6.6	0.425 10.8	1.870 47.5	35,274 16,000	8,598 3,900	4.1 6.1
ANSI 100	1.250 31.75	0.750 19.05	0.754 19.15	- -	1.185 30.1	0.157 4	0.157 4	0.375 9.53	1.571 39.9	26,455 12,000	5,512 2,500	2.82 4.2

▲ indicates bush diameter. ■ indicates straight link plate.  
Most of chain is used endless. No connecting is available except some sizes.

# OCM MINI PITCH CHAIN

OCM mini pitch chain has a long standing reputation for its high precision and reliability. The chain is widely used in a positive and precision drive and control. OCM S10, the world's smallest chain, is used in various types of medical instruments.

## OCM MINI CHAIN

Chain No. **S10** Pitch • 0.125inch / 3.175mm

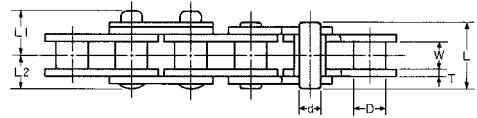
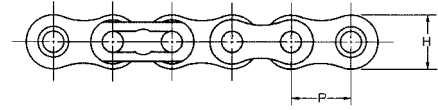

UNIT Upper:inch  
Beneath:mm

OCM Chain No.	Pitch	Roller Diam.	Width between L.P.	Link Plate		Pin Diam.	Pin			Average Tensile Strength	Approx Weight
	P	D	W	H	T	d	L	L1	L2	Lb/kg	Lb/ft kg/m
OCMS10	0.125 3.175	0.067 1.7	0.051 1.3	0.114 2.9	0.015 0.4	0.045 1.15	0.144 3.65	0.095 2.4	0.071 1.8	220 100	0.02 0.03

- Chain is rollerless. Offset is not available.
  - Connecting link is special type.
- Note: Dimensions subject to change. Certified dimensions furnished upon request.

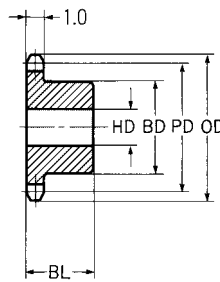

TYPE B

UNIT:mm

No. of Teeth	Pitch Diam. PD	Outside Diam. OD	Stock Bore HD	Max. Bore HD	Hub Diam. BD	Length thru Bore BL	Average Weight kg
10	10.27	11.6	3.0	4.0	6.5	7.0	0.002
11	11.27	12.7	3.0	4.5	7.0	7.0	0.002
12	12.27	13.7	3.0	5.0	8.0	8.0	0.003
13	13.27	14.7	3.0	5.5	9.0	8.0	0.004
14	14.27	15.8	3.0	6.5	10.0	8.0	0.005
15	15.27	16.8	4.0	7.0	11.0	8.0	0.006
16	16.27	17.8	4.0	8.0	12.0	8.0	0.007
17	17.28	18.8	4.0	8.0	13.0	8.0	0.009
18	18.28	19.9	4.0	9.0	14.0	8.0	0.010
19	19.29	20.9	5.0	10.0	15.0	8.0	0.011
20	20.30	21.9	5.0	10.0	16.0	8.0	0.013
21	21.30	22.9	5.0	12.0	17.0	10.0	0.018
22	22.31	23.9	5.0	12.0	18.0	10.0	0.020
23	23.32	25.0	5.0	13.0	19.0	10.0	0.022
24	24.32	26.0	5.0	14.0	20.0	10.0	0.025
25	25.33	27.0	6.0	14.0	21.0	10.0	0.026
26	26.34	28.0	6.0	14.0	22.0	10.0	0.029
27	27.35	29.0	6.0	15.0	23.0	10.0	0.032
28	28.36	30.0	6.0	15.0	24.0	10.0	0.035
29	29.37	31.0	6.0	16.0	25.0	12.0	0.045
30	30.37	32.1	6.0	16.0	25.0	12.0	0.046
31	31.38	33.1	6.0	16.0	25.0	12.0	0.046
32	32.39	34.1	6.0	16.0	25.0	12.0	0.047
33	33.40	35.1	6.0	16.0	25.0	12.0	0.047
34	34.41	36.1	6.0	16.0	25.0	12.0	0.048
35	35.42	37.1	6.0	16.0	25.0	12.0	0.048

- Teeth of sprockets are not induction hardened.
  - The max. bore showed above is general. Please determine your max. bore in view of your application and operating conditions.
- Note: Dimensions subject to change. Certified dimensions furnished upon request.

# OCM MINI CHAIN

Chain No. **15** Pitch ● 0.188inch / 4.7625mm

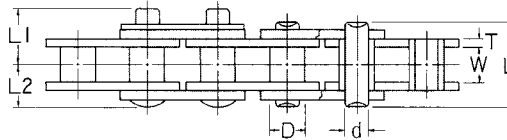
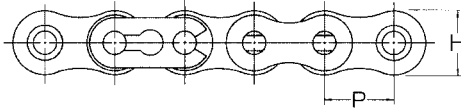

UNIT Upper:inch  
Beneath:mm

OCM Chain No.	Pitch	Roller Diam.	Width between L.P.	Link Plate		Pin Diam.	Pin			Average Tensile Strength	Approx Weight
	P	D	W	H	T	d	L	L1	L2	Lb/kg	Lb/ft kg/m
OCM15	0.188 4.7625	0.098 2.48	0.094 2.38	0.173 4.4	0.022 0.57	0.064 1.62	0.224 5.7	0.154 3.9	0.114 2.9	485 220	0.062 0.093

- Chain is rollerless. Offset is not available.
  - Connecting link is special type.
- Note : Dimensions subject to change. Certified dimensions furnished upon request.

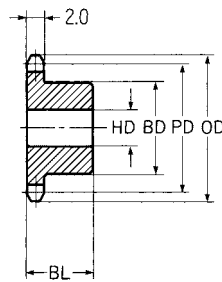

TYPE B

UNIT:mm

No. of Teeth	Pitch Diam.	Outside Diam.	Stock Bore	Max. Bore	Hub Diam.	Length thru Bore	Average Weight
	PD	OD	HD	HD	BD	BL	kg
10	15.41	17.5	4	6	10	10	0.007
11	16.90	19.0	4	7	11	10	0.008
12	18.40	20.5	4	8	12	10	0.010
13	19.90	22.0	4	9	14	10	0.014
14	21.40	23.5	6	10	15	12	0.017
15	22.91	25.0	6	12	17	12	0.022
16	24.41	26.5	6	12	18	12	0.025
17	25.92	28.0	8	14	20	14	0.032
18	27.43	29.5	8	14	22	14	0.039
19	28.93	31.0	8	15	23	14	0.044
20	30.44	32.5	8	15	24	14	0.048
21	31.95	34.0	8	17	26	14	0.057
22	33.46	35.5	8	17	27	14	0.062
23	34.98	37.5	8	17	28	14	0.067
24	36.49	39.0	8	20	30	16	0.087
25	38.00	40.5	8	20	32	16	0.099
26	39.51	42.0	10	22	33	16	0.103
27	41.02	43.5	10	25	35	16	0.116
28	42.54	45.0	10	25	36	16	0.130
29	44.05	46.5	10	25	38	16	0.138
30	45.56	48.0	10	25	39	16	0.146
31	47.07	49.5	10	25	40	18	0.173
32	48.59	51.0	10	25	40	18	0.175
33	50.10	52.5	10	25	40	18	0.177
34	51.62	54.0	10	25	40	18	0.178
35	53.13	55.5	10	25	40	18	0.180

- Teeth of sprockets are not induction hardened.
  - The max. bore showed above is general. Please determine your max. bore in view of your application and operating conditions.
- Note: Dimensions subject to change. Certified dimensions furnished upon request.

# OCM MINI CHAIN

Chain No. **25H** Pitch • 0.250inch / 6.35mm

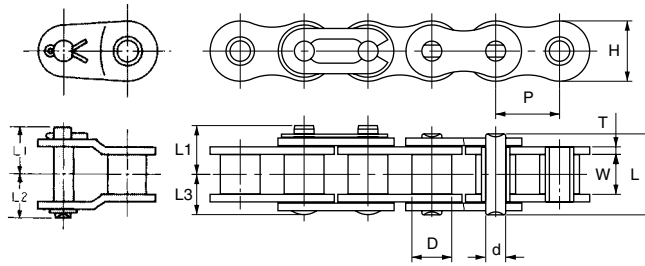

UNIT Upper:inch  
Beneath:mm

OCM Chain No.	Pitch	Roller Diam.	Width between L.P.	Link Plate		Pin Diam.	Pin				Trans Pitch	Average Tensile Strength	Max. Working Load	Approx Weight
	P	D	W	H	T	d	L	L1	L2	L3	E	Lb/kg	Lb/kg	Lb/ft
OCM25H	0.250 6.35	0.130 3.3	0.126 3.2	0.230 5.85	0.039 1.0	0.091 2.30	0.350 8.9	0.209 5.3	0.185 4.7	0.169 4.3	-	1147 520	209 95	0.107 0.16

- Chain is rollerless.
  - Connecting link is special type.
- Note : Dimensions subject to change. Certified dimensions furnished upon request.

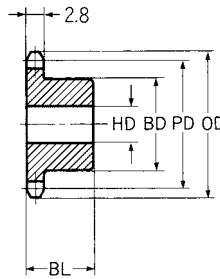

TYPE B

UNIT:mm

No. of Teeth	Pitch Diam. PD	Outside Diam. OD	Stock Bore HD	Max. Bore HD	Hub Diam. BD	Length thru Bore BL	Average Weight kg
10	20.55	23.0	6	8	13	12	0.01
11	22.54	25.0	6	9	15	12	0.02
12	24.53	27.5	6	11	17	12	0.02
13	26.53	29.5	6	13	19	12	0.03
14	28.54	31.5	8	13	20	14	0.04
15	30.54	33.5	8	15	22	14	0.04
16	32.55	35.5	8	15	24	14	0.05
17	34.56	37.5	8	17	26	14	0.06
18	36.57	39.5	8	17	28	14	0.07
19	38.58	41.5	8	20	30	16	0.09
20	40.59	43.5	8	20	32	16	0.11
21	42.61	45.5	10	25	34	16	0.12
22	44.62	47.5	10	25	36	16	0.13
23	46.63	50.0	10	25	38	16	0.14
24	48.65	52.0	10	25	40	18	0.18
25	50.66	54.0	10	25	40	18	0.18
26	52.68	56.0	10	25	40	18	0.19
27	54.70	58.0	10	25	40	18	0.19
28	56.71	60.0	10	25	40	18	0.19
29	58.73	62.0	10	25	40	18	0.20
30	60.75	64.0	10	25	40	18	0.20
31	62.77	66.0	10	25	40	18	0.21
32	64.78	68.0	10	25	40	18	0.21
33	66.80	70.0	10	25	40	18	0.22
34	68.82	72.0	10	25	40	18	0.22
35	70.84	74.0	10	25	40	18	0.23

- Teeth of sprockets are not induction hardened.
  - The max. bore showed above is general. Please determine your max. bore in view of your application and operating conditions.
- Note : Dimensions subject to change. Certified dimensions furnished upon request.

# OCM BS/DIN ROLLER CHAIN

## BS/DIN ROLLER CHAIN

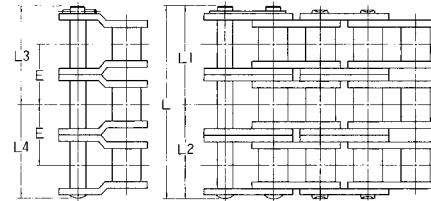
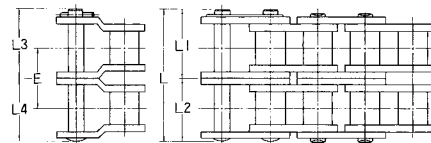
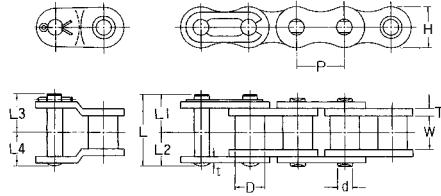

UNIT:mm

OCM Chain No.	ISO-B No.	Pitch P	Roller Diam. D	Width between L.P. W		Link Plate				Pin Diam. d	Pin					Trans Pitch E	Minimum Tensile Strength		Approx Weight kg/m
						H	T	t	L		L1	L2	L3	L4	kN		kg		
04	-	6.00	4	2.8	5	0.6	0.6	1.85	7.3	3.1	4.2	-	-	-	-	3.04	310	0.12	
05B	05B	8.00	5	3.2	7.1	0.75	0.75	2.3	8.7	4.8	3.9	4.8	4.1	-	4.61	470	0.18		
06B	06B	9.525	6.35	5.72	8.2	1.32	1.05	3.28	13.4	7.2	6.2	7.6	6.6	10.24	8.92	910	0.37		
06B-2									23.7	12.35	11.35	12.75	11.75		16.97	1730	0.70		
06B-3									34	17.5	16.5	17.85	16.85		24.91	2540	1.05		
08B	08B	12.70	8.51	7.85	11.8	1.62	1.62	4.45	18.3	9.8	8.5	10.6	8.5	13.92	17.85	1820	0.71		
08B-2									32.3	16.85	15.45	17.5	15.5		31.38	3200	1.30		
08B-3									46.2	23.8	22.4	24.5	22.4		45.11	4600	2.00		
10B	10B	15.875	10.16	9.8	14.7	1.62	1.62	5.08	21.2	11.6	9.6	11.7	9.7	16.59	22.26	2270	0.95		
10B-2									37.9	19.95	17.95	20	18		44.52	4540	1.80		
10B-3									54.5	28.25	26.25	28.3	26.3		66.78	6810	2.70		
12B	12B	19.05	12.07	11.7	16.1	1.88	1.88	5.72	24.3	13.1	11.2	13.6	11.3	19.46	28.93	2950	1.30		
12B-2									43.8	22.85	20.95	23.35	21.05		57.86	5900	2.50		
12B-3									63.3	32.6	30.7	33.1	30.8		86.79	8850	3.80		
16B	16B	25.40	15.88	17.05	21.08	4.1	3.2	8.28	38.2	20.2	18	21.7	20.2	31.88	63.74	6500	2.90		
16B-2									70	36	34	37.7	36.1		112.78	11500	5.60		
16B-3									101.8	51.9	49.9	53.6	52.1		170.642	17400	8.20		
20B	20B	31.75	19.05	19.6	26.4	4.4	3.5	10.19	44.4	23.7	20.7	24.6	23	36.45	98.07	10000	3.80		
20B-2									80.9	41.95	38.95	42.85	41.25		176.52	18000	7.40		
20B-3									117.3	60.2	57.1	61.05	59.45		259.88	26500	11.80		
24B	24B	38.10	25.4	25.4	33.4	5.9	4.9	14.61	58.7	32	26.7	32.9	30.7	48.36	166.71	17000	7.10		
24B-2									107.2	56.3	50.9	57.1	54.9		294.2	30000	13.90		
24B-3									155.5	80.4	75.1	81.3	79.1		446.2	45500	20.80		
28B	28B	44.45	27.94	31	36.7	7.4	6.3	15.88	70.2	37.7	32.5	38.9	36.6	59.56	200.06	20400	8.60		
28B-2									129.8	67.45	62.35	68.7	66.4		360.88	36800	16.60		
28B-3									189.4	97.3	92.1	98.5	96.2		539.37	55000	25.50		
32B	32B	50.80	29.2	31	41.9	6.9	6.3	17.79	71.1	37.7	33.4	38.4	36.6	58.55	254.97	26000	9.60		
32B-2									129.7	67	62.7	67.7	65.9		460.91	47000	18.7		
32B-3									188.2	96.25	91.95	97	95.2		686.47	70000	27.8		

1. Link Plate of 06B is Straight Side Bar type. 2. Connecting Link : 04 to 16B are Spring Clip type. 20B to 32B are Cotter Pin type.  
 3. Number of Middle Link Plate of 06B, 08B is 1 pc. 4. Offset Link of 04 is not available.

# BS/DIN STAINLESS ROLLER CHAIN

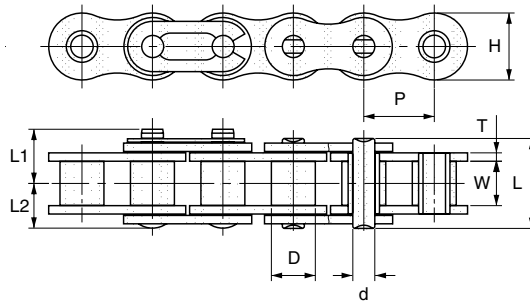

Material: 304 stainless steel  
UNIT:mm

OCM Chain No.	Pitch	Width between L.P.	Link Plate	Roller Diam.	Link Plate	Pin Diam.	Pin			Max Working Load	Approx Weight
	P	W	H	D	T	d	L	L1	L2		
04	6.00	2.80	4.90	4.00	0.60	1.85	7.35	-	-	6/0.06	0.11
05B	8.00	7.80	7.10	5.00	0.75	2.30	7.80	-	-	12/0.12	0.18
06B	9.525	5.72	8.20	6.35	1.27/1.0	3.28	13.75	7.25	6.50	27/0.26	0.39
08B	12.70	7.75	12.00	8.51	1.50	4.45	18.40	10.05	8.35	45/0.44	0.55
10B	15.875	9.65	14.70	10.16	1.50	5.08	19.10	11.25	9.55	70/0.70	0.94
12B	19.05	11.68	16.10	12.07	1.8/1.7	5.72	22.20	13.00	11.10	105/1.00	1.25
16B	25.40	17.02	20.30	15.88	4.0/3.2	8.26	35.10	20.60	17.60	210/2.06	2.59

Connecting link for 16B is cotter. 06B is straight link plate.

# BS/DIN NICKEL PLATED ROLLER CHAIN

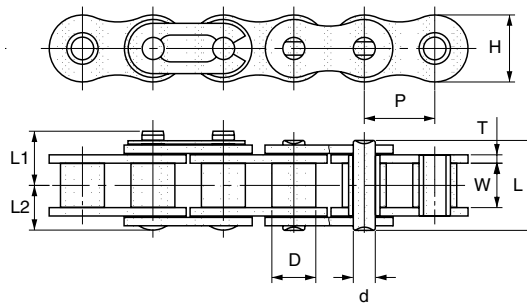

UNIT:mm

OCM Chain No.	ISO-B No.	Pitch	Roller Diam.	Width between L.P.	Link Plate			Pin Diam.	Pin				Minimum Tensile strength	Approx Weight
		P	D	W	H	T	t	d	L	L3	L1	L2		
04	-	6.00	4.00	2.80	5.00	0.60	0.60	1.85	7.30	3.10	-	-	310	0.12
05B	05B	8.00	5.00	3.20	7.10	0.75	0.75	2.30	8.70	3.90	-	-	470	0.18
06B	06B	9.525	6.35	5.72	8.20	1.32	1.05	3.28	13.40	7.20	7.60	6.60	910	0.37
08B	08B	12.70	8.51	7.85	11.80	1.62	1.62	4.45	18.30	9.80	10.60	8.50	1820	0.71
10B	10B	15.875	10.16	9.80	14.70	1.62	1.62	5.08	21.20	11.60	11.70	9.70	2270	0.95
12B	12B	19.05	12.07	11.70	16.10	1.88	1.88	5.72	24.30	13.10	13.60	11.30	2950	1.30
16B	16B	25.40	15.88	17.05	21.08	4.10	3.20	8.28	38.20	20.20	21.70	20.20	6500	2.90
20B	20B	31.75	19.02	19.60	26.00	4.40	3.50	10.16	43.85	23.70	25.15	23.00	10000	3.80
24B	24B	38.10	25.4	25.40	33.40	5.90	4.90	14.61	58.75	32.00	32.45	30.70	17000	7.10
28B	28B	44.45	27.94	31.00	36.70	7.40	6.30	15.88	70.45	37.70	39.10	36.30	20400	8.60
32B	32B	50.80	29.21	31.00	41.90	6.90	6.30	17.79	71.10	37.70	39.50	36.60	26000	9.60

t is pin link plate thickness.

# BS/DIN SELUBE CHAIN

OCM SELUBE CHAIN, being self-lubricating, provides excellent wear life, 8 to 30 times better than standard roller chain. ANSI and BS/DIN SELUBE CHAINS are available. SELUBE CHAIN is interchangeable with ANSI and BS/DIN standard roller chain. To prevent corrosion, pins are nickel plated and link plates are blackened.

Operating temperature within a range of -10°C (14°F) to 150°C (302°F)  
 Operating speed to be kept below 150m (490 feet) per minute

**Advantages**

- SELUBE CHAIN can be used where lubrication is prohibited or products should not be contaminated.
- No lubrication makes environment clean.
- Maintenance costs are reduced.
- Strength is almost the same as that of standard roller chain.
- Heat resistance up to 150°C.

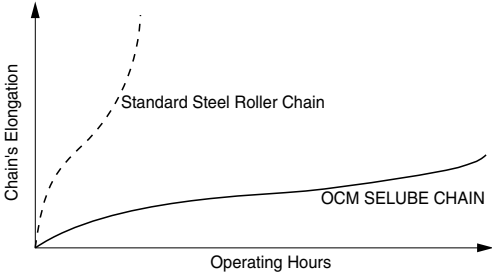

Blackened Link Plate    Nickel Plated Pin

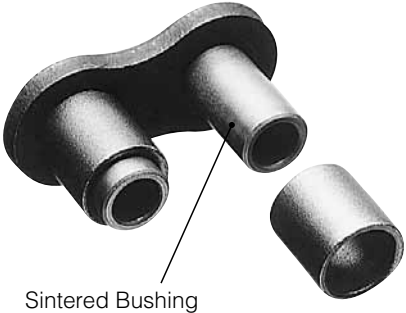
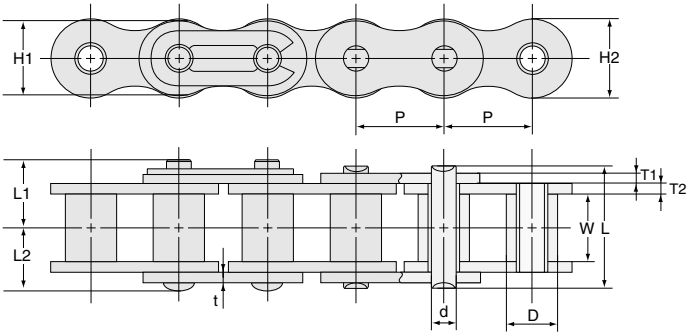

Sintered Bushing

UNIT:mm

OCM Chain No.	Pitch P	Roller Diam. D	Width between L.P. W	Link Plate				Pin Diam. d	Pin			Ultimate Tensile Strength kN	Approx Weight kg
				H1	H2	T1	T2		L	L1	L2		
OCM 08BJ-SER	12.70	8.50	7.85	10.9	11.8	1.56	2.00	4.45	17.70	10.20	8.90	19.4	0.77
OCM 10BJ-SER	15.875	10.16	9.80	13.7	14.7	1.56	2.00	5.08	20.20	12.00	10.10	26.0	1.03
OCM 12BJ-SER	19.05	12.07	11.70	16.1	16.1	1.82	2.40	5.72	23.60	13.60	11.80	35.3	1.40

The Specifications described in this catalogue are subject to change without notice. Certified specifications will be furnished upon request.



## STAINLESS ROLLER CHAIN

### 1. Stainless Roller Chain SUS Series

This chain is made of 304 (austenitic) stainless steel. This chain has excellent corrosive resistance and very low magnetic permeability.

This chain is good for general acid, alkali and water. Heat resistance.

### 2. Stainless Roller Chain SAC Series

This chain is made of 316 (austenitic) stainless steel. This is better in corrosion resistance than SUS Series and non-magnetic. Spring clips and cotters used are made of 304 stainless steel. Heat resistance.

### 3. Stainless Roller Chain SPH Series

The pin, bush and roller of this chain are made of 600 Series precipitation hardened stainless steel with link plate of 304 stainless steel. Spring clips and cotters used are made of 304 stainless steel. Magnetic.

Better wear resistance. The working load of this chain is 1.5 times SUS Series.

### 4. Super Shield Chain

A tough protective coating is baked onto the chain. This chain is better than nickel plated chain in corrosion resistance. The tensile strength is slightly lower than standard roller chain. Please avoid using this chain for the applications requiring resistance to acids and in direct contact with food. When you need a chain for corrosion resistance to salt water, rain water, etc, use SUPER SHIELD.

### 5. Nickel Plated Chain

Assembled from special nickel plated components. This chain with good corrosion resistance and beautiful surface appearance is used for food machinery, office machinery, etc.

### 6. Cold Resistance Chain K Series

This chain is identical in dimension with standard roller chain but can be used at a temperature of  $-30^{\circ}\text{C}$ ~ $60^{\circ}\text{C}$ .

# ANSI STAINLESS ROLLER CHAIN

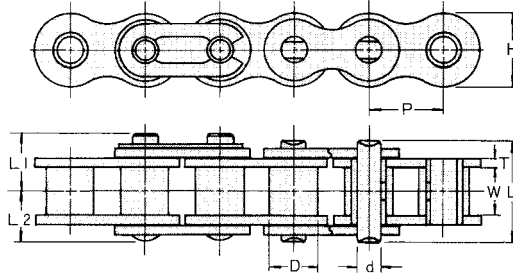
UNIT Upper:inch  
Beneath:mm

OCM Chain No.	Pitch	Roller Diam.	Width between L.P.	Link Plate		Pin Diam.	Pin			Max Working Load	Approx Weight Lb/ft
	P	D	W	H	T	d	L	L1	L2	Lb/kgf	kg/m
OCM 15SUS	0.188	0.098	0.094	0.173	0.022	0.064	0.224	0.154	0.114	11	0.062
	4.7625	2.48	2.38	* 4.40	0.57	1.62	5.70	3.90	2.90	5	0.093
OCM 25SUS	0.25	0.13	0.126	0.23	0.03	0.091	0.307	0.189	0.154	26	0.087
	6.35	3.30	3.20	* 5.85	0.75	2.30	7.80	4.80	3.90	12	0.13
OCM 35SUS	0.375	0.2	0.189	0.354	0.049	0.141	0.465	0.264	0.24	66	0.249
	9.525	5.08	4.80	* 9.00	1.25	3.58	11.80	6.70	6.10	30	0.37
OCM 40SUS	0.50	0.312	0.313	0.472	0.059	0.156	0.654	0.402	0.323	99	0.403
	12.70	7.92	7.95	12.00	1.50	3.96	16.60	10.20	8.20	45	0.6
OCM 50SUS	0.625	0.4	0.376	0.591	0.079	0.2	0.819	0.48	0.406	165	0.632
	15.875	10.16	9.55	15.00	2.00	5.08	20.80	12.20	10.30	75	0.94
OCM 60SUS	0.75	0.469	0.5	0.709	0.094	0.234	1.02	0.598	0.5	231	0.941
	19.05	11.91	12.70	18.00	2.40	5.95	25.90	15.20	12.70	105	1.4
OCM 80SUS	1.00	0.625	0.626	0.945	0.126	0.313	1.299	0.76	0.65	397	1.68
	25.40	15.88	15.90	24.00	3.20	7.94	33.00	19.30	16.50	180	2.5
OCM 100SUS	1.25	0.75	0.754	1.181	0.157	0.375	1.701	0.909	0.791	573	2.553
	31.75	19.05	19.15	30.00	4.00	9.53	43.20	23.10	20.10	260	3.8
OCM 120SUS	1.50	0.875	1.006	1.417	0.189	0.437	2.114	1.118	0.996	882	3.696
	38.10	22.23	25.55	36.00	4.80	11.11	53.70	28.40	25.30	400	5.5

Connecting link for 80 and above is cotter type.  
\* indicates bush diameters.UNIT Upper:inch  
Beneath:mm

OCM Chain No.	Pitch	Roller Diam.	Width between L.P.	Link Plate		Pin Diam.	Pin			Max Working Load	Approx Weight Lb/ft
	P	D	W	H	T	d	L	L1	L2	Lb/kgf	kg/m
OCM 40SPH	0.50	0.312	0.313	0.472	0.059	0.156	0.654	0.402	0.323	154	0.403
	12.7	7.92	7.95	12	1.5	3.96	16.6	10.2	8.2	70	0.6
OCM 50SPH	0.625	0.4	0.376	0.591	0.079	0.2	0.819	0.48	0.406	231	0.632
	15.875	10.16	9.55	15	2	5.08	20.8	12.2	10.3	105	0.94
OCM 60SPH	0.75	0.469	0.5	0.709	0.094	0.234	1.02	0.598	0.5	353	0.941
	19.05	11.91	12.7	18	2.4	5.95	25.9	15.2	12.7	160	1.4
OCM 80SPH	1.00	0.625	0.626	0.945	0.126	0.313	1.299	0.76	0.65	595	1.68
	25.4	15.88	15.9	24	3.2	7.94	33	19.3	16.5	270	2.5

UNIT Upper:inch  
Beneath:mm

OCM Chain No.	Pitch	Roller Diam.	Width between L.P.	Link Plate		Pin Diam.	Pin			Max Working Load	Approx Weight Lb/ft
	P	D	W	H	T	d	L	L1	L2	Lb/kgf	kg/m
OCM 40SAC	0.50	0.312	0.313	0.472	0.059	0.156	0.654	0.402	0.323	99	0.403
	12.7	7.92	7.95	12	1.5	3.96	16.6	10.2	8.2	45	0.6
OCM 50SAC	0.63	0.4	0.376	0.591	0.079	0.2	0.819	0.48	0.406	165	0.632
	15.875	10.16	9.55	15	2	5.08	20.8	12.2	10.3	75	0.94
OCM 60SAC	0.75	0.469	0.5	0.709	0.094	0.234	1.02	0.598	0.5	231	0.941
	19.05	11.91	12.7	18	2.4	5.95	25.9	15.2	12.7	105	1.4
OCM 80SAC	1.00	0.625	0.626	0.945	0.126	0.313	1.299	0.76	0.65	397	1.68
	25.4	15.88	15.9	24	3.2	7.94	33	19.3	16.5	180	2.5

# STAINLESS DOUBLE PITCH ROLLER CHAIN

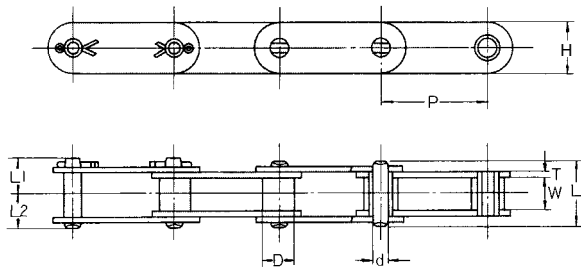

SMALL ROLLER

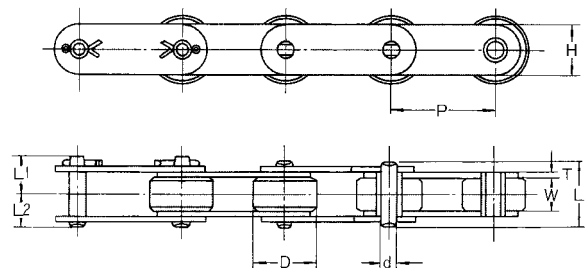

LARGE ROLLER

SMALL ROLLER

UNIT Upper:inch  
Beneath:mm

OCM Chain No.	Pitch	Roller Diam.	Width between L.P.	Link Plate		Pin Diam.	Pin			Max Working Load	Approx Weight
	P	D	W	H	T	d	L	L1	L2	Lb/kgf	Lb/ft kg/m
C2040SUS	1.000	0.312	0.313	0.472	0.059	0.156	0.654	0.402	0.323	99	0.34
	25.4	7.92	7.95	12	1.5	3.96	16.6	10.2	8.2	45	0.51
C2050SUS	1.250	0.4	0.376	0.591	0.079	0.2	0.819	0.476	0.409	165	0.58
	31.75	10.16	9.55	15	2	5.08	20.8	12.1	10.4	75	0.87
C2060HSUS	1.500	0.469	0.5	0.677	0.126	0.234	1.142	0.669	0.563	231	1.01
	38.1	11.91	12.7	17.2	3.2	5.95	29	17	14.3	105	1.51
C2080HSUS	2.000	0.625	0.626	0.945	0.157	0.313	1.437	0.839	0.709	397	1.79
	50.8	15.88	15.9	24	4	7.94	36.5	21.3	18	180	2.66

LARGE ROLLER

UNIT Upper:inch  
Beneath:mm

OCM Chain No.	Pitch	Roller Diam.	Width between L.P.	Link Plate		Pin Diam.	Pin			Max Working Load	Approx Weight
	P	D	W	H	T	d	L	L1	L2	Lb/kgf	Lb/ft kg/m
C2042SUS	1.000	0.625	0.313	0.472	0.059	0.156	0.654	0.402	0.323	99	0.58
	25.4	15.88	7.95	12	1.5	3.96	16.6	10.2	8.2	45	0.87
C2052SUS	1.250	0.75	0.376	0.591	0.079	0.2	0.819	0.476	0.409	165	0.91
	31.75	19.05	9.55	15	2	5.08	20.8	12.1	10.4	75	1.35
C2062HSUS	1.500	0.875	0.5	0.677	0.126	0.234	1.142	0.669	0.563	231	1.47
	38.1	22.23	12.7	17.2	3.2	5.95	29	17	14.3	105	2.19
C2082HSUS	2.000	1.125	0.626	0.945	0.157	0.313	1.437	0.839	0.709	397	2.47
	50.8	28.58	15.9	24	4	7.94	36.5	21.3	18	180	3.68

Note: Connecting link for C2040/C2042 to C2060H/C2060H is spring clip while C2080H/C2082H and above is cotter type.

OCM Chain No.	OCM Chain No.	Max working load		OCM Chain No.	OCM Chain No.	Max working load	
		kgf	Lbs			kgf	Lbs
C2040-SAC	C2042-SAC	45	99	C2040-SPH	C2042-SPH	70	154
C2050-SAC	C2052-SAC	75	165	C2050-SPH	C2052-SPH	105	231
C2060H-SAC	C2062H-SAC	105	231	C2060H-SPH	C2062H-SPH	160	353
C2080H-SAC	C2082H-SAC	180	397	C2080H-SPH	C2082H-SPH	270	595

Dimensions of SAC and SPH are the same as SUS.

# STAINLESS HOLLOW PIN CHAIN

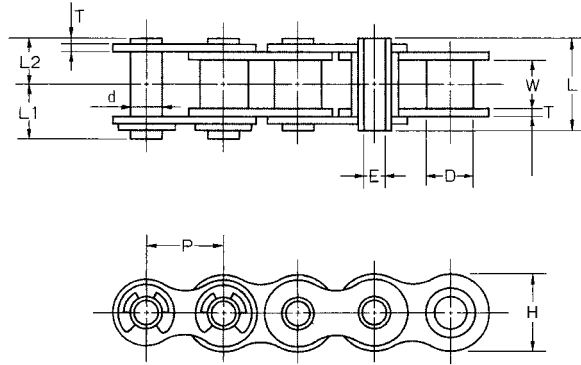

CHAIN IS ROLLERLESS

UNIT Upper:inch  
Beneath:mm

OCM Chain No.	Pitch	Roller Diam.	Width between L.P.	Pin Diam.	Trans Pitch	Pin			Link Plate		Allowable Load	Approx Weight
	P	D	W	d	E (MIN)	L	L1	L2	H	T	Lb/kgf	Lb/ft kg/m
40HP SUS	0.500 12.7	0.312 7.92	0.313 7.95	0.222 5.65	0.157 4	0.63 16	0.362 9.2	0.315 8	0.472 12	0.059 1.5	99 45	0.34 0.51
50HP SUS	0.625 15.875	0.4 10.16	0.376 9.55	0.284 7.21	0.202 5.12	0.799 20.3	0.451 11.45	0.4 10.15	0.591 15	0.079 2	165 75	0.56 0.84
60HP SUS	0.750 19.05	0.469 11.91	0.5 12.7	0.327 8.3	0.236 6	1 25.4	0.559 14.2	0.5 12.7	0.709 18	0.094 2.4	231 105	0.83 1.23
80HP SUS	1.000 25.4	0.625 15.88	0.626 15.9	0.433 11	0.315 8	1.287 32.7	0.703 17.85	0.644 16.35	0.949 24.1	0.126 3.2	397 180	1.48 2.2

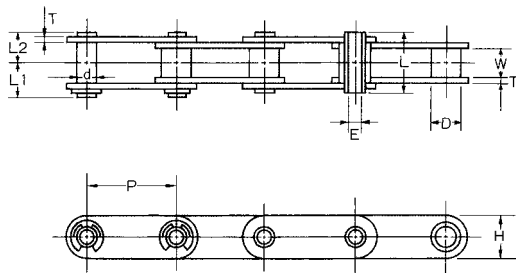

TYPE ROLLERLESS

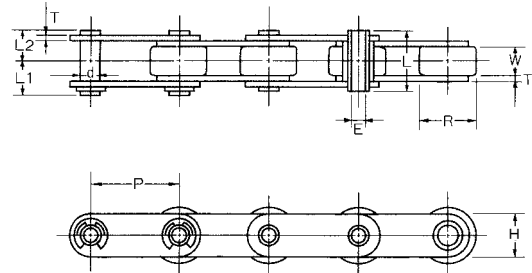

TYPE LARGE ROLLER

UNIT Upper:inch  
Beneath:mm

OCM Chain No.	Pitch	Roller Diam.		Width between L.P.	Pin Diam.		Pin			Link Plate		Allowable Load	Approx Weight	
	P	D	R	W	d	E(MIN)	L	L1	L2	H	T	Lb/kgf	Lb/ft kg/m	
C2040HP-C2042HP SUS	1.000 25.4	0.312 7.92	0.625 15.88	0.313 7.95	0.222 5.65	0.157 4	0.63 16	0.362 9.2	0.315 8	0.472 12	0.059 1.5	99 45	0.3 0.45	0.53 0.79
C2050HP-C2052HP SUS	1.250 31.75	0.4 10.16	0.75 19.05	0.376 9.55	0.284 7.21	0.202 5.12	0.799 20.3	0.451 11.45	0.4 10.15	0.591 15	0.079 2	165 75	0.5 0.74	0.8 1.19
C2060HP-C2062HP SUS	1.500 38.1	0.469 11.91	0.875 22.23	0.5 12.7	0.327 8.3	0.236 6	1 25.4	0.559 14.2	0.5 12.7	0.677 17.2	0.094 2.4	231 105	0.69 1.02	1.15 1.71
C2080HP-C2082HP SUS	2.000 50.8	0.625 15.88	1.125 28.58	0.626 15.9	0.433 11	0.315 8	1.287 32.7	0.703 17.85	0.644 16.35	0.945 24	0.126 3.2	397 180	1.28 1.91	1.98 2.94

# SUPER SHIELD CHAIN

SUPER SHIELD CHAIN by OCM is a corrosion resistant chain for areas exposed directly to water. Second only to OCM's stainless steel roller chain in corrosion resistance, SUPER SHIELD CHAIN also retains almost the strength of standard roller chain.

A tough protective coating is baked onto the chain, providing corrosion resistance up to 250°C. When you need a chain for corrosion resistance to salt water, rain water, etc., use SUPER SHIELD CHAIN.

When addressing contact with food or other applications requiring resistance to acids, use OCM's stainless steel roller chain products.

Test Result – See the pictures shown on the right –

Chain was sprayed with salt water. The test was made in accordance with JIS Z2371, Japan Industrial Standard.

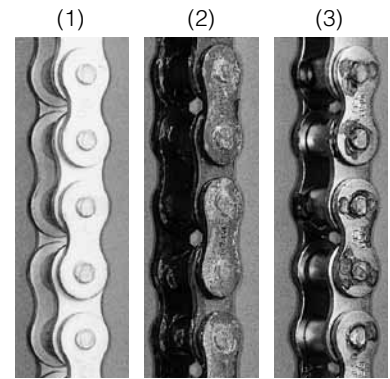

Chain after 72 hours elapsed

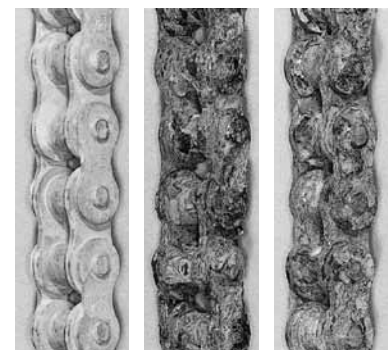

Chain after 504 hours elapsed

- (1) OCM SUPER SHIELD CHAIN
- (2) Competitor's Equivalent
- (3) OCM Nickel Plated Chain

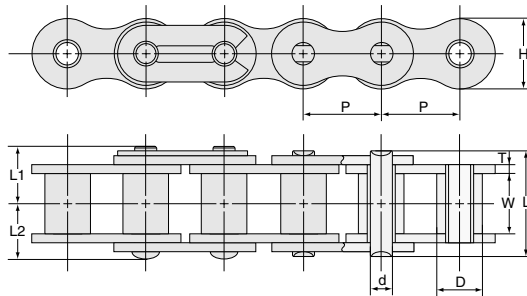

UNIT Upper:inch  
Beneath:mm

OCM Chain No.	Pitch P	Roller Diam. D	Width between L.P. W	Link Plate		Pin Diam. d	Pin			Ultimate Tensile Strength Lb/kgf	Max. Working Load Lb/kgf	Approx Weight Lb/ft kg/m	
				H	T		L	L1	L2				
ANSI ROLLER CHAIN	OCM35 SC	0.375 9.525	0.200 5.080	0.189 4.80	0.355 9.00	0.049 1.25	0.141 3.58	0.461 11.7	0.264 6.7	0.240 6.1	1,985 900	419 190	0.242 0.36
	OCM40 SC	0.500 12.70	0.313 7.940	0.313 7.95	0.473 12.00	0.059 1.50	0.156 3.96	0.634 16.1	0.382 9.7	0.319 8.1	3,175 1,440	860 390	0.443 0.66
	OCM50 SC	0.625 15.875	0.400 10.16	0.376 9.55	0.591 15.00	0.079 2.00	0.200 5.08	0.800 20.3	0.477 12.1	0.410 10.4	5,358 2,430	1,389 630	0.713 1.08
	OCM60 SC	0.750 19.05	0.469 11.91	0.500 12.70	0.709 18.00	0.095 2.40	0.234 5.95	1.001 25.4	0.579 14.7	0.500 12.7	7,641 3,465	2,095 950	1.067 1.6
	OCM80 SC	1.000 25.40	0.625 15.88	0.627 15.90	0.949 24.10	0.126 3.20	0.313 7.94	1.289 32.7	0.741 18.8	0.709 18.0	14,289 6,480	3,638 1,650	1.868 2.8
	OCM100 SC	1.250 31.75	0.750 19.05	0.755 19.15	1.185 30.10	0.158 4.00	0.375 9.53	1.698 43.1	0.925 23.5	0.787 20.0	21,434 9,720	5,513 2,500	2.801 4.2
	OCM120 SC	1.500 38.10	0.876 22.23	1.007 25.55	1.425 36.20	0.189 4.80	0.438 11.11	2.124 53.9	1.119 28.4	0.989 25.1	29,967 13,590	7,277 3,300	4.135 6.2
BS ROLLER CHAIN	OCM06B SC	0.375 9.525	0.250 6.35	0.225 5.72	0.323 8.20	0.052 1.32	0.129 3.28	0.528 13.4	0.283 7.2	0.244 6.2	1,805 819	- -	0.246 0.37
	OCM08B SC	0.500 12.70	0.335 8.51	0.309 7.85	0.464 11.80	0.063 1.62	0.175 4.45	0.720 18.3	0.386 9.8	0.335 8.5	3,611 1,638	- -	0.473 0.71
	OCM10B SC	0.625 15.875	0.400 10.16	0.386 9.80	0.579 14.70	0.063 1.62	0.200 5.08	0.835 21.2	0.457 11.6	0.378 9.6	4,504 2,043	- -	0.633 0.95
	OCM12B SC	0.750 19.05	0.475 12.07	0.460 11.70	0.634 16.10	0.074 1.88	0.225 5.72	0.956 24.3	0.516 13.1	0.441 11.2	5,854 2,655	- -	0.867 1.3
	OCM16B SC	1.000 25.40	0.625 15.88	0.671 17.05	0.830 21.08	0.161 4.10	0.326 8.28	1.504 38.2	0.795 20.2	0.709 18.0	12,899 5,850	- -	1.934 2.9
	OCM20B SC	1.250 31.75	0.750 19.05	0.771 19.60	1.039 26.40	0.173 4.40	0.401 10.19	1.748 44.4	0.933 23.7	0.815 20.7	19,845 9,000	- -	2.535 3.8
	OCM24B SC	1.500 38.10	1.000 25.40	1.000 25.40	1.315 33.40	0.232 5.90	0.575 14.61	2.311 58.7	1.260 32.0	1.051 26.7	33,736 15,300	- -	4.736 7.1

ANSI: 25H thru 240, BS: 06B thru 32B is available

# NICKEL PLATED ROLLER CHAIN

OCM nickel plated chains provide stronger corrosion resistance than steel chains at low cost. Nickel plate prior to assembly or after assembly is available.

Plating is available for ANSI 25 through 200 and double pitch roller chains.

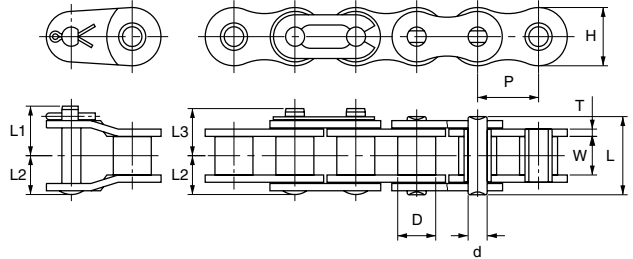

UNIT Upper:inch  
Beneath:mm

OCM Chain No.	Pitch		Roller Diam. D	Width between L.P.			Pin Diam. d	Pin				Trans Pitch E	Average Tensile Strength	Max Working Load	Approx Weight
	P	D		H	T	L		L1	L2	L3	Lb/kgf				
S10N	0.125	0.067	0.051	0.114	0.016	0.045	0.144	-	0.077	0.096	-	220	44	0.02	
	3.175	1.7	1.3	2.9	0.4	1.15	3.65	-	1.95	2.45	-	100	20	0.03	
15N	0.188	0.098	0.094	0.173	0.022	0.064	0.224	-	0.114	0.154	-	485	88	0.06	
	4.765	2.48	2.38	4.4	0.57	1.62	5.7	-	2.9	3.9	-	220	40	0.09	
25N	0.250	0.13	0.126	0.23	0.03	0.091	0.307	0.189	0.161	0.189	0.252	1058	154	0.09	
	6.35	3.3	3.2	5.85	0.75	2.3	7.8	4.8	4.1	4.8	6.4	480	70	0.13	
35N	0.375	0.2	0.189	0.354	0.049	0.141	0.461	0.264	0.252	0.264	0.398	2601	419	0.25	
	9.525	5.08	4.8	9	1.25	3.58	11.7	6.7	6.4	6.7	10.1	1180	190	0.37	
40N	0.500	0.312	0.313	0.472	0.059	0.156	0.634	0.402	0.319	0.382	0.567	4299	860	0.40	
	12.7	7.92	7.95	12	1.5	3.96	16.1	10.2	8.1	9.7	14.4	1950	390	0.6	
50N	0.625	0.4	0.376	0.591	0.079	0.2	0.799	0.476	0.409	0.476	0.713	7165	1389	0.63	
	15.875	10.16	9.55	15	2	5.08	20.3	12.1	10.4	12.1	18.1	3250	630	0.94	
60N	0.750	0.469	0.5	0.709	0.094	0.234	1	0.598	0.5	0.579	0.898	9921	2094	0.94	
	19.05	11.91	12.7	18	2.4	5.95	25.4	15.2	12.7	14.7	22.8	4500	950	1.4	
80N	1.000	0.625	0.626	0.949	0.126	0.313	1.287	0.776	0.642	0.74	1.154	17637	3638	1.81	
	25.4	15.88	15.9	24.1	3.2	7.94	32.7	19.7	16.3	18.8	29.3	8000	1650	2.7	
100N	1.250	0.75	0.754	1.185	0.157	0.375	1.697	0.925	0.787	0.925	1.409	26455	5512	2.82	
	31.75	19.05	19.15	30.1	4	9.53	43.1	23.5	20	23.5	35.8	12000	2500	4.2	

# CHAIN FOR LOW TEMPERATURE

This chain is built for a temperature of -30°C(-22°F) to 60°C(140°F).

The chain is dimensionally the same as ANSI standard roller chain.

UNIT Upper:inch  
Beneath:mm

OCM Chain No.	Pitch		Roller Diam. D	Width between L.P.			Pin Diam. d	Pin				Trans Pitch E	Average Tensile Strength	Max Working Load	Approx Weight
	P	D		H	T	L		L1	L2	L3	Lb/kgf				
40K	0.50	0.312	0.313	0.472	0.059	0.156	0.634	0.402	0.319	0.382	0.567	4299	683	0.403	
	12.7	7.92	7.95	12	1.5	3.96	16.1	10.2	8.1	9.7	14.4	1950	310	0.6	
50K	0.625	0.4	0.376	0.591	0.079	0.2	0.799	0.476	0.409	0.476	0.713	7165	1102	0.632	
	15.875	10.16	9.55	15	2	5.08	20.3	12.1	10.4	12.1	18.1	3250	500	0.94	
60K	0.75	0.469	0.5	0.709	0.094	0.234	1	0.598	0.5	0.579	0.898	9921	1676	0.941	
	19.05	11.91	12.7	18	2.4	5.95	25.4	15.2	12.7	14.7	22.8	4500	760	1.4	
80K	1.00	0.625	0.626	0.949	0.126	0.313	1.287	0.776	0.642	0.74	1.154	17637	2910	1.814	
	25.4	15.88	15.9	24.1	3.2	7.94	32.7	19.7	16.3	18.8	29.3	8000	1320	2.7	
100K	1.25	0.75	0.754	1.185	0.157	0.375	1.697	0.925	0.787	0.925	1.409	26455	4409	2.822	
	31.75	19.05	19.15	30.1	4	9.53	43.1	23.5	20	23.5	35.8	12000	2000	4.2	
120K	1.50	0.875	1.006	1.425	0.189	0.437	2.106	1.118	1.071	0.988	1.787	37038	5820	4.166	
	38.1	22.23	25.55	36.2	4.8	11.11	53.5	28.4	27.2	25.1	45.4	16800	2640	6.2	

# OCM PLASTIC CHAIN

## PLAMATE CHAIN

Plamate chain is made up of plastic roller link with either stainless link plate and pin (PS) or nickel plated link plate and pin (PN).

No lubrication, clean and light in weight.

Usable in temperature up to 70°C from -10°C. The max chain speed should be less than 70m/min. No offset is available. Use even number of pitches.

Plamate can operate on ANSI standard sprockets.

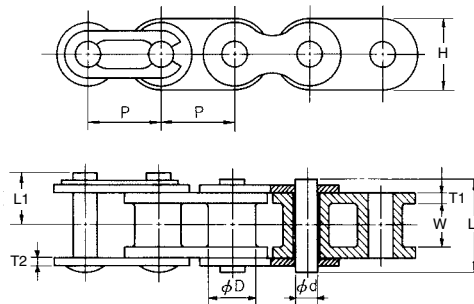
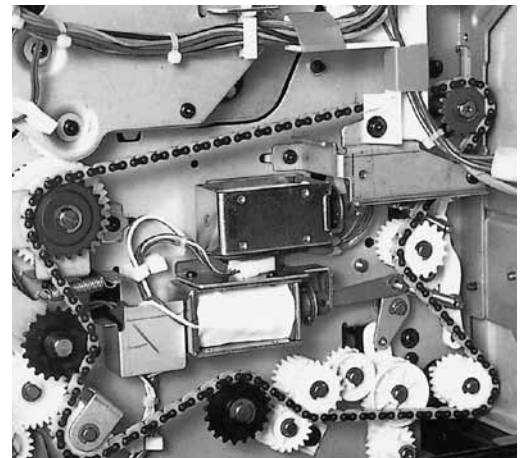
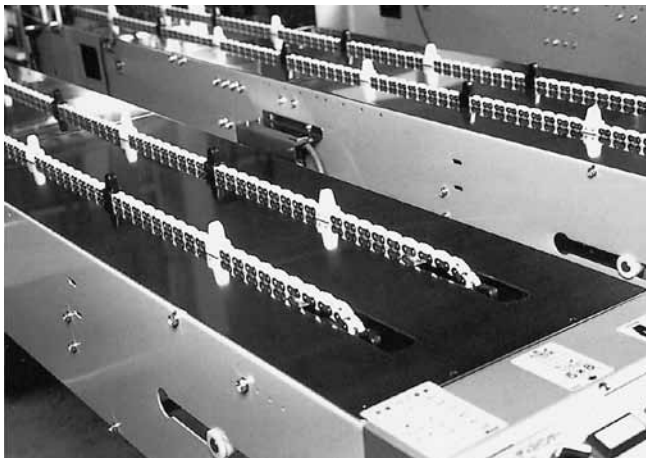

TYPE PN & PS

UNIT Upper:inch  
Beneath:mm

OCM Chain No.	Pitch P	Roller Diam. D	Width between L.P. W	Link Plate			Pin Diam. d	Pin		Average Tensile Strength Lb/kgf	Allowable Load Lb/kgf	Approx Weight Lb/ft kg/m
				H	T1	T2		L	L1			
OCM 15PS-PN	0.188	0.098	0.094	0.173	0.055	0.022	0.064	0.291	0.185	106	15	0.037
	4.7625	2.48	2.38	4.4	1.40	0.57	1.62	7.4	4.7	48	7	0.056
OCM 25PS-PN	0.250	0.130	0.126	0.236	0.059	0.030	0.091	0.362	0.213	143	20	0.067
	6.35	3.30	3.2	6.0	1.5	0.75	2.30	9.2	5.4	65	9	0.10
OCM 35PS-PN	0.375	0.200	0.189	0.354	0.091	0.049	0.141	0.551	0.319	243	40	0.147
	9.525	5.08	4.8	9.0	2.3	1.25	3.58	14.0	8.1	110	18	0.22
OCM 40PS-PN	0.500	0.312	0.313	0.472	0.062	0.059	0.156	0.654	0.382	551	93	0.213
	12.70	7.92	7.95	12.0	1.6	1.5	3.96	16.6	9.7	250	42	0.32
OCM 50PS-PN	0.625	0.400	0.376	0.591	0.094	0.079	0.200	0.839	0.496	794	159	0.400
	15.875	10.16	9.55	15.0	2.4	2.00	5.08	21.3	12.6	360	72	0.60
OCM 60PS-PN	0.750	0.469	0.500	0.709	0.126	0.094	0.234	1.075	0.606	1,257	207	0.574
	19.05	11.91	12.70	18.0	3.2	2.40	5.95	27.3	15.4	570	94	0.86

Material:

	Link plate	Pin	Roller Link
PN	Carbon steel Nickel plated	Alloy steel Nickel plated	Plastic
PS	Stainless steel SUS 304	Stainless steel SUS 304	Plastic

# PLAMATE CHAIN WITH ATTACHMENT

Chain can operate on ANSI standard sprockets.

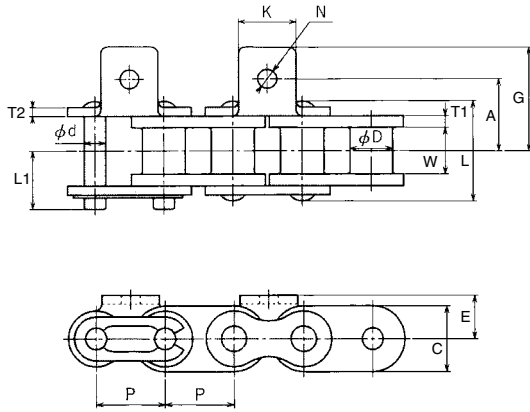

TYPE A-1

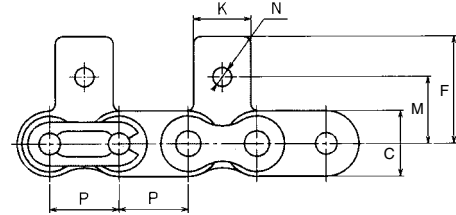
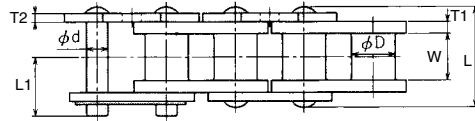

TYPE SA-1

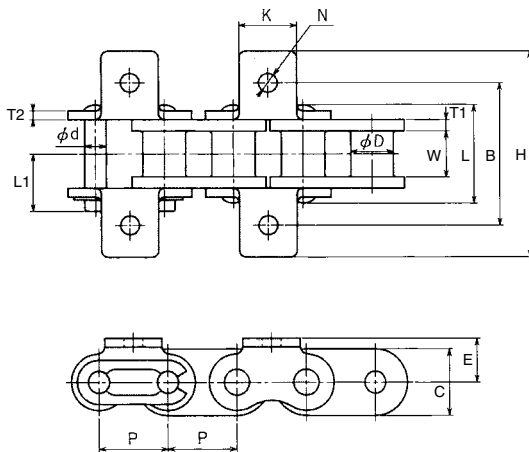

TYPE K-1

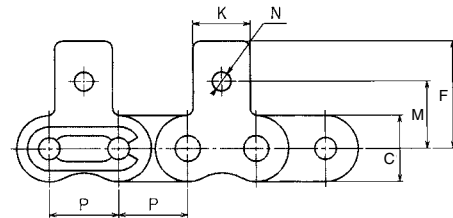
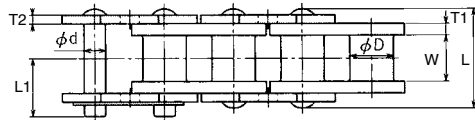

TYPE SK-1

UNIT Upper:inch  
Beneath:mm

OCM Chain No.	A TYPE					K TYPE		SA SK TYPE		Additional Weight per one att Lb/kg	
	K	N	A	E	G	B	H	M	F	A. SA	K. SK
OCM 25PS-PN	0.22 5.6	0.134 3.4	0.309 7.85	0.187 4.75	0.417 10.6	0.618 15.7	0.835 21.2	0.313 7.95	0.459 11.65	0.0007 0.0003	0.0013 0.0006
OCM 35PS-PN	0.311 7.9	0.134 3.4	0.411 10.45	0.25 6.35	0.545 13.85	0.823 20.9	1.091 27.7	0.374 9.5	0.579 14.7	0.0018 0.0008	0.0035 0.0016
OCM 40PS-PN	0.374 9.5	0.142 3.6	0.5 12.7	0.315 8	0.691 17.55	1 25.4	1.382 35.1	0.5 12.7	0.75 19.05	0.0022 0.001	0.0044 0.002
OCM 50PS-PN	0.5 12.7	0.205 5.2	0.638 16.2	0.406 10.3	0.921 23.4	1.276 32.4	1.843 46.8	0.628 15.95	0.994 25.25	0.0088 0.004	0.0176 0.008
OCM 60PS-PN	0.626 15.9	0.205 5.2	0.776 19.7	0.469 11.9	1.12 28.45	1.551 39.4	2.24 56.9	0.721 18.3	1.155 29.33	0.0154 0.007	0.0309 0.014

Note: Offset is not available. Use even number of pitches.  
Attachment is placed only on outside link.



# PLACURVE CHAIN

Placurve chain, made of plastic and stainless steel pin, can sideflex.  
 No lubrication, light in weight, clean and less noise.  
 Suitable for conveying bottles, paper bags, small products, food processing.  
 Chain can operate on ANSI standard sprockets.  
 Operatable temperature: -10°C~70°C  
 Chain speed should be less than 60M/min.  
 Material: Polyacetal  
 PC40S-20 has no wing and is for straight line running.

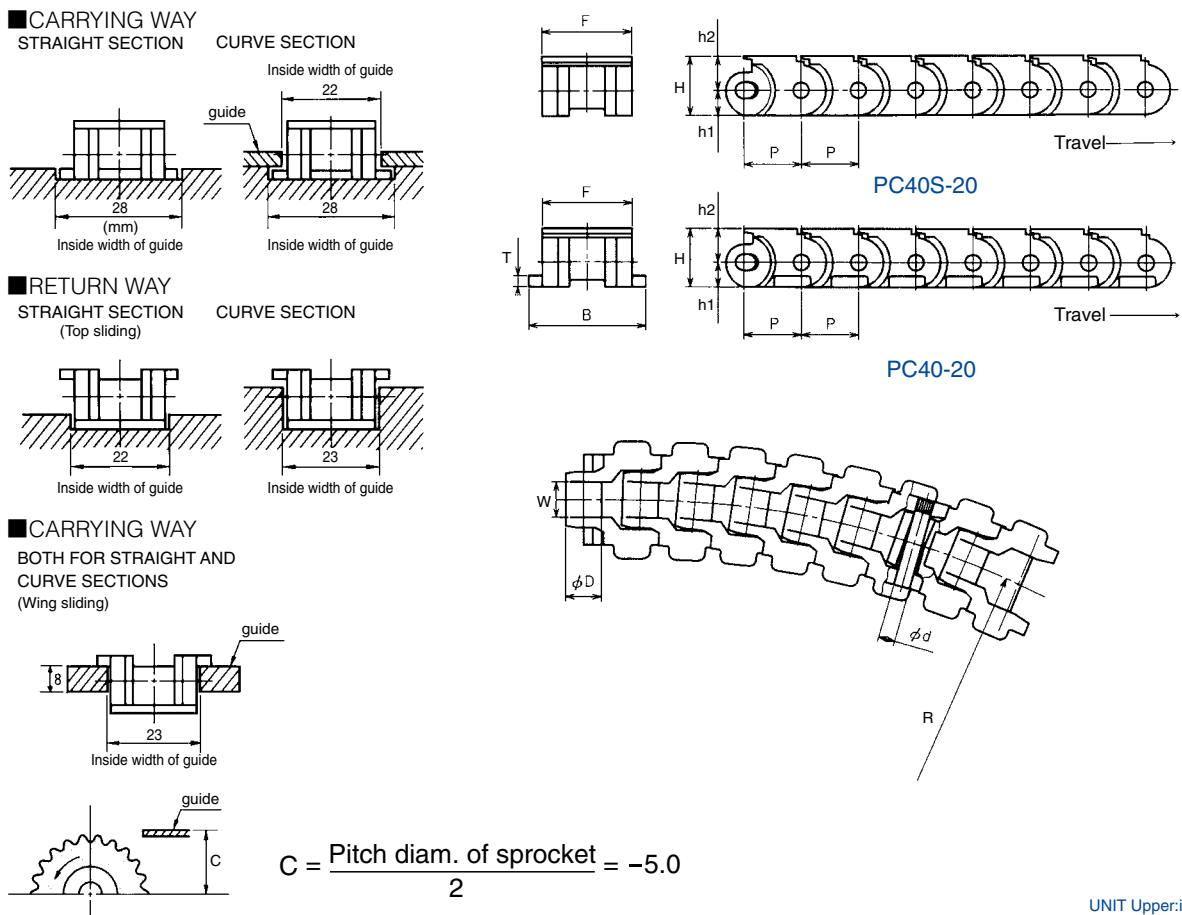
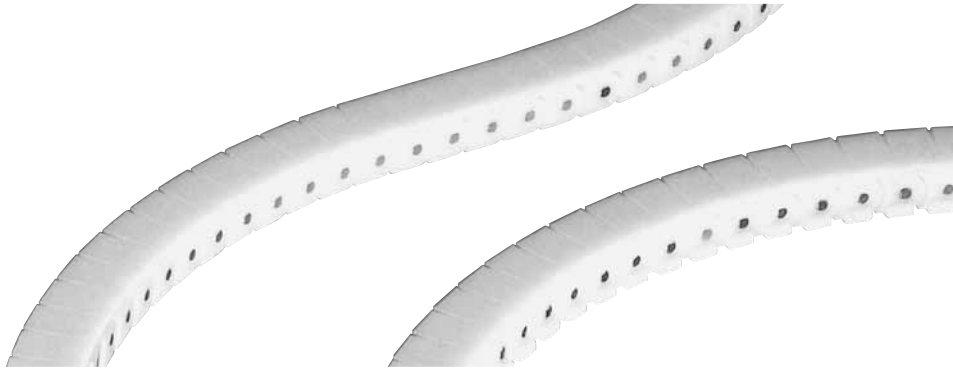

UNIT Upper:inch  
 Beneath:mm

OCM Chain No.	Pitch	Roller Diam.	Width between L.P.	Link Plate			Pin Diam.	Link Plate			Min Sideflex Radius	Max Working Load	Approx Weight
	P	D	W	h1	h2	H	d	F	T	B	R	Lb/kgf	kg/m
PC40-20	0.5	0.312	0.313	0.217	0.295	0.512	0.141	0.787	0.098	1.024	7.874	105.821	0.229
	12.7	7.92	7.95	5.5	7.5	13	3.58	20	2.5	26	200	48	0.34
PC40S-20	0.5	0.312	0.313	0.217	0.295	0.512	0.141	0.787	-	-	(200)	105.821	0.223
	12.7	7.92	7.95	5.5	7.5	13	3.58	20	-	-	-	48	0.33

# STRAIGHT RUNNING PLASTIC CHAIN

PD chain, made of polyacetal white and 18-8 stainless steel pin, is straight running chain. The chain can operate on standard ANSI sprockets. Operating temperature is -10°C~70°C. Chain speed should be less than 60M/min.

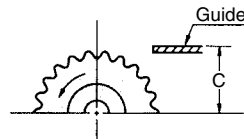
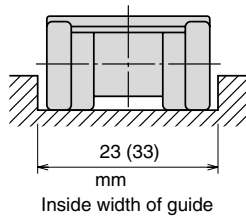
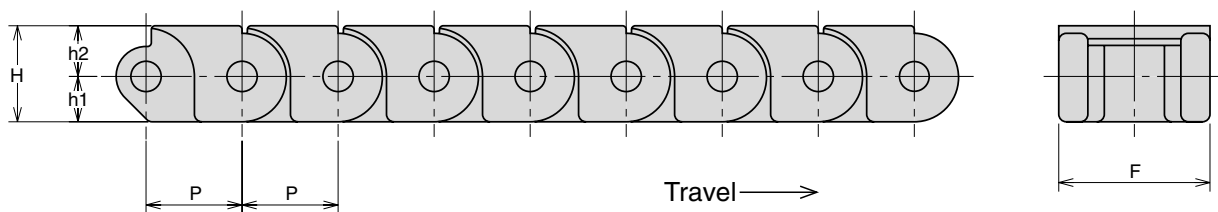
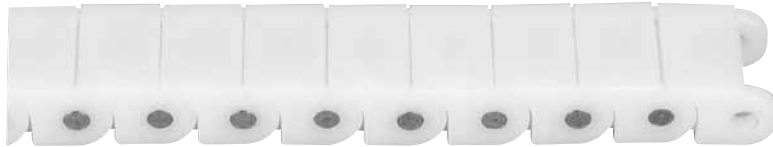

$$C = \frac{\text{Sprocket pitch diameter}}{2} = \frac{-6.0}{(8.0)}$$

UNIT Upper:inch  
Beneath:mm

OCM Chain No.	Pitch	Roller Diam.	Width between L.P.	Link Plate			Pin Diam.	F	Max Working Load Lb/kgf	Approx Weight Lb/ft kg/m
	P	D	W	h1	h2	H	d			
PD40-20	0.5	0.312	0.313	0.236	0.264	0.5	0.156	0.787	99	0.249
	12.7	7.92	7.95	6	6.7	12.7	3.96	20	45	0.37
PD60-30	0.75	0.469	0.5	0.335	0.346	0.681	0.235	1.181	198	0.531
	19.05	11.91	12.7	8.5	8.8	17.3	5.98	30	90	0.79

# PLALINK CHAIN

Stainless or steel outside link plates are molded together with plastic. It looks like outside link plates coated with plastic. Plalink Chain is developed to convey materials on the top of outside link plates.

As Plalink has the advantage of steel strength and plastic lower friction, it is suitable for conveying carton boxes, plastic pallets and products the surface of which should not be damaged. Materials to be conveyed can be accumulated and stopped momentarily.

It is especially suitable for applications where the strength of plastic is insufficient, the advantage of plastic smoothness and low noise are required.

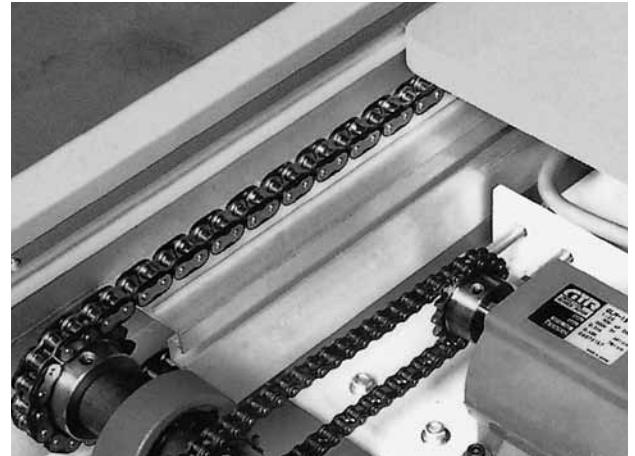

Type of Chain	Chain No.
Nickel Plated Chain: N	PLK40N
Stainless Steel Chain: SUS	PLK40SUS
Steel Selflube Chain: SER	PLK40N-SER

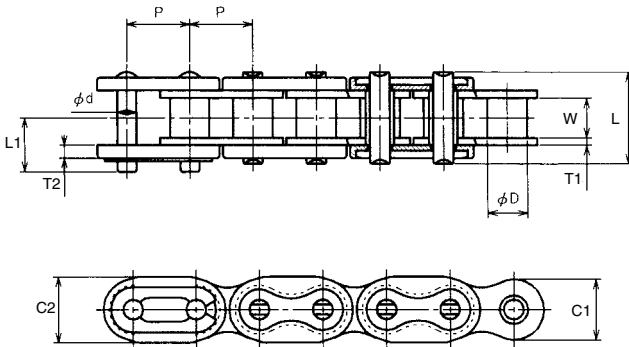

Usable temperature: -10°C to 70°C  
 Max chain speed: 30m/min and below.  
 Recommended 15m/min. and below  
 Sprockets: The minimum number of teeth is 13.  
 Plastic color: white and black.

UNIT:mm

OCM Chain No.			Pitch	Roller Diam.	Width between L.P.	Plate				Pin		
N TYPE	SUS TYPE	N-SER TYPE				P	D	W	C1	C2	T1	T2
OCM PLK40N	PLK40SUS	PLK40N-SER	12.7	7.92	7.95	12	13	1.5	2.6	3.96	18.3	10.9
OCM PLK50N	PLK50SUS	PLK50N-SER	15.875	10.16	9.55	15	16	2	3.1	5.08	22.6	13.3
OCM PLK60N	PLK60SUS	PLK60N-SER	19.05	11.91	12.7	18	19.2	2.4	3.8	5.95	28.2	16.2

OCM Chain No.	N.N-SER TYPE		OCM Chain No.	SUS TYPE		Max Load per Meter kg/m	Approx Weight kg/m
	Max Allowable Tension kN(kgf)			Max Allowable Tension kN(kgf)			
OCM PLK40N	2.26(230)		OCM PLK40SUS	0.44(45)		15	0.65
OCM PLK40N-SER	2.26(230)						
OCM PLK50N	3.53(360)		OCM PLK50SUS	0.74(75)		20	1.09
OCM PLK50N-SER	3.53(360)						
OCM PLK60N	5.10(520)		OCM PLK60SUS	1.03(105)		30	1.62
OCM PLK60N-SER	5.10(520)						

	PLK40	PLK50	PLK60
C(min)	8	10	11.5



If chain may interfere with the hub of sprockets, "C" dimension should be as shown above.

# CT TYPE CLIP TOP CHAIN

Plastic tops are snapped on extended pins of chain. The chain is enclosed with plastic tops. As there is no opening on plastic tops, it makes foreign objects difficult to go into between plastic tops.

Clip top chain is well suitable for applications where the strength of steel chain and the smooth surface of plastic are required, making it possible to convey heavy loads and prevent materials to be conveyed from damaging.

Carbon steel chain : CT-30-A

Nickel plated carbon steel chain : CT40N-U

Stainless steel chain (SUS304) : CT40SUS-E

Selflube steel chain : CT60SER-A

Type of plastic top :

A : Polyacetal (White) for general conveyance

U : Polyurethane (semi transparent) for slip-resistant conveyance

E : Electro conductive polyamide for preventing materials to be conveyed from electrification.

Usable temperature : -10°C to 70°C

(Polyurethane : -10°C to 50°C)

Max chain speed : 30m/min.

(Recommend : 15m/min and slower)

Minimum number of teeth of sprockets : 13

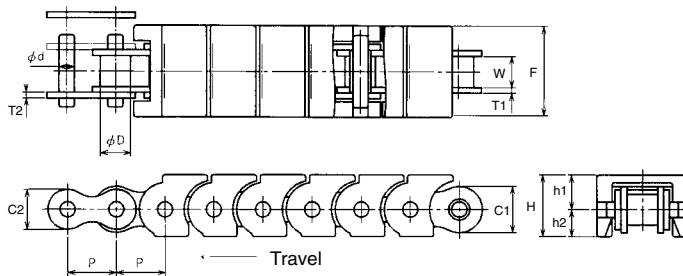
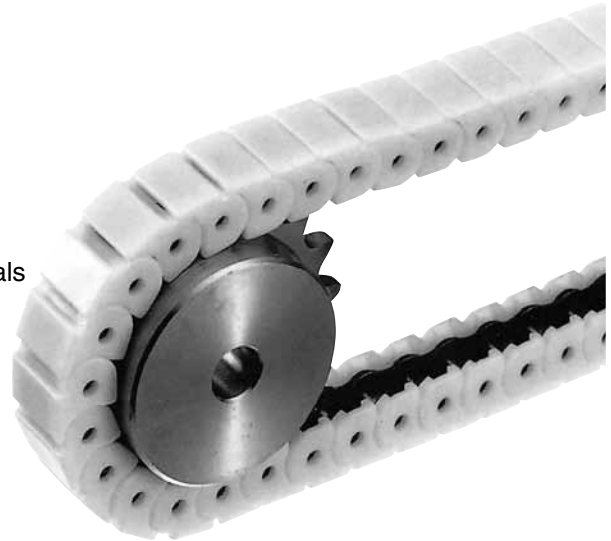

UNIT:mm

OCM Chain No.				Pitch P	Roller Diam. D	Width between L.P. W	Link Plate				Pin Diam. d	Clip Top			
Carbon Steel	N Type	SUS Type	SER Type				C1	C2	T1	T2		h1	h2	H	F
OCM CT30	CT30N			9.525	6.35	5.72	8.2	8.2	1.32	1	3.28	7.5	5.5	13	17.3
OCM CT40	CT40N	CT40SUS	CT40SER	12.7	7.92	7.95	12	10.4	1.5	1.5	3.96	9	7	16	23.5
OCM CT60	CT60N	CT60SUS	CT60SER	19.05	11.91	12.7	18	15.3	2.4	2.4	5.95	13.5	10.5	24	35.5

CARBON STEEL N. SER TYPE		SUS TYPE		Max Load per Pitch kg/m	Approx Weight kg/m
OCM Chain No.	Max Allowable Tension kN(kgf)	OCM Chain No.	Max Allowable Tension kN(kgf)		
OCM CT30 OCM CT30N	1.47(150)		-	3	0.55
OCM CT40 OCM CT40N OCM CT40SER	2.75(280)	CT40SUS	0.44(45)	5	0.85
OCM CT60 OCM CT60N OCM CT60SER	6.28(640)	CT60SUS	1.03(105)	10	1.95

	CT30	CT40	CT60
C(min)	7	8.5	12.5



If chain may interfere with the hub of sprockets, "C" dimension should be as shown above.

# DOUBLE PITCH PLALINK CHAIN

Plalink chain is made up of each outside link with plastic plate and carbon steel plate. Smoothness of plastic prevents products conveyed from being damaged. Carbon steel plates keep a steel strength.

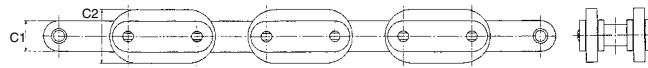
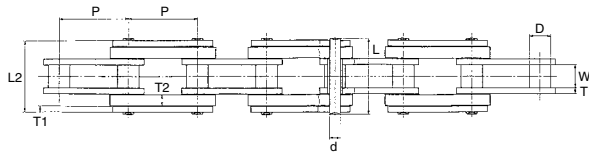

UNIT Upper:inch  
Beneath:mm

OCM Chain No.	Pitch	Roller Diam.	Width between L.P.	Link Plate				Pin Diam.	Pin		Max Allowable Tension	Max Load	Approx Weight
	P	D	W	C1	C2	T1	T2	d	L	L2	Lb/kgf	per ft/Lb per m/kgf	Lb/ft kg/m
PLKC2060H	1.5	0.469	0.5	0.677	1.181	0.126	0.236	0.234	1.634	1.543	767	16.79	1.076
	38.1	11.91	12.7	17.2	30	3.2	6	5.95	41.5	39.2	348	25	1.6

Chain with plastic roller (Polyacetal)

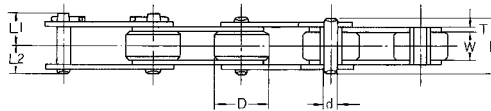
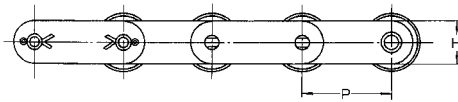

UNIT Upper:inch  
Beneath:mm

OCM Chain No.	Pitch	Roller Diam.	Width between L.P.	Link Plate		Pin Diam.	Pin			Average Tensile Strength	Allowable Load	Allowable Load of Roller	Weight
	P	D	W	H	T	d	L	L1	L2	Lb/kgf	Lb/kgf	Lb/kgf	Lb/ft kg/m
C2042	1.000	0.625	0.313	0.472	0.059	0.156	0.634	0.319	0.382	4.300	99	44	0.334
	25.40	15.88	7.95	12.0	1.5	3.96	16.1	8.1	9.7	1.950	45	20	0.50
C2052	1.250	0.750	0.376	0.591	0.079	0.200	0.799	0.409	0.476	7.056	165	66	0.547
	31.75	19.05	9.55	15.0	2.0	5.08	20.3	10.4	12.1	3.200	75	30	0.82
C2062H	1.500	0.875	0.500	0.677	0.126	0.234	1.130	0.563	0.650	9.812	232	110	0.987
	38.10	22.23	12.7	17.2	3.2	5.95	28.7	14.3	16.5	4.450	105	50	1.48
C2082H	2.000	1.125	0.626	0.945	0.157	0.313	1.413	0.709	0.839	16.538	397	198	1.734
	50.80	28.58	15.9	24.0	4.0	7.94	35.9	18.0	21.3	7.500	180	90	2.60

Fish conveying chain with sharp pointed pin

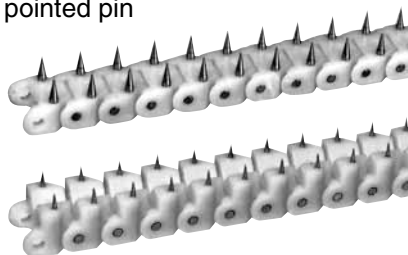

# BL SERIES LEAF CHAIN

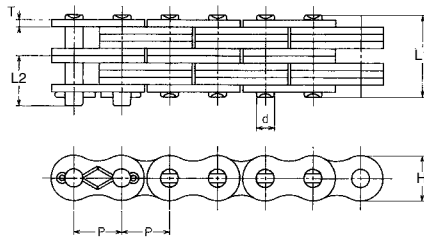
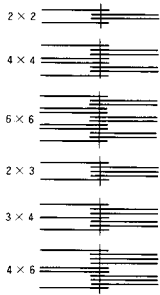

UNIT:mm

OCM Chain No.	Pitch P	Lacing	Link Plate		Pin Diam. d	Pin		Minimum Strength Tensile		Approx Weight kg/m	Hole Diam. (min)			
			H	T		L1	L2	kN	kgf					
BL422	12.7	2X2	12	2	5.08	10.4	7.5	24.51	2500	0.63	5.13			
BL423		2X3				12.6	8.5	24.51	2500			0.79		
BL434		3X4				16.8	10.6	36.76	3750				1.09	
BL444		4X4				18.9	11.7	49.02	5000					1.24
BL446		4X6				23.2	13.8	49.02	5000					
BL466	6X6	27.4	15.9	73.53	7500	1.58								
BL522	15.875	2X2	15	2.4	5.95	12.2	8.7	38.78	3950	0.95	6			
BL523		2X3				14.7	10	38.78	3950			1.17		
BL534		3X4				20.3	12.5	59.8	6100				1.63	
BL544		4X4				22.1	13.7	77.45	7900					1.85
BL546		4X6				27.2	16.2	77.45	7900					
BL566	6X6	32	18.6	116.18	11850	2.76								
BL622	19.05	2X2	18	3.2	7.94	16.4	11.8	63.73	6500	1.53	8.01			
BL623		2X3				19.7	13.4	63.73	6500			1.89		
BL634		3X4				26.3	16.8	95.59	9750				2.62	
BL644		4X4				29.8	18.5	127.45	13000					2.99
BL646		4X6				36.2	21.8	127.45	13000					
BL666	6X6	43.2	25.2	191.18	19500	4.45								
BL822	25.4	2X2	24	4	9.53	20.1	13.9	95.1	9700	2.6	9.6			
BL823		2X3				24.3	16	95.1	9700			3.24		
BL834		3X4				32.5	20.1	156.86	16000				4.5	
BL844		4X4				36.7	22.2	200	20400					5.14
BL846		4X6				45	26.4	200	20400					
BL866	6X6	53.2	30.5	285.29	29100	7.66								
BL1022	31.75	2X2	30	4.8	11.11	24	15.7	137.25	14000	3.89	11.19			
BL1023		2X3				28.9	18.1	137.25	14000			4.84		
BL1034		3X4				38.8	23.1	235.29	24000				6.73	
BL1044		4X4				43.8	25.6	274.51	28000					7.67
BL1046		4X6				53.6	30.5	274.51	28000					
BL1066	6X6	63.6	35.5	411.76	42000	11.5								
BL1222	38.1	2X2	36	5.6	12.7	27.8	19.2	176.47	18000	5.44	12.78			
BL1223		2X3				33.8	22.1	176.47	18000			6.78		
BL1234		3X4				45.3	27.9	284.31	29000				9.43	
BL1244		4X4				51.1	30.8	352.94	36000					10.8
BL1246		4X6				62.6	36.6	352.94	36000					
BL1266	6X6	74.3	42.5	529.41	54000	16.1								
BL1422	44.45	2X2	42	6.4	14.29	31.8	-	215.69	22000	7.22	14.36			
BL1423		2X3				38.4	-	215.69	22000			8.98		
BL1434		3X4				51.6	-	343.14	35000				12.5	
BL1444		4X4				58.2	-	431.37	44000					14.3
BL1446		4X6				71.4	-	431.37	44000					
BL1466	6X6	84.6	-	647.06	66000	21.3								
BL1622	50.8	2X2	48.2	7.2	17.45	35.8	-	323.53	33000	9.25	17.55			
BL1623		2X3				43.8	-	323.53	33000			11.5		
BL1634		3X4				58.6	-	517.65	52800				16	
BL1644		4X4				66.1	-	647.06	66000					18.3
BL1646		4X6				80.7	-	647.06	66000					
BL1666	6X6	96.4	-	970.59	99000	27.3								

# AL SERIES LEAF CHAIN

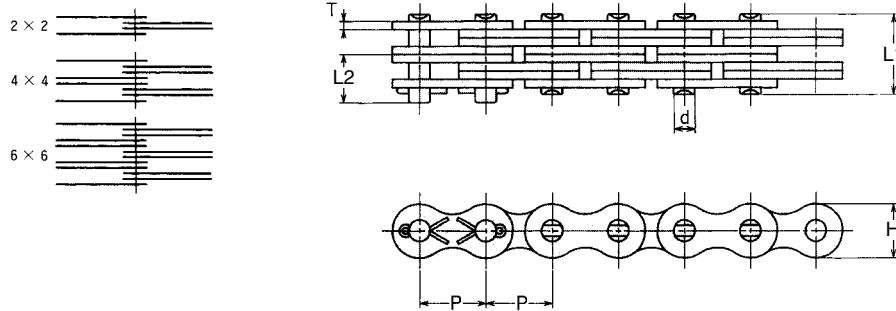

UNIT:mm

OCM Chain No.	Pitch P	Lacing	Link Plate		Pin Diam. d	Pin		Minimum Tensile Strength		Approx Weight kg/m	Hole Diam. (min)
			H	T		L1	L2	kN	kgf		
AL422	12.7	2X2	10.4	1.5	3.96	8.4	6.3	16.67	1700	0.38	4.01
AL444		4X4				14.8	9.5	33.33	3400	0.74	
AL466		6X6				21.2	12.7	50	5100	1.1	
AL522	15.875	2X2	13	2	5.08	10.4	7.5	27.75	2830	0.62	5.13
AL544		4X4				18.9	11.7	55.49	5660	1.22	
AL566		6X6				27.4	15.9	83.24	8490	1.81	
AL622	19.05	2X2	15.3	2.4	5.95	12.2	8.7	38.53	3930	0.87	6
AL644		4X4				22.1	13.7	77.06	7860	1.71	
AL666		6X6				32	18.6	115.59	11790	2.54	
AL822	25.4	2X2	20.8	3.2	7.94	16.4	11.8	68.14	6950	1.67	8.01
AL844		4X4				29.8	18.5	136.27	13900	3.3	
AL866		6X6				43.2	25.2	204.41	20850	4.92	
AL1022	31.75	2X2	26	4	9.53	19.5	13.9	100.98	10300	2.59	9.6
AL1044		4X4				36.7	22.2	201.96	20600	5.14	
AL1066		6X6				53.2	30.5	302.94	30900	7.68	
AL1222	38.1	2X2	31.2	4.8	11.11	24	15.7	137.25	14000	3.73	11.18
AL1244		4X4				43.8	25.6	274.51	28000	7.38	
AL1266		6X6				63.6	35.5	411.76	42000	11	
AL1444	44.45	4X4	36.2	5.6	12.7	51.1	30.8	362.75	37000	9.92	12.78
AL1466		6X6				74	42.5	544.12	55500	14.8	
AL1644		4X4				58.2	-	455.88	46500	13.1	
AL1666	50.8	6X6	41.6	6.4	14.29	84.5	-	683.82	69750	19.6	14.36

# OCM SMALL CONVEYOR CHAIN

## CIRCULAR CHAIN

The chain is an extra clearance chain to permit side flexing and twisting. It is designed for curved conveyor application. The chain is made of the same material to ANSI standard roller chain, and operate on ANSI standard sprockets.

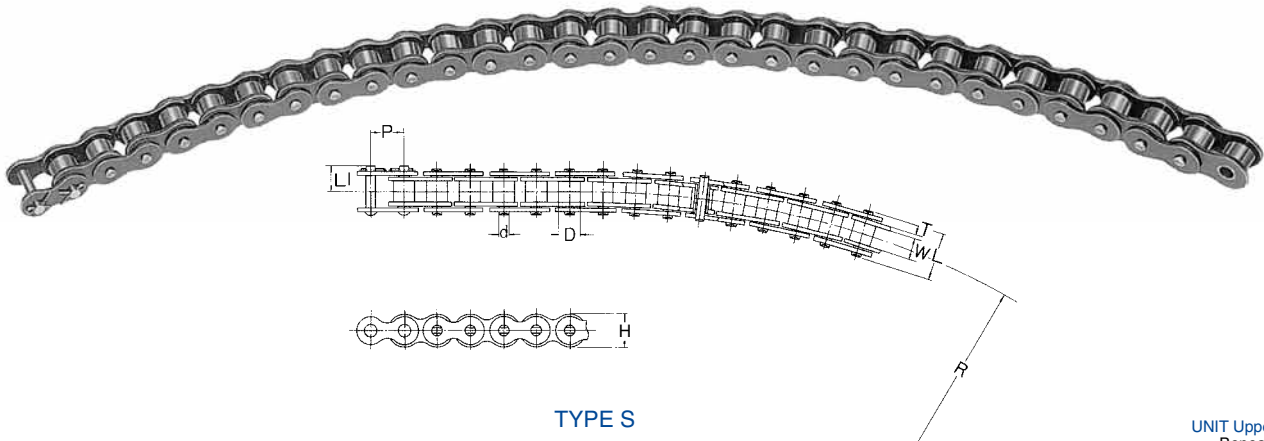

UNIT Upper:inch  
Beneath:mm

OCM Chain No.	Pitch	Roller Diam.	Width between L.P.	Link Plate		Pin Diam.	Pin		Min Radius of Side Bow
	P	D	W	H	T	d	L	L1	R
40C	0.500	0.312	0.313	0.472	0.059	0.127	0.669	0.394	13.78
	12.7	7.92	7.95	12	1.5	3.22	17	10	350
50C	0.625	0.4	0.376	0.591	0.079	0.165	0.843	0.5	15.748
	15.88	10.16	9.55	15	2	4.2	21.4	12.7	400
60C	0.750	0.469	0.5	0.709	0.094	0.2	1.039	0.591	21.654
	19.05	11.91	12.7	18	2.4	5.08	26.4	15	550
80C	1.000	0.625	0.626	0.945	0.126	0.234	1.378	0.78	29.528
	25.4	15.88	15.9	24	3.2	5.95	35	19.8	750

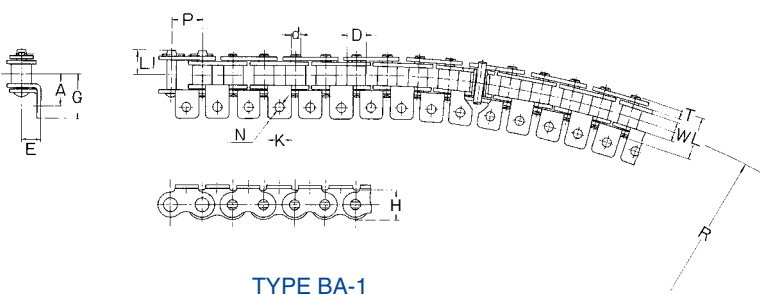

UNIT Upper:inch  
Beneath:mm

OCM Chain No.	(BA-BK)Attachment					Average Tensile Strength	Approx Weight	Additional Weight Per Attachment (kgf)	
	K	N	A	E	G			Lb/kg BA-1	Lb/kg BK-1
40C	0.374	0.142	0.5	0.315	0.691	2425	0.42	0.002	0.004
	9.5	3.6	12.7	8	17.55	1100	0.62	0.001	0.002
50C	0.5	0.205	0.626	0.406	0.909	4189	0.68	0.009	0.018
	12.7	5.2	15.9	10.3	23.1	1900	1.01	0.004	0.008
60C	0.626	0.205	0.752	0.469	1.094	6063	1.02	0.015	0.031
	15.9	5.2	19.1	11.9	27.8	2750	1.52	0.007	0.014
80C	0.752	0.268	1	0.626	1.276	7496	1.65	0.024	0.049
	19.1	6.8	25.4	15.9	32.4	3400	2.46	0.011	0.022



# DOUBLE PITCH CONVEYOR CHAIN

This conveyor is midway between precision roller chain and FM, FE type conveyors.

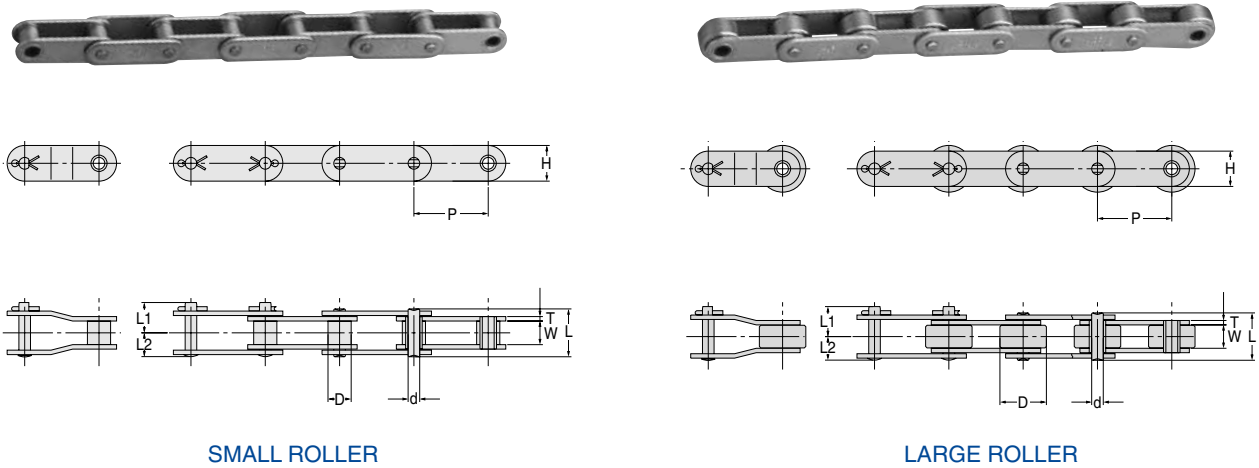

SMALL ROLLER

LARGE ROLLER

SMALL ROLLER

UNIT Upper:inch  
Beneath:mm

OCM Chain No.	ANSI No.	Pitch	Roller Diam.	Width between L.P.		Link Plate		Pin Diam.	Pin			Average Tensile Strength	Max. Working Load	Approx Weight
		P	D	W	H	T	d	L	L1	L2	Lb/kgf	Lb/kgf	Lb/ft kg/m	
C2040	C2040	1.000	0.312	0.313	0.472	0.059	0.156	0.634	0.382	0.319	3638	595	0.34	
		25.4	7.92	7.95	12	1.5	3.96	16.1	9.7	8.1	1650	270	0.51	
C2050	C2050	1.250	0.4	0.376	0.591	0.079	0.2	0.799	0.476	0.409	5952	970	0.58	
		31.75	10.16	9.55	15	2	5.08	20.3	12.1	10.4	2700	440	0.87	
C2060H	C2060H	1.500	0.469	0.5	0.677	0.126	0.234	1.13	0.65	0.563	8598	1323	1.01	
		38.1	11.91	12.7	17.2	3.2	5.95	28.7	16.5	14.3	3900	600	1.51	
C2080H	C2080H	2.000	0.625	0.626	0.945	0.157	0.313	1.413	0.839	0.709	14771	2205	1.79	
		50.8	15.88	15.9	24	4	7.94	35.9	21.3	18	6700	1000	2.66	
C2100H	C2100H	2.500	0.75	0.754	1.142	0.189	0.375	1.697	0.992	0.85	23149	3307	2.68	
		63.5	19.05	19.15	29	4.8	9.53	43.1	25.2	21.6	10500	1500	3.99	
C2120H	C2120H	3.000	0.875	1.006	1.339	0.22	0.437	2.11	1.185	1.055	33951	4630	3.76	
		76.2	22.23	25.55	34	5.6	11.11	53.6	30.1	26.8	15400	2100	5.6	
C2160H	C2160H	4.000	1.125	1.256	1.85	0.283	0.563	2.673	1.52	1.339	49604	7937	6.38	
		101.6	28.58	31.9	47	7.2	14.29	67.9	38.6	34	22500	3600	9.5	

LARGE ROLLER

UNIT Upper:inch  
Beneath:mm

OCM Chain No.	ANSI No.	Pitch	Roller Diam.	Width between L.P.		Link Plate		Pin Diam.	Pin			Average Tensile Strength	Max. Working Load	Approx Weight
		P	D	W	H	T	d	L	L1	L2	Lb/kgf	Lb/kgf	Lb/ft kg/m	
C2042	C2042	1.000	0.625	0.313	0.472	0.059	0.156	0.634	0.382	0.319	3638	595	0.58	
		25.4	15.88	7.95	12	1.5	3.96	16.1	9.7	8.1	1650	270	0.87	
C2052	C2052	1.250	0.75	0.376	0.591	0.079	0.2	0.799	0.476	0.409	5952	970	0.91	
		31.75	19.05	9.55	15	2	5.08	20.3	12.1	10.4	2700	440	1.35	
C2062H	C2062H	1.500	0.875	0.5	0.677	0.126	0.234	1.13	0.65	0.563	8598	1323	1.47	
		38.1	22.23	12.7	17.2	3.2	5.95	28.7	16.5	14.3	3900	600	2.19	
C2082H	C2082H	2.000	1.125	0.626	0.945	0.157	0.313	1.413	0.839	0.709	14771	2205	2.47	
		50.8	28.58	15.9	24	4	7.94	35.9	21.3	18	6700	1000	3.68	
C2102H	C2102H	2.500	1.563	0.754	1.142	0.189	0.375	1.697	0.992	0.85	23149	3307	4.23	
		63.5	39.69	19.15	29	4.8	9.53	43.1	25.2	21.6	10500	1500	6.3	
C2122H	C2122H	3.000	1.75	1.006	1.339	0.22	0.437	2.11	1.185	1.055	33951	4630	6.32	
		76.2	44.45	25.55	34	5.6	11.11	53.6	30.1	26.8	15400	2100	9.4	
C2162H	C2162H	4.000	2.25	1.256	1.85	0.283	0.563	2.673	1.52	1.339	49604	7937	9.74	
		101.6	57.15	31.9	47	7.2	14.29	67.9	38.6	34	22500	3600	14.5	

# ROLLER CHAIN WITH ATTACHMENT



TYPE A-1

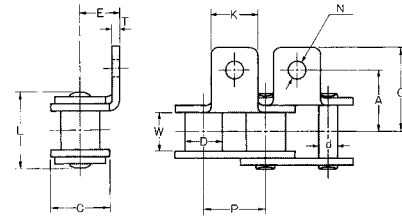

TYPE K-1

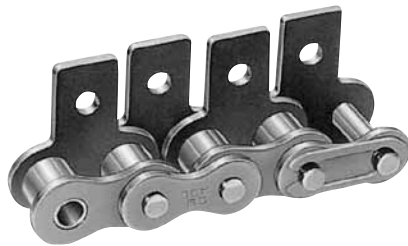
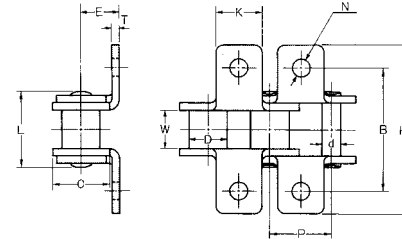

TYPE SA-1

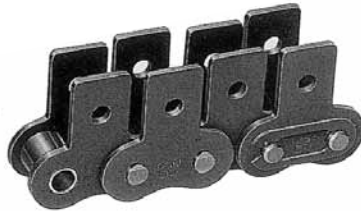
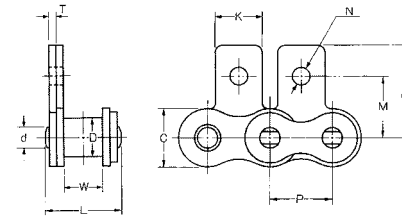

TYPE SK-1

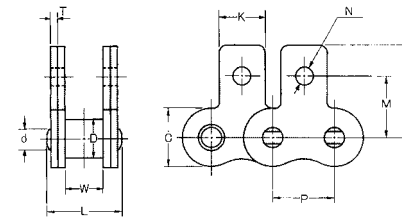

UNIT Upper:inch  
Beneath:mm

OCM Chain No.	Pitch P	Roller Diam. D	Width between L.P. W	Link Plate		Pin		(BA-BK-SA-SK) Attachment										Additional Weight Per Attachment Lb/kg	
								(2A)					(2G)						
								C	T	d	L	(L)	K	N	A	E	G		
25	0.250	0.130	0.126	0.230	0.030	0.091	0.295	0.307	0.220	0.134	0.281	0.187	0.390	0.563	0.780	0.313	0.459	0.0007	0.0013
	6.35	3.3	3.2	5.85	0.75	2.3	7.5	7.8	5.6	3.4	7.15	4.75	9.9	14.3	19.8	7.95	11.65	0.0003	0.0006
35	0.375	0.200	0.189	0.354	0.049	0.141	0.461	0.465	0.311	0.110	0.374	0.250	0.508	0.748	1.016	0.374	0.579	0.0018	0.0035
	9.525	5.08	4.8	9	1.25	3.58	11.7	11.8	7.9	3.4	9.5	6.35	12.9	19	25.8	9.5	14.7	0.0008	0.0016
40	0.500	0.312	0.313	0.472	0.059	0.156	0.634	0.654	0.374	0.142	0.500	0.315	0.691	1.000	1.382	0.500	0.750	0.0022	0.0044
	12.7	7.92	7.95	12	1.5	3.96	16.1	16.6	9.5	3.6	12.7	8	17.55	25.4	35.1	12.7	19.05	0.001	0.002
50	0.625	0.400	0.376	0.591	0.079	0.200	0.799	0.819	0.500	0.205	0.626	0.406	0.909	1.252	1.819	0.628	0.994	0.0088	0.0176
	15.875	10.16	9.55	15	2	5.08	20.3	20.8	12.7	5.2	15.9	10.3	23.1	31.8	46.2	15.95	25.25	0.004	0.008
60	0.750	0.469	0.500	0.709	0.094	0.234	1.000	1.020	0.626	0.205	0.750	0.469	1.094	1.500	2.189	0.720	1.155	0.0154	0.0309
	19.05	11.91	12.7	18	2.4	5.95	25.4	25.9	15.9	5.2	19.05	11.9	27.8	38.1	55.6	18.3	29.33	0.007	0.014
80	1.000	0.625	0.626	0.945	0.126	0.313	1.287	1.299	0.752	0.268	1.000	0.626	1.276	2.000	2.551	0.969	1.366	0.0243	0.0485
	25.4	15.88	15.9	24	3.2	7.94	32.7	33	19.1	6.8	25.4	15.9	32.4	50.8	64.8	24.6	34.7	0.011	0.022
100	1.250	0.750	0.754	1.181	0.157	0.375	1.697	1.701	1.000	0.346	1.250	0.780	1.719	2.500	3.437	1.252	1.705	0.0507	0.1014
	31.75	19.05	19.15	30	4	9.53	43.1	43.2	25.4	8.8	31.75	19.8	43.65	63.5	87.3	31.8	43.3	0.023	0.046
120	1.500	0.875	1.006	1.417	0.189	0.437	2.106	2.114	1.126	0.413	1.500	0.906	2.136	3.000	4.272	1.437	2.031	0.0838	0.1676
	38.1	22.23	25.55	36	4.8	11.11	53.5	53.7	28.6	10.5	38.1	23	54.25	76.2	108.5	36.5	51.6	0.038	0.076
140	1.750	1.000	1.004	1.654	0.220	0.500	2.319	2.323	1.374	0.472	1.750	1.126	2.421	3.500	4.843	1.750	2.441	0.1455	0.291
	44.45	25.4	25.5	42	5.6	12.7	58.9	59	34.9	12	44.45	28.6	61.5	88.9	123	44.45	62	0.066	0.132
160	2.000	1.125	1.256	1.850	0.252	0.563	2.720	2.728	1.500	0.551	2.000	1.252	2.811	4.000	5.622	2.000	2.750	0.172	0.3439
	50.8	28.58	31.9	47	6.4	14.29	69.1	69.3	38.1	14	50.8	31.8	71.4	101.6	142.8	50.8	69.85	0.078	0.156

Stainless attachment chain is available.  
(L) indicates the dimension of stainless steel chain.

# DOUBLE PITCH CHAIN WITH ATTACHMENT

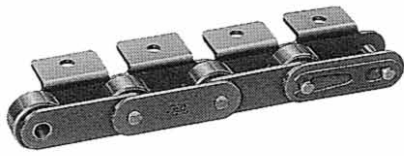

TYPE A-1.2

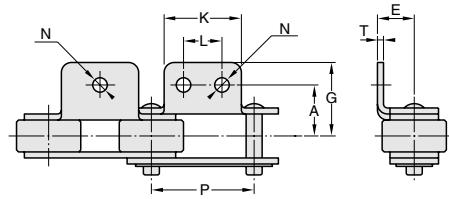

TYPE K-1.2

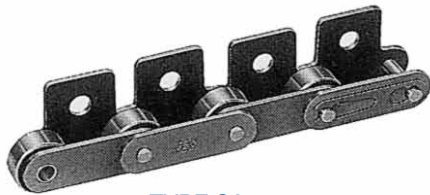
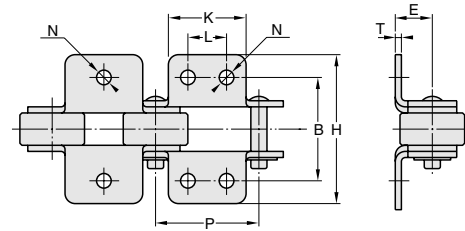

TYPE SA-1.2

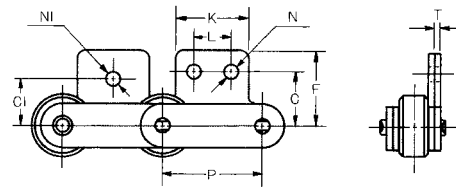

TYPE SK-1.2

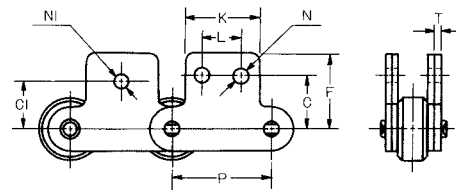

UNIT Upper:inch  
Beneath:mm

OCM Chain No.	Pitch P	Link Plate T	(BA·BK·SA·SK) Attachment												Additional Weight Per Attachment Lb/kg	
			(2A)						(2G)							
			K	N	L	A	E	G	B	H	C	F	C1	N1	BA·SA	BK·SK
C2040-C2042	1.000	0.059	0.752	0.142	0.374	0.500	0.358	0.780	1.000	1.559	0.531	0.807	0.437	0.205	0.007	0.013
	25.4	1.5	19.1	3.6	9.5	12.7	9.1	19.8	25.4	39.6	13.5	20.5	11.1	5.2	0.003	0.006
C2050-C2052	1.250	0.079	0.937	0.205	0.469	0.626	0.437	0.965	1.252	1.929	0.626	0.984	0.563	0.268	0.013	0.026
	31.75	2	23.8	5.2	11.9	15.9	11.1	24.5	31.8	49	15.9	25	14.3	6.8	0.006	0.012
C2060H-C2062H	1.500	0.126	1.126	0.205	0.563	0.843	0.579	1.240	1.685	2.480	0.752	1.295	0.689	0.346	0.037	0.075
	38.1	3.2	28.6	5.2	14.3	21.4	14.7	31.5	42.8	63	19.1	32.9	17.5	8.8	0.017	0.034
C2080H-C2082H	2.000	0.157	1.500	0.268	0.752	1.094	0.752	1.602	2.189	3.205	1.000	1.713	0.874	0.413	0.082	0.163
	50.8	4	38.1	6.8	19.1	27.8	19.1	40.7	55.6	81.4	25.4	43.5	22.2	10.5	0.037	0.074
C2100H-C2102H	2.500	0.189	1.874	0.346	0.937	1.311	0.921	1.965	2.622	3.929	1.252	2.106	1.126	0.551	0.154	0.309
	63.5	4.8	47.6	8.8	23.8	33.3	23.4	49.9	66.6	99.8	31.8	53.5	28.6	14	0.07	0.14
C2120H-C2122H	3.000	0.220	2.252	0.413	1.126	1.563	1.094	2.390	3.126	4.780	1.469	2.480	1.311	0.630	0.254	0.507
	76.2	5.6	57.2	10.5	28.6	39.7	27.8	60.7	79.4	121.4	37.3	63	33.3	16	0.115	0.23
C2160H-C2162H	4.000	0.283	3.000	0.551	1.500	2.063	1.437	3.028	4.126	6.055	2.000	3.012	1.752	0.827	0.5	1.001
	101.6	7.2	76.2	14	38.1	52.4	36.5	76.9	104.8	153.8	50.8	76.5	44.5	21	0.227	0.454

Stainless attachment chain is available.

# ROLLER CHAIN WITH EXTEND PIN



D-3

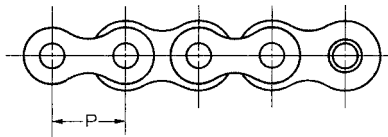
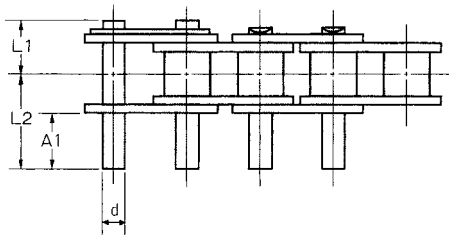

D-3 EXTEND PIN



D-1

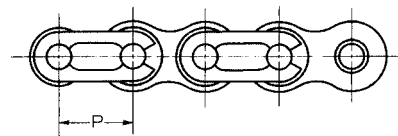
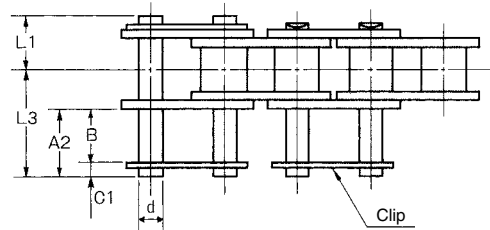

EXTEND PIN WITH SPRING CLIP

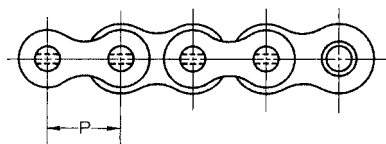
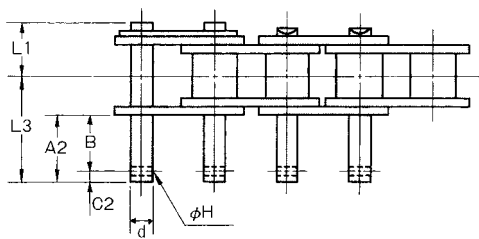

EXTEND PIN WITH COTTER HOLE

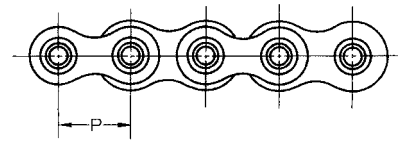
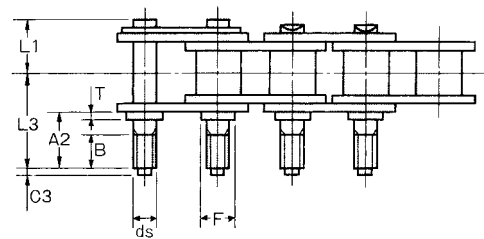

THREADED EXTEND PIN

UNIT Upper:inch  
Beneath:mm

OCM Chain No.	Pitch		Pin Diam.		Link Plate			Pin						L3,A2,B
	P		d	ds	F	T	φ H	L1	L2	A1	C1	C2	C3	
35	0.375	0.141	M3	0.180	0.047	0.047	0.264	0.575	0.374	0.067	0.055	0.039	1.0	
	9.525	3.58												6.7
40	0.500	0.156	M4	0.201	0.059	0.063	0.382	0.657	0.374	0.091	0.083	0.039	1.0	
	12.7	3.96												9.7
50	0.625	0.200	M5	0.238	0.079	0.063	0.476	0.827	0.469	0.122	0.091	0.039	1.0	
	15.875	5.08												12.1
60	0.750	0.234	M6	0.319	0.094	0.079	0.579	1.014	0.563	0.122	0.102	0.059	1.5	
	19.05	5.95												14.7
80	1.000	0.313	M8	0.381	0.126	0.102	0.776	1.331	0.752	0.154	0.142	0.059	1.5	
	25.4	7.94												19.7
100	1.250	0.375	M10	0.443	0.157	0.122	0.925	1.642	0.937	-	0.157	0.079	2.0	
	31.75	9.53												23.5
120	1.500	0.437	M12	0.520	0.189	0.122	1.118	2.020	1.126	-	0.157	0.079	2.0	
	38.1	11.11												28.4

Spring clip is not available for 100 and above.

# DOUBLE PITCH CHAIN WITH EXTEND PIN



D-3

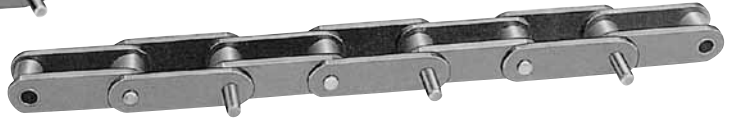

D-1

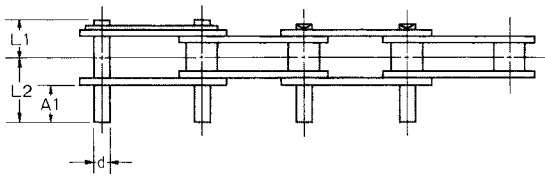

D-3 EXTEND PIN

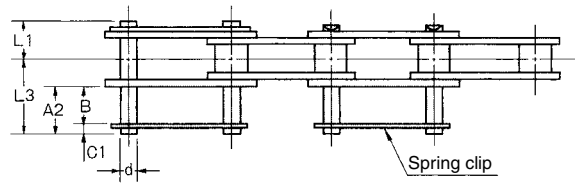

EXTEND PIN WITH SPRING CLIP

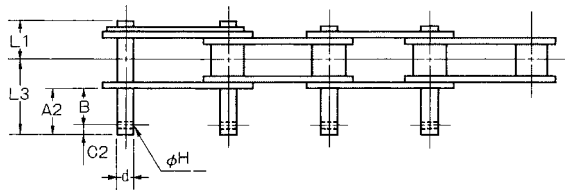

EXTEND PIN WITH COTTER HOLE

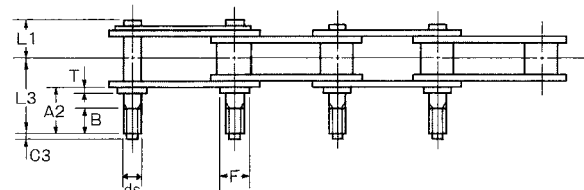

THREADED EXTEND PIN

UNIT Upper:inch  
Beneath:mm

OCM Chain No.	Pitch P	Pin Diam. d	Link Plate				Pin							L3,A2,B
			ds	F	T	φ H	L1	L2	A1	C1	C2	C3		
C2040-C2042	1.000	0.156	M4	0.201	0.059	0.063	0.382	0.661	0.374	0.091	0.083	0.039	Specify either A2 and B or L3 and B	
	25.4	3.96		5.11	1.5	1.6	9.7	16.8	9.5	2.3	2.1	1.0		
C2050-C2052	1.250	0.200	M5	0.238	0.079	0.063	0.476	0.831	0.469	0.122	0.091	0.039		
	31.75	5.08		6.04	2	1.6	12.1	21.1	11.9	3.1	2.3	1.0		
C2060H-C2062H	1.500	0.234	M6	0.319	0.126	0.079	0.650	1.083	0.563	0.122	0.102	0.059		
	38.1	5.95		8.09	3.2	2	16.5	27.5	14.3	3.1	2.6	1.5		
C2080H-C2082H	2.000	0.313	M8	0.381	0.157	0.102	0.839	1.398	0.752	-	0.142	0.059		
	50.8	7.94		9.68	4	2.6	21.3	35.5	19.1	-	3.6	1.5		
C2100H-C2102H	2.500	0.375	M10	0.443	0.189	0.122	0.992	1.709	0.937	-	0.157	0.079		
	63.5	9.53		11.26	4.8	3.1	25.2	43.4	23.8	-	4.0	2.0		

Spring clip is not available for C2080H and above.

# WIDE CONTOUR ATTACHMENT

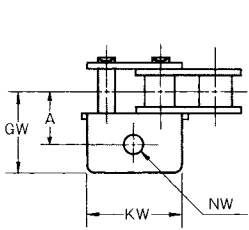

TYPE WA-1

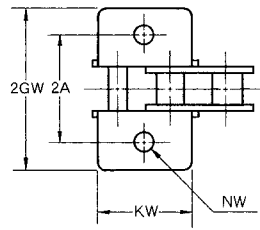

TYPE WK-1

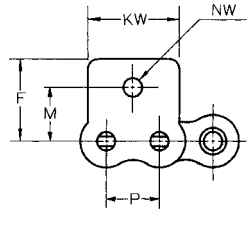

TYPE WSA-1

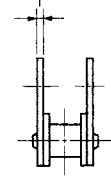
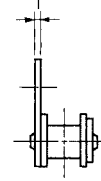

TYPE WSK-1

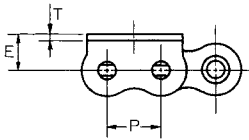

TYPE WA-2

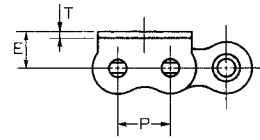

TYPE WK-2

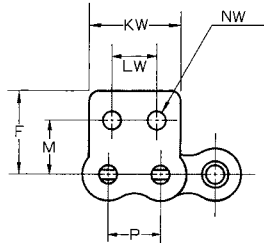

TYPE WSA-2

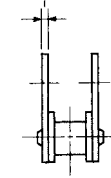
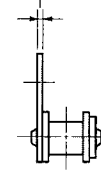

TYPE WSK-2

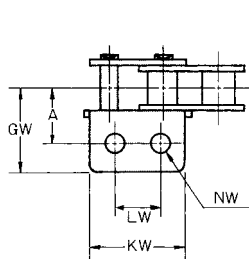

TYPE WA-2

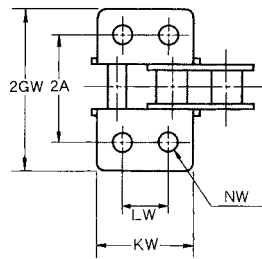

TYPE WK-2

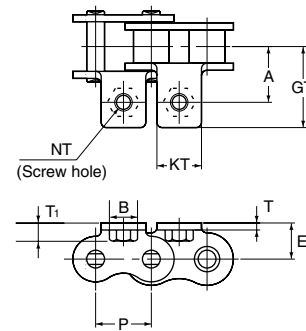

TYPE PA-1

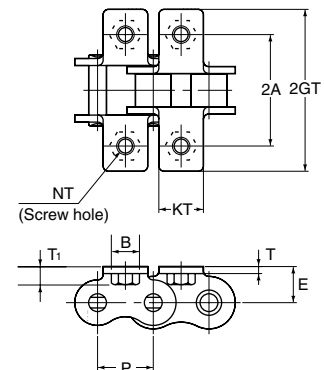

TYPE PK-1

UNIT Upper:inch  
Beneath:mm

OCM Chain No.	Pitch P															Link Plate T	Additional Weight Per Attachment Lb/kgf			
		KW	KT	LW	NW	NT	A	E	GW	GT	B	T1	M	F	TA		TK	WA, WSA	WK, WSK	
40	0.500	0.906	0.374	0.374	0.177		0.500	0.315	0.691	0.691	0.319	0.150	0.500	0.689	0.059	0.002	0.004	0.009	0.018	
	12.7	23	9.5	9.5	4.5	M4	12.7	8	17.55	17.55	8.1	3.8	12.7	17.5	1.5	0.001	0.002	0.004	0.008	
50	0.625	1.134	0.500	0.469	0.217		0.626	0.406	0.909	0.909	0.362	0.201	0.626	0.909	0.079	0.009	0.018	0.015	0.031	
	15.875	28.8	12.7	11.9	5.5	M5	15.9	10.3	23.1	23.1	9.2	5.1	15.9	23.1	2	0.004	0.008	0.007	0.014	
60	0.750	1.362	0.626	0.563	0.260		0.750	0.469	1.094	1.094	0.453	0.287	0.720	1.057	0.094	0.015	0.031	0.029	0.057	
	19.05	34.6	15.9	14.3	6.6	M6	19.05	11.9	27.8	27.8	11.5	7.3	18.3	26.85	2.4	0.007	0.014	0.013	0.026	
80	1.000	1.815	0.752	0.752	0.354		1.000	0.626	1.402	1.276	0.591	0.339	0.969	1.366	0.126	0.024	0.049	0.062	0.123	
	25.4	46.1	19.1	19.1	9	M8	25.4	15.9	35.6	32.4	15	8.6	24.6	34.7	3.2	0.011	0.022	0.028	0.056	

# THREADED HOLE ATTACHMENT

Sunk attachment is suitable where attachment wears quickly from sliding.

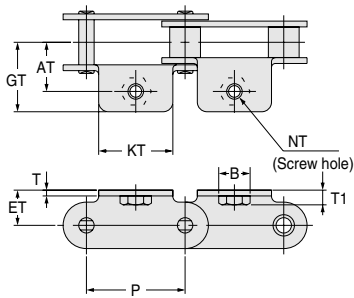

TYPE PA-1

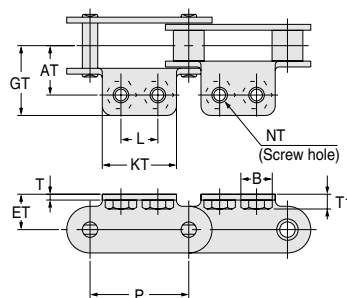

TYPE PA-2

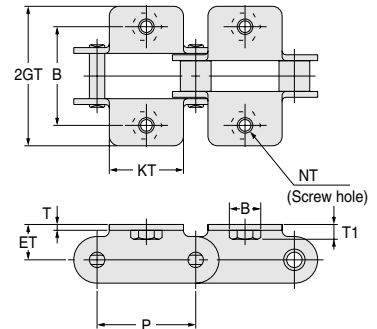

TYPE PK-1

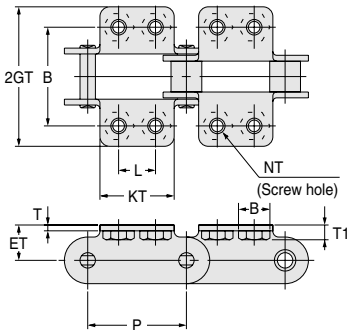

TYPE PK-2

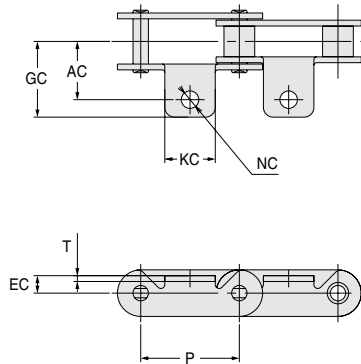

TYPE CA-1

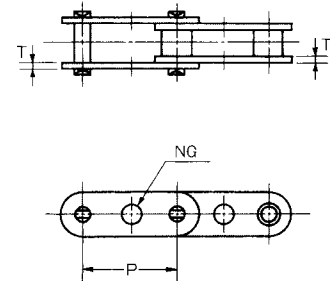

TYPE GK-1

UNIT Upper:inch  
Beneath:mm

OCM Chain No.	Pitch		Pin							Link Plate							Additional Weight Per Attachment		
	P	KT	KC	NT	NC	NG	L	AT	AC	ET	EC	GT	GC	B	T1	T	TA	TK	CA
C2040-C2042	1.000	0.752	0.512		0.177	0.161	0.374	0.500	0.591	0.358	0.177	0.780	0.768	0.319	0.150	0.059	0.007	0.013	0.002
	25.4	19.1	13	M4	4.5	4.1	9.5	12.7	15	9.1	4.5	19.8	19.5	8.1	3.8	1.5	0.003	0.006	0.001
C2050-C2052	1.250	0.937	0.630		0.217	0.205	0.469	0.626	0.709	0.437	0.197	0.965	0.945	0.362	0.201	0.079	0.013	0.026	0.004
	31.75	23.8	16	M5	5.5	5.2	11.9	15.9	18	11.1	5	24.5	24	9.2	5.1	2	0.006	0.012	0.002
C2060H-C2062H	1.500	1.126	0.748		0.205	0.244	0.563	0.843	0.906	0.579	0.244	1.240	1.398	0.453	0.287	0.126	0.037	0.075	0.013
	38.1	28.6	19	M6	5.2	6.2	14.3	21.4	23	14.7	6.2	31.5	35.5	11.5	7.3	3.2	0.017	0.034	0.006
C2080H-C2082H	2.000	1.500	-		-	0.323	0.752	1.094	-	0.752	-	1.602	-	0.591	0.339	0.157	0.082	0.163	-
	50.8	38.1	-	M8	-	8.2	19.1	27.8	-	19.1	-	40.7	-	15	8.6	4	0.037	0.074	-

CA-1 is not available for C2080H and C2082H.

# STRAIGHT LINK PLATE CHAIN

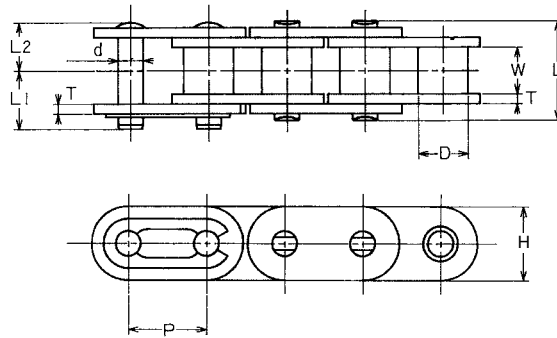

UNIT Upper:inch  
Beneath:mm

OCM Chain No.	Pitch	Roller Diam.	Width between L.P.	Link Plate		Pin Diam.	Pin			Average Tensile Strength	Allowable Load	Approx Weight
	P	D	W	H	T	d	L	L1	L2	Lb/kgf	Lb/kgf	Lb/ft kg/m
40E	0.500	0.312	0.313	0.472	0.059	0.156	0.634	0.382	0.317	4299	904	0.47
	12.7	7.92	7.95	12	1.5	3.96	16.1	9.7	8.05	1950	410	0.7
50E	0.625	0.4	0.376	0.591	0.079	0.2	0.799	0.476	0.4	7165	1455	0.76
	15.875	10.16	9.55	15	2	5.08	20.3	12.1	10.15	3250	660	1.13
60E	0.750	0.469	0.5	0.709	0.094	0.234	1	0.579	0.5	9921	2205	1.09
	19.05	11.91	12.7	18	2.4	5.95	25.4	14.7	12.7	4500	1000	1.62
80E	1.000	0.625	0.626	0.945	0.126	0.313	1.287	0.76	0.644	17637	3638	2.02
	25.4	15.88	15.9	24	3.2	7.94	32.7	19.3	16.35	8000	1650	3
100E	1.250	0.75	0.754	1.181	0.157	0.375	1.571	0.925	0.787	26455	5512	3.16
	31.75	19.05	19.15	30	4	9.53	39.9	23.5	20	12000	2500	4.7
120E	1.500	0.875	1.006	1.425	0.189	0.437	1.972	1.118	0.988	37038	7275	4.66
	38.1	22.23	25.55	36.2	4.8	11.11	50.1	28.4	25.1	16800	3300	6.93

Offset link is not available.  
Duplex, nickel plated and stainless steel are available.

# DEEP LINK PLATE CHAIN

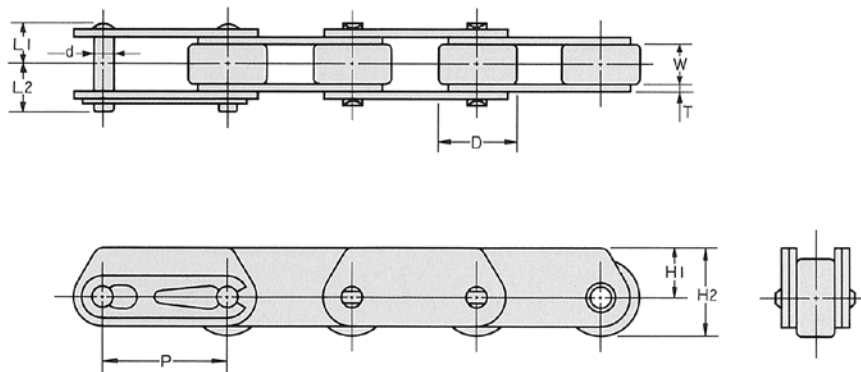

UNIT Upper:inch  
Beneath:mm

OCM Chain No.	Pitch	Roller Diam.	Width between L.P.	Link Plate			Pin Diam.	Pin		Average Tensile Strength	Allowable Load
	P	D	W	H1	H2	T	d	L1	L2	Lb/kgf	Lb/kgf
C2042	1.000	0.625	0.313	0.394	0.705	0.059	0.156	0.315	0.382	3638	595
	25.4	15.88	7.95	10	17.9	1.5	3.96	8	9.7	1650	270
C2052	1.250	0.75	0.376	0.472	0.846	0.079	0.2	0.409	0.476	5952	970
	31.75	19.05	9.55	12	21.5	2	5.08	10.4	12.1	2700	440
C2062H	1.500	0.875	0.5	0.551	0.988	0.126	0.234	0.571	0.661	8598	1323
	38.1	22.23	12.7	14	25.1	3.2	5.95	14.5	16.8	3900	600
C2082H	2.000	1.125	0.626	0.709	1.268	0.157	0.313	0.709	0.839	14771	2205
	50.8	28.58	15.9	18	32.2	4	7.94	18	21.3	6700	1000



# TOP ROLLER CHAIN

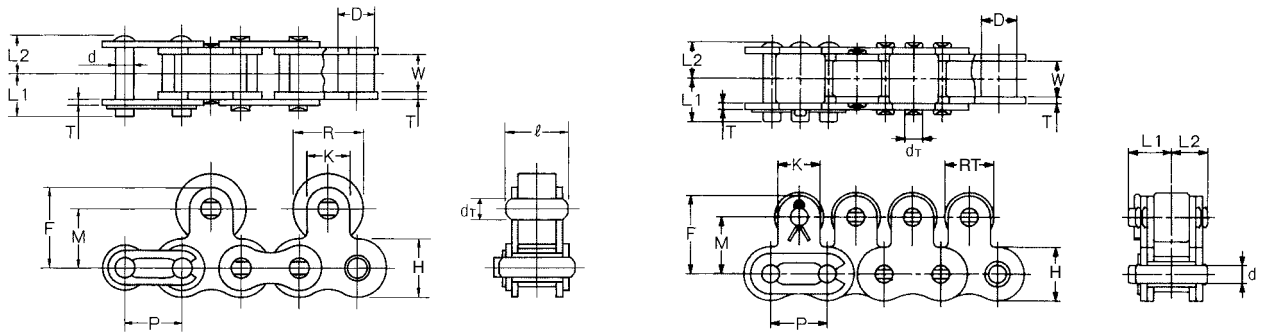

UNIT Upper:inch  
Beneath:mm

OCM Chain No.	Pitch P	Roller Diam. D	Width between L.P. W		Link Plate H T		Pin Diam. d	Pin L1 L2		Pin R RT		Attachment ℓ F K M dr					Average Tensile Strength Lb/kgf	Allowable Load Lb/kgf	Approx Weight	
			Small	Large	Small	Large		Small	Large	Small	Large	Small	Large	Small	Large	Lb/ft			kg/m	
40	0.500	0.312	0.313	0.472	0.059	0.156	0.382	0.319	0.625	0.433	0.504	0.687	0.374	0.5	0.156	3638	617	0.81	1.08	
	12.7	7.92	7.95	12	1.5	3.96	9.7	8.1	15.88	11	12.8	17.45	9.5	12.7	3.96	1650	280	1.2	1.6	
50	0.625	0.4	0.376	0.591	0.079	0.2	0.476	0.409	0.75	0.591	0.626	0.876	0.5	0.626	0.2	5952	1014	1.21	1.34	
	15.875	10.16	9.55	15	2	5.08	12.1	10.4	19.05	15	15.9	22.25	12.7	15.9	5.08	2700	460	1.8	2	
60	0.750	0.469	0.5	0.709	0.094	0.234	0.579	0.5	0.875	0.709	0.799	1.033	0.626	0.72	0.233	8333	1411	1.88	2.15	
	19.05	11.91	12.7	18	2.4	5.95	14.7	12.7	22.23	18	20.3	26.25	15.9	18.3	5.93	3780	640	2.8	3.2	
80	1.000	0.625	0.626	0.945	0.126	0.313	0.74	0.642	1.125	0.945	1.043	1.344	0.752	0.969	0.313	14110	2359	3.09	3.56	
	25.4	15.88	15.9	24	3.2	7.94	18.8	16.3	28.58	24	26.5	34.15	19.1	24.6	7.94	6400	1070	4.6	5.3	
100	1.250	0.75	0.754	1.181	0.157	0.375	0.925	0.787	1.563	0.787	1.24	1.752	1	1.252	0.375	20613	3461	5.17	5.44	
	31.75	19.05	19.15	30	4	9.53	23.5	20	39.69	20	31.5	44.5	25.4	31.8	9.53	9350	1570	7.7	8.1	

Top roller is heat treated. Top roller of poly acetal is available. Supplied on a made to order basis.

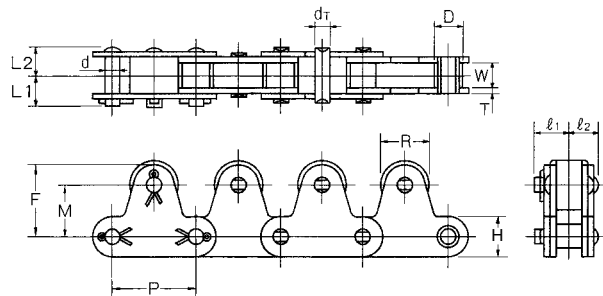

UNIT Upper:inch  
Beneath:mm

OCM Chain No.	Pitch P	Roller Diam. D		Width between L.P. W		Link Plate H T		Pin d L1 L2		Pin R F M		Attachment dr ℓ1 ℓ2			Average Tensile Strength Lb/kgf	Allowable Load Lb/kgf	Approx Weight		
		Small Roller	Large Roller	Small	Large	Small	Large	Small	Large	Small	Large	Small	Large	Lb/ft			kg/m		
C2040-C2042	1.000	0.312	0.625	0.313	0.472	0.059	0.156	0.382	0.319	0.625	0.827	0.591	0.200	0.411	0.329	3638	617	0.89	1.14
	25.4	7.92	15.88	7.95	12	1.5	3.96	9.7	8.1	15.88	21	15	5.08	10.45	8.35	1650	280	1.33	1.69
C2050-C2052	1.250	0.400	0.750	0.376	0.591	0.079	0.200	0.476	0.409	0.750	1.043	0.748	0.233	0.508	0.409	5952	1014	1.37	1.68
	31.75	10.16	19.05	9.55	15	2	5.08	12.1	10.4	19.05	26.5	19	5.93	12.9	10.4	2700	460	2.04	2.5
C2060H-C2062H	1.500	0.469	0.875	0.500	0.677	0.126	0.234	0.650	0.563	0.875	1.244	0.906	0.319	0.713	0.583	8598	1411	2.47	2.93
	38.1	11.91	22.23	12.7	17.2	3.2	5.95	16.5	14.3	22.23	31.6	23	8.09	18.1	14.8	3900	640	3.68	4.36
C2080H-C2082H	2.000	0.625	1.125	0.626	0.945	0.157	0.313	0.839	0.709	1.125	1.594	1.142	0.375	0.866	0.720	14771	2359	3.8	4.54
	50.8	15.88	28.58	15.9	24	4	7.94	21.3	18	28.58	40.5	29	9.53	22	18.3	6700	1070	5.65	6.76
C2100H-C2102H	2.500	0.750	1.563	0.754	1.142	0.189	0.375	0.992	0.850	1.563	1.957	1.394	0.437	0.992	0.862	23149	3461	6.12	7.64
	63.5	19.05	39.69	19.15	29	4.8	9.53	25.2	21.6	39.69	49.7	35.4	11.11	25.2	21.9	10500	1570	9.11	11.37

Weight is for top roller every link. Special sprockets are required for large roller chain. Supplied on a made to order basis.

# ROLLER CHAIN WITH OUTBOARD ROLLER

Standard roller chain with outboard roller. Outboard roller is made of poly acetal.  
 Quiet and smooth operation. Specify spacing of outboard roller when ordering.

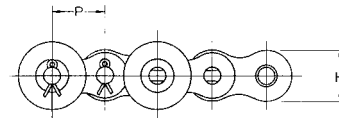
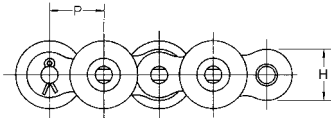
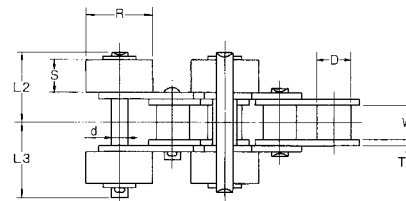
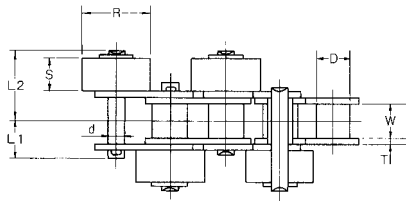

TYPE CH

TYPE PL

UNIT Upper:inch  
Beneath:mm

OCM Chain No.	Pitch	Roller Diam.	Width between L.P.	Link Plate		Pin Diam.	Pin					Average Tensile Strength	Allowable Load	Allowable Load of Outboard Roller	Approx Weight
	P	D	W	H	T	d	L1	L2	L3	R	S	Lb/kgf	Lb/kgf	Lb/kgf	Lb/ft kg/m
40	0.500	0.312	0.313	0.472	0.059	0.156	0.402	0.661	0.744	0.625	0.303	4299	617	11	0.63
	12.7	7.92	7.95	12	1.5	3.96	10.2	16.8	18.9	15.88	7.7	1950	280	5	0.94
50	0.625	0.4	0.376	0.591	0.079	0.2	0.476	0.827	0.898	0.75	0.366	7055	1014	15	0.95
	15.88	10.16	9.55	15	2	5.08	12.1	21	22.8	19.05	9.3	3200	460	7	1.42
60	0.750	0.469	0.5	0.709	0.094	0.234	0.598	1.067	1.157	0.875	0.488	9811	1411	22	1.42
	19.05	11.91	12.7	18	2.4	5.95	15.2	27.1	29.4	22.23	12.4	4450	640	10	2.11
80	1.000	0.625	0.626	0.949	0.126	0.313	0.776	1.331	1.465	1.125	0.614	16535	2359	40	2.4
	25.4	15.88	15.9	24.1	3.2	7.94	19.7	33.8	37.2	28.58	15.6	7500	1070	18	3.57
100	1.250	0.75	0.754	1.185	0.157	0.375	0.925	1.63	1.768	1.563	0.748	24251	3461	66	3.74
	31.75	19.05	19.15	30.1	4	9.53	23.5	41.4	44.9	39.69	19	11000	1570	30	5.56

Weight is for outboard roller every link for CH type and every 2nd for PL type.  
 White and black are available.

Extend pitch roller chain with outboard roller of poly acetal.

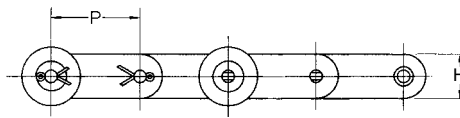
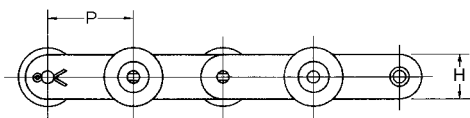
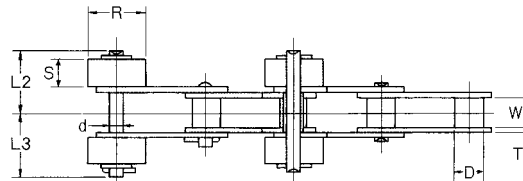
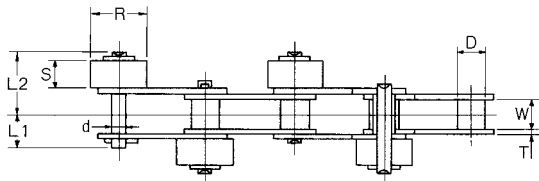

TYPE CH

TYPE PL

UNIT Upper:inch  
Beneath:mm

OCM Chain No.	Pitch	Roller Diam.	Width between L.P.	Link Plate		Pin Diam.	Pin					Average Tensile Strength	Allowable Load	Allowable Load of Outboard Roller	Approx Weight
	P	D	W	H	T	d	L1	L2	L3	R	S	Lb/kgf	Lb/kgf	Lb/kgf	Lb/ft kg/m
C2040	1.000	0.312	0.313	0.472	0.059	0.156	0.402	0.661	0.744	0.625	0.303	4299	617	11	0.44
	25.4	7.92	7.95	12	1.5	3.96	10.2	16.8	18.9	15.88	7.7	1950	280	5	0.66
C2050	1.250	0.4	0.376	0.591	0.079	0.2	0.476	0.827	0.898	0.75	0.366	7055	1014	15	0.69
	31.75	10.16	9.55	15	2	5.08	12.1	21	22.8	19.05	9.3	3200	460	7	1.03
C2060H	1.500	0.469	0.5	0.677	0.126	0.234	0.669	1.134	1.228	0.875	0.488	9811	1411	22	1.21
	38.1	11.91	12.7	17.2	3.2	5.95	17	28.8	31.2	22.23	12.4	4450	640	10	1.8
C2080H	2.000	0.625	0.626	0.945	0.157	0.313	0.839	1.398	1.531	1.125	0.614	16535	2359	40	2.1
	50.8	15.88	15.9	24	4	7.94	21.3	35.5	38.9	28.58	15.6	7500	1070	18	3.12
C2100H	2.500	0.75	0.754	1.142	0.189	0.375	0.992	1.697	1.835	1.563	0.748	24251	3461	66	3.21
	63.5	19.05	19.15	29	4.8	9.53	25.2	43.1	46.6	39.69	19	11000	1570	30	4.77

Weight for outboard roller every link for CH type and every 2nd for PL type.

# WIDE CHAIN WITH CROSSRODS

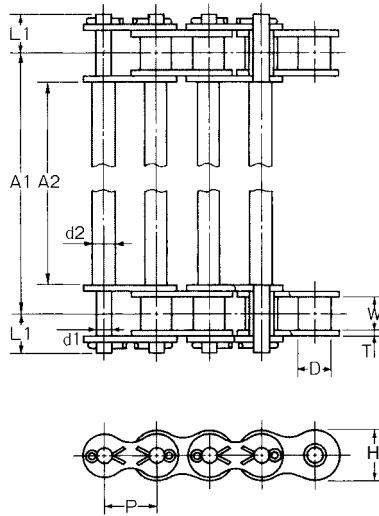

UNIT Upper:inch  
Beneath:mm

OCM Chain No.	Pitch	Roller Diam.	Width between L.P.	Link Plate		Pin		d2	Bar A1,A2
	P	D	W	H	T	d1	L1		
40	0.500	0.313	0.313	0.472	0.059	0.156	0.402	0.244	Specify either A1 or A2
	12.7	7.94	7.95	12	1.5	3.96	10.2	6.2	
50	0.625	0.4	0.376	0.591	0.079	0.2	0.476	0.276	
	15.875	10.16	9.55	15	2	5.08	12.1	7	
60	0.750	0.469	0.5	0.709	0.094	0.234	0.598	0.319	
	19.05	11.91	12.7	18	2.4	5.95	15.2	8.09	
80	1.000	0.625	0.626	0.945	0.126	0.313	0.776	0.381	
	25.4	15.88	15.9	24	3.2	7.94	19.7	9.68	

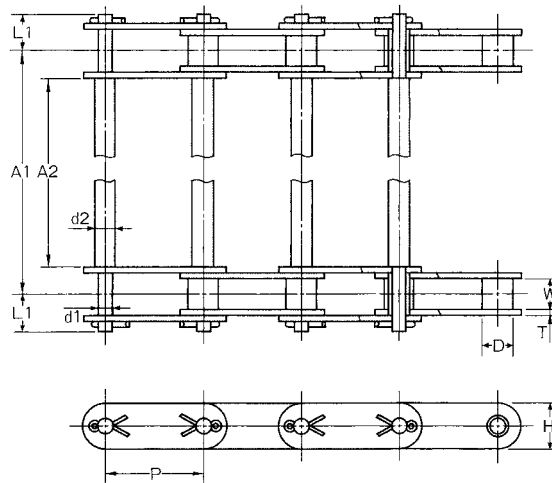

UNIT Upper:inch  
Beneath:mm

OCM Chain No.	Pitch	Roller Diam. D		Width between L.P.	Link Plate		Pin		Bar	
	P	Small Roller	Large Roller	W	H	T	d1	L1	d2	A1,A2
C2040-C2042	1.000	0.313	0.625	0.313	0.472	0.059	0.156	0.402	0.244	Specify either A1 or A2
	25.4	7.94	15.88	7.95	12	1.5	3.96	10.2	6.2	
C2050-C2052	1.250	0.4	0.75	0.376	0.591	0.079	0.2	0.476	0.276	
	31.75	10.16	19.05	9.55	15	2	5.08	12.1	7	
C2060H-2062H	1.500	0.469	0.875	0.5	0.677	0.126	0.234	0.661	0.319	
	38.1	11.91	22.23	12.7	17.2	3.2	5.95	16.8	8.09	
C2080H-C2082H	2.000	0.625	1.125	0.626	0.945	0.157	0.313	0.839	0.381	
	50.8	15.88	28.58	15.9	24	4	7.94	21.3	9.68	

# HOLLOW PIN CHAIN

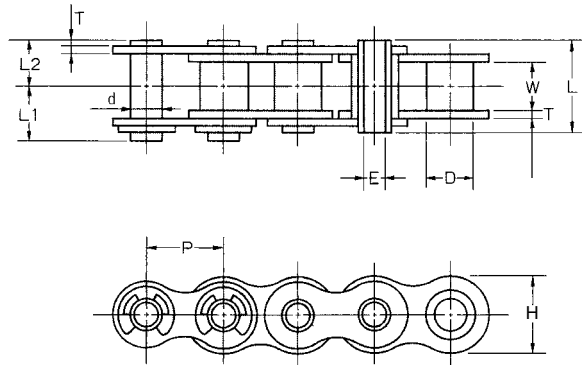

UNIT Upper:inch  
Beneath:mm

OCM Chain No.	Pitch P	Roller Diam. D	Width between L.P. W	Pin Diam. d	Trans Pitch E (MIN)	Pin			Link Plate		Average Tensile Strength Lb/kgf	Allowable Load Lb/kgf	Approx Weight Lb/ft kg/m
						L	L1	L2	H	T			
40HP	0.500	0.312	0.313	0.222	0.157	0.63	0.362	0.315	0.472	0.059	2425	397	0.34
	12.7	7.92	7.95	5.65	4	16	9.2	8	12	1.5	1100	180	0.51
50HP	0.625	0.4	0.376	0.284	0.202	0.799	0.451	0.4	0.591	0.079	4409	705	0.56
	15.875	10.16	9.55	7.21	5.12	20.3	11.45	10.15	15	2	2000	320	0.84
60HP	0.750	0.469	0.5	0.327	0.236	1	0.559	0.5	0.709	0.094	6063	948	0.83
	19.05	11.91	12.7	8.3	6	25.4	14.2	12.7	18	2.4	2750	430	1.23
80HP	1.000	0.625	0.626	0.433	0.315	1.287	0.703	0.644	0.949	0.126	10803	1720	1.48
	25.4	15.88	15.9	11	8	32.7	17.85	16.35	24.1	3.2	4900	780	2.2

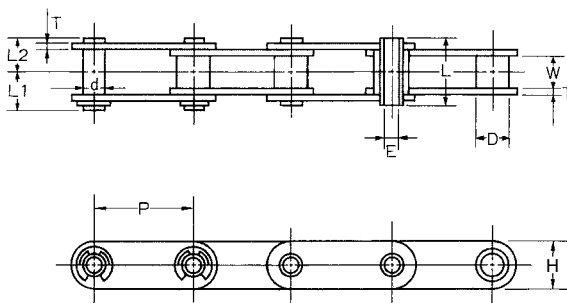

TYPE BUSH

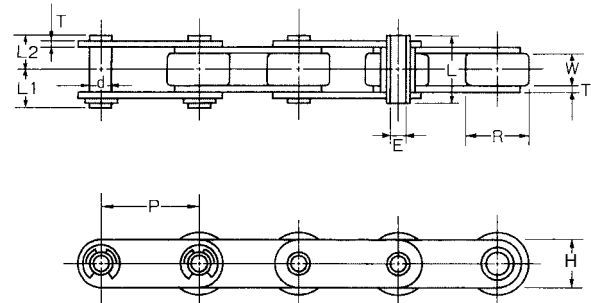

TYPE ROLLER

UNIT Upper:inch  
Beneath:mm

OCM Chain No.	Pitch P	Roller Diam. D	R	Width between L.P. W	Pin Diam. d	Trans Pitch E (MIN)	Pin			Link Plate		Average Tensile Strength Lb/kgf	Allowable Load Lb/kgf	Approx Weight	
							L	L1	L2	H	T			Lb/ft	kg/m
C2040HP-C2042HP	1.000	0.312	0.625	0.313	0.222	0.157	0.63	0.362	0.315	0.472	0.059	2425	397	0.3	0.53
	25.4	7.92	15.88	7.95	5.65	4	16	9.2	8	12	1.5	1100	180	0.45	0.79
C2050HP-C2052HP	1.250	0.4	0.75	0.376	0.284	0.202	0.799	0.451	0.4	0.591	0.079	4409	705	0.5	0.8
	31.75	10.16	19.05	9.55	7.21	5.12	20.3	11.45	10.15	15	2	2000	320	0.74	1.19
C2060HP-C2062HP	1.500	0.469	0.875	0.5	0.327	0.236	1	0.559	0.5	0.677	0.094	6063	948	0.69	1.15
	38.1	11.91	22.23	12.7	8.3	6	25.4	14.2	12.7	17.2	2.4	2750	430	1.02	1.71
C2080HP-C2082HP	2.000	0.625	1.125	0.626	0.433	0.315	1.287	0.703	0.644	0.945	0.126	10803	1720	1.28	1.98
	50.8	15.88	28.58	15.9	11	8	32.7	17.85	16.35	24	3.2	4900	780	1.91	2.94

# INDENTED ATTACHMENTS

Indented attachment chain.

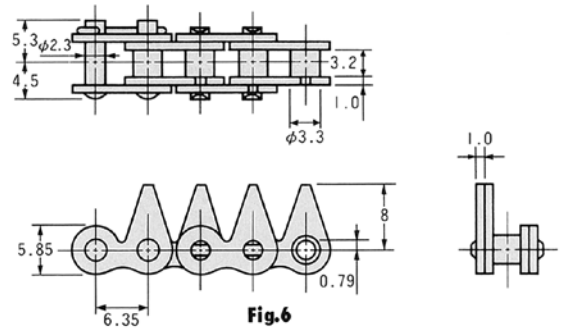
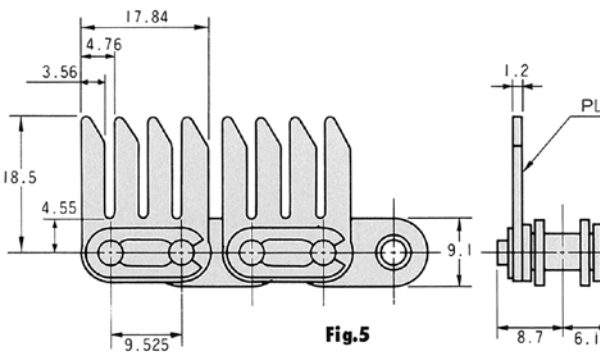
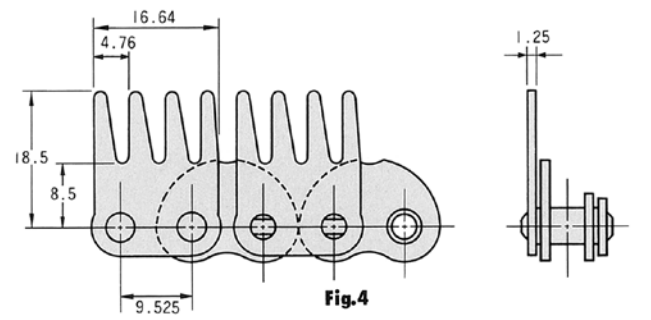
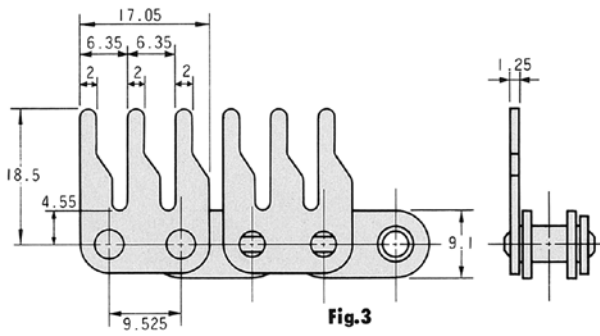
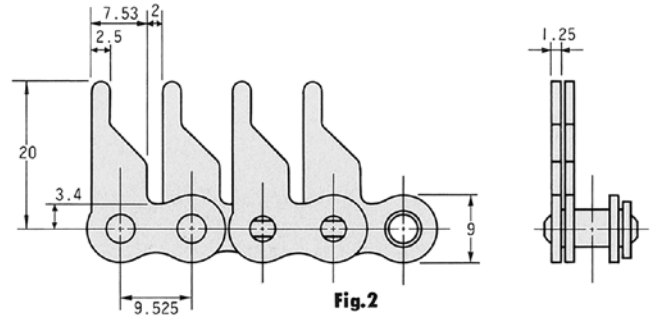
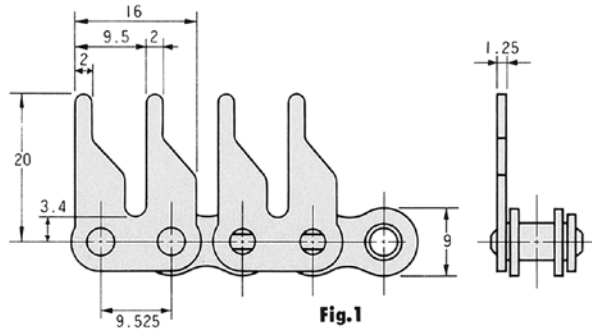
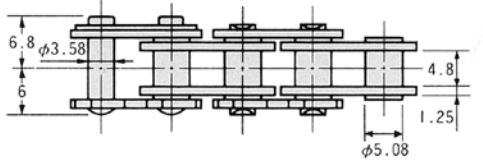

# BAI-SPEED CHAIN

Roller Specifications.

Combination Code	VS-A	VS-B	VS-C	VS-D
Features	Standard type Large allowable tension	Standard type High friction type Quick start-up and less noise	Electro conductive Large allowable tension	Electro conductive High friction type Quick start-up

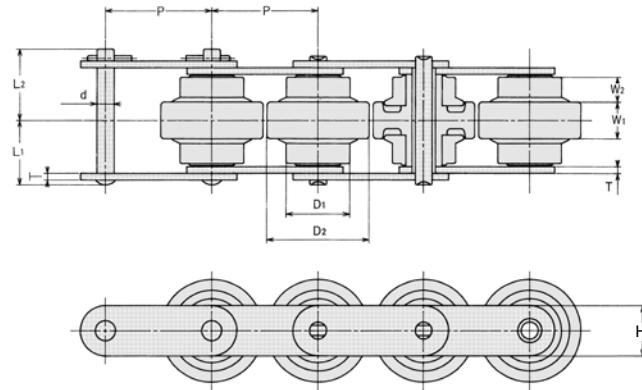

UNIT:mm

OCM Chain No.	Pitch P	Roller Diam.		Roller Width		Plate		Pin			Material	Allowable Tension		Approx Weight kg/m
		D1	D2	W1	W2	H	T	d	L1	L2		Roller A.C kgf	Roller B.D kgf	
C2040-VS	25.4	15.88	25.0	9.3	6.1	12.0	1.5	3.96	15.25	17.65	Carbon	90	45	1.0
												45	45	
C2050-VS	31.75	19.05	30.6	11.0	7.6	15.0	2.0	5.08	19.2	21.4	Carbon	140	70	1.3
												70	70	
C2060-VS	38.1	22.23	36.6	15.0	8.2	17.2	3.2	5.95	24.3	26.5	Carbon	210	105	2.3
												105	105	

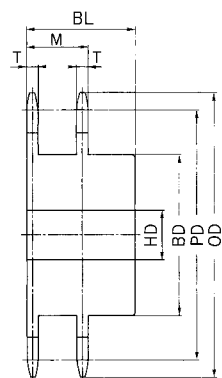

UNIT:mm

OCM Chain No.	Type	Number of teeth	PD	OD	Link Plate T	HD	BD	BL	M	Material	Weight kg
C2040-VS	B	10	82.2	93	4	17	52	40	20.4	S43C	0.8
C2050-VS	B	10	102.75	117	5	20	66	45	25.5	S43C	1.5
C2060-VS	B	10	123.3	137	6	20	81	50	30.5	S43C	2.5

# APPLICATIONS FOR CUSTOM ATTACHMENT CHAIN

The chains shown are examples specially designed to meet users' requirements. A wide variety of custom attachment chain is manufactured daily. Please contact OCM for any question and quotation.



Conveying equipment



Conveying resistors, welding rods, etc.



Conveying resistors, welding rods, etc.



Conveying resistors, welding rods, etc.



For shutter opening and closing



Binder for agricultural machine

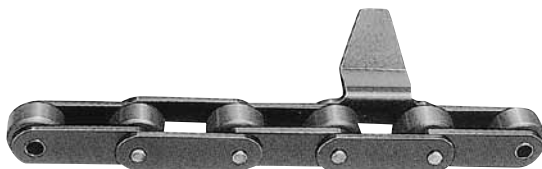

Conveying equipment



Skylight opening and closing



For agricultural machine



Conveying pallets



Conveying pallets

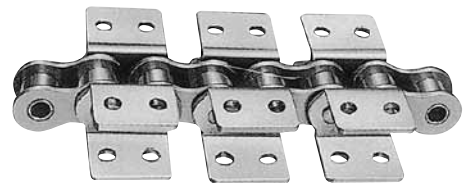

Conveying foods



Conveying foods

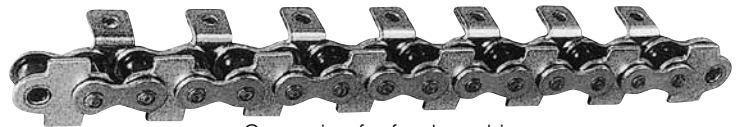

Conveying for food machinery



Conveying noodle



Clipping chain for clipping film



Clipping chain for clipping film



For shutter closing and opening

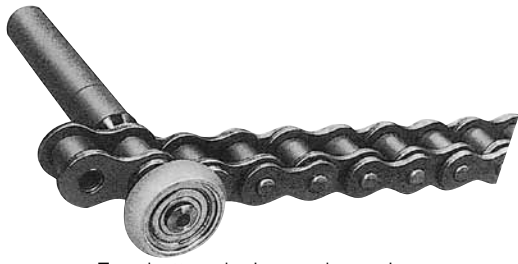

For shutter closing and opening



For conveying pallets

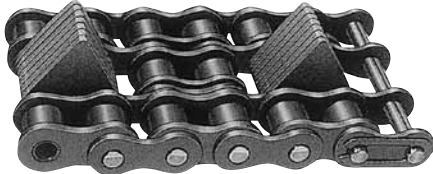

For conveying logs



For conveying medical instruments



For conveying foamed styrol

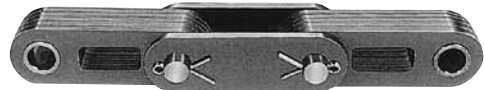

For construction machinery

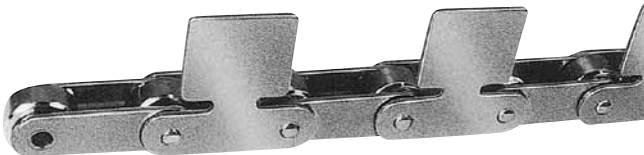

Conveying machinery parts

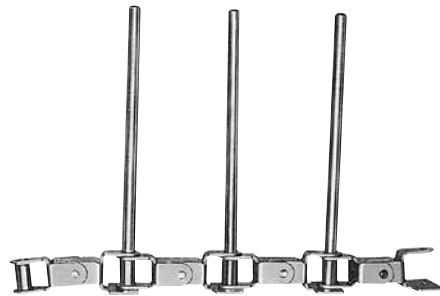

For curved conveyance

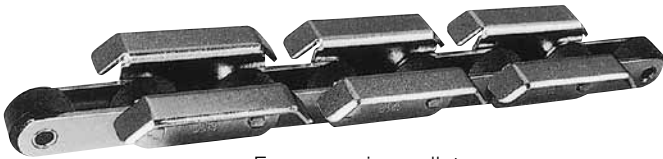

For conveying pallets



Paper conveyance

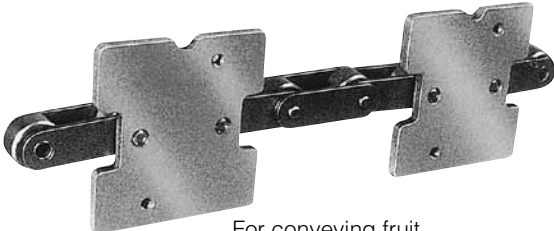

For conveying fruit

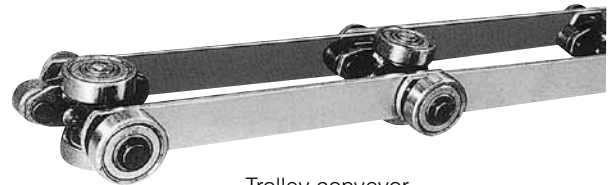

Trolley conveyor

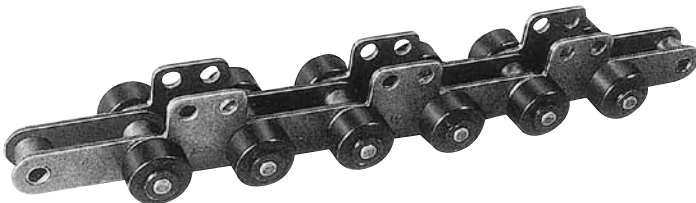

For pallet conveying line

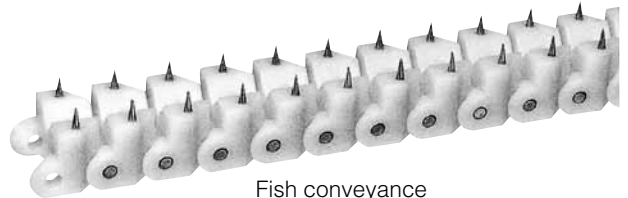

Fish conveyance

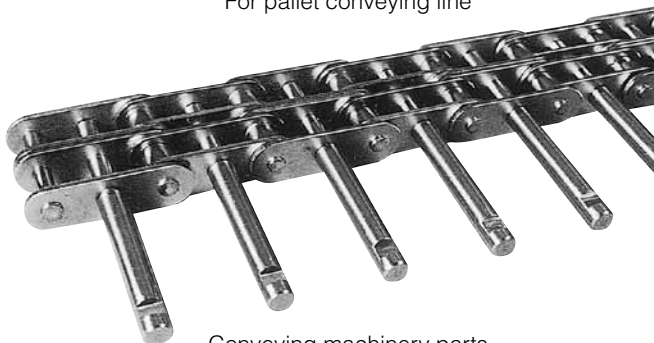

Conveying machinery parts

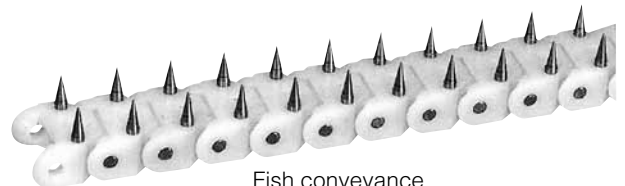

Fish conveyance



# CUTTING AND CONNECTING OF CHAIN

To cut and connect chain, chain anvil and punches with hammer are used.

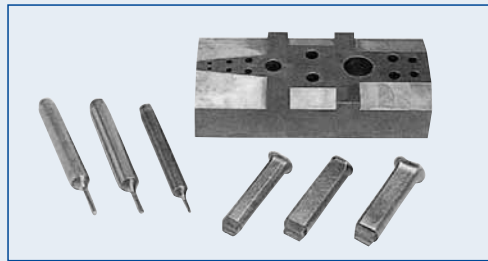

Punches and chain anvil

## Cutting

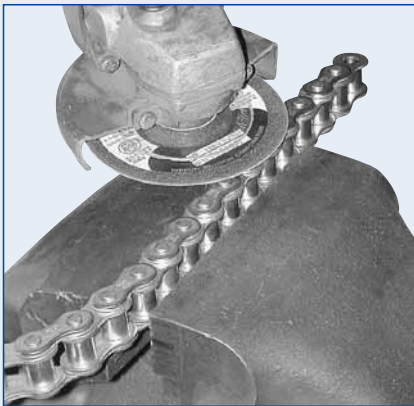

No.1  
As to rivet type chain, grind the end of two pins.

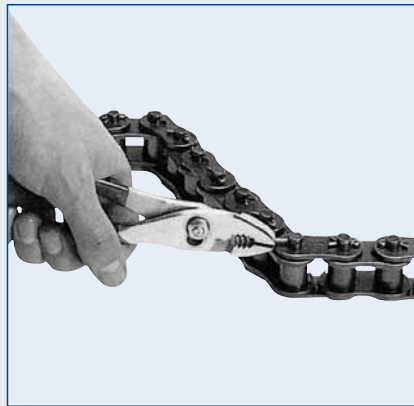

No.2  
As to cotter chain, pull cotter keys out.

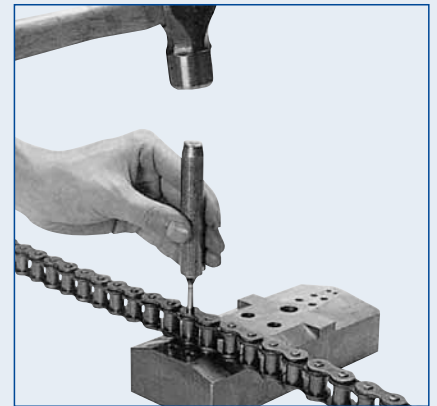

No.3  
Place the chain on suitable holes of the chain anvil. Put a punch on two pins and hammer them alternately and equally to push them out.

## Connecting



Wind the chain on sprocket and put two pins of connecting link into bushes of the chain.



Insert the plate of connecting link and put spring clip or cotter keys to hold it.

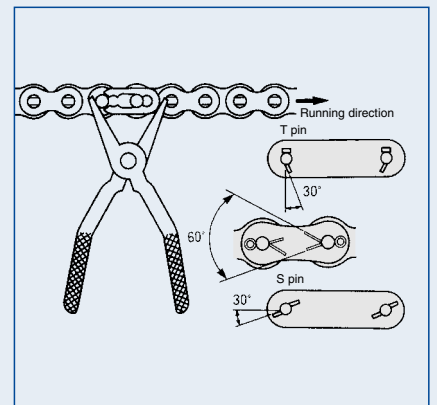

Spring clip should be inserted with its opening opposite the chain running direction.

T pin should be bent 30 degrees, Cotter keys 60 degrees and S pins 30 degrees as shown above.

# OCM CONVEYOR CHAIN

## CONVEYOR CHAIN

### CONSTRUCTION OF CONVEYOR CHAIN

There are many types of chains for conveyor applications, but steel conveyor chains are popular and widely used. OCM FM and FE type conveyor chains are superior to other types in strength,

wear-resistance and the characteristics that changes in material and attachment are readily made according to an application.

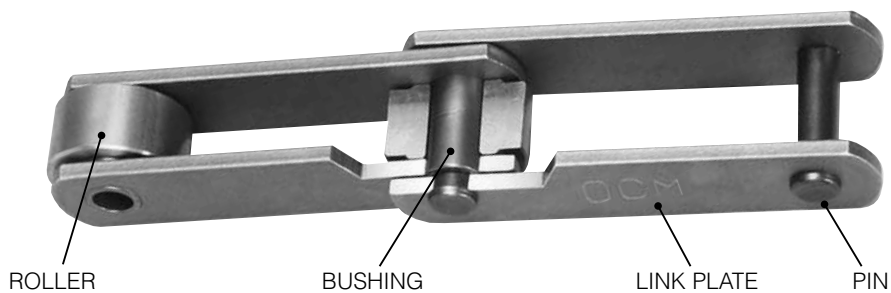

### CONVEYOR TYPE BY ROLLER

#### 1. R Roller

The outside diameter of roller is larger than the height of link plate. This type of conveyor is used mainly for slat, pallet, flight conveyors, etc.



#### 2. F Roller

Flanged roller. This type is widely used on slat, inclined bucket and pan conveyors.



#### 3. S Roller

The outside diameter of roller is smaller than the height of link plate. This is used for bucket elevator and flow conveyors.



### STANDARD ATTACHMENT

Attachments are attached according to requirements. The following three basic types are standard.

#### 1. Type A

A-1 indicates one hole. A-2 two holes.



#### 2. Type K

K-1 indicates one hole. K-2 two holes.



#### 3. Type G

G-2 indicates two holes. G-4 four holes.



# STANDARD CONVEYOR CHAIN

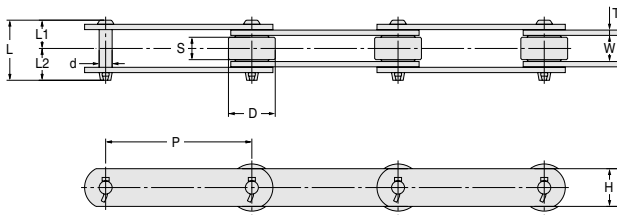

R ROLLER

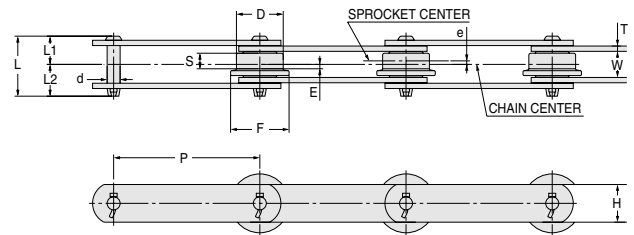

F ROLLER

OCM Chain No.	Type of roller	Average Breaking Strength						Pitch P	Roller Dimensions				
		Standard kN	FE FM kgf	Heavy Duty kN	FMH.FEH kgf	Stainless steel kN	kgf		R		F		
								D	S	D	F	S	
FM.FMH 3075 FM.FMH 3100 FM.FMH 3125 FM.FMH 3150	R.F.S	29.41	3000	60.78	6200	29.41	3000	75 100 125 150	30 (31.8)	15.5	30 (31.8)	38 (42)	12
FM.FMH 5075 FM.FMH 5100 FM.FMH 5125 FM.FMH 5150	R.F.S	68.64	7000	138.24	14100	68.64	7000	75 100 125 150	40	19	40	50	14
FM.FMH 7100 FM.FMH 7125 FM.FMH 7150 FM.FMH 7175 FM.FMH 7200	R.F.S	84.31	8600	171.57	17500	73.55	7500	100 125 150 175 200	45	21.5	45	60	16
FM.FMH 10100 FM.FMH 10125 FM.FMH 10150 FM.FMH 10200	R.F.S.M	112.75	11500	225.49	23000	102.96	10500	100 125 150 200	50	26.5	50	65	20
FM.FMH 12200 FM.FMH 12250	R.F.S.M	186.32	19000	277.45	28300	132.38	13500	200 250	65	32	65	85	24
FM.FMH 17200 FM.FMH 17250 FM.FMH 17300	R.F.S.M	245.1	25000	392.16	40000	186.32	19000	200 250 300	80	45.8	80	105	34
FM.FMH 20200 FM.FMH 20250	R.F.S	205.88	21000	441.18	45000	-	-	200 250	75	40.5	75	100	30
FM.FMH 26250 FM.FMH 26300 FM.FMH 26450	R.F.S.M	279.41	28500	529.41	54000	-	-	250 300 450	100	50	100	130	38
FM.FMH 36250 FM.FMH 36300 FM.FMH 36450 FM.FMH 36600	R.F.S.M	475.49	48500	686.42	70000	-	-	250 300 450 600	125	56	125	160	42
FM.FMH 52450 FM.FMH 52600	R.F.S	539.22	55000	1078.43	110000	-	-	450 600	140	65	140	180	49
FE.FEH 3400	R.F.S	53.92	5500	98.04	10000	44.12	4500	101.6	38.1	18.7	38.1	50	13
FE.FEH 5400 FE.FEH 5600	R.F.S.M	83.33	8500	132.35	13500	68.64	7000	101.6 152.4	44.45 50.8	23.5 26.5	44.45 50.8	60 65	21.5 20
FE.FEH 9400	R.F.S.M	137.25	14000	274.57	28000	122.58	12500	101.6	44.45	27.5	44.45	60	19.5
FE.FEH 12600	R.F.S.M	186.32	19000	274.57	28000	132.38	13500	152.4	57.2	31.5	57.2	75	25
FE.FEH 17600	R.F.S.M	205.88	21000	392.16	40000	186.32	19000	152.4	69.9	31.5	69.9	90	23.5
FE.FEH 5261	S	83.33	8500	132.35	13500	68.64	7000	66.27	-	-	-	-	-
FE.FEH 7400	S	98.04	10000	166.71	17000	73.54	7500	101.6	-	-	-	-	-
FE.FEH 9307	S	117.65	12000	225.49	23000	102.96	10500	78.11	-	-	-	-	-

Note: Figures parenthesized for FM3000 are for FMS3000.  
 \* parenthesized indicate Heavy duty type and stainless steel.

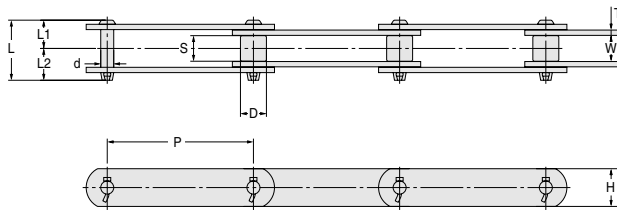

S (M) ROLLER

UNIT:mm

e	E	S D	M D	Width between L.P. W	Link Plate		Pin				Weight (kg/m)			
					H	T	d	L	L1	L2	R	F	S	M
2 (1.8)	4 (4.3)	19.05 (15.9)	-	18 (16.1)	22	3.2	7.94	38 (36.4)	18 (17.1)	20 (19.3)	2.5	2.7	2	-
											2.2	2.3	1.8	-
											2	2.1	1.6	-
											1.9	2	1.4	-
2.5	4.5	22.2	-	22.2	32	4.5	11.11	51	24	27	5.6	5.8	5.4	-
											5	5.2	4.8	-
											4.5	4.7	4.3	-
											4.1	4.3	3.9	-
3	5	27	-	25	32	6	12.7	61.5	29	32.5	6.8	7.2	6	-
											6.1	6.5	5.5	-
											5.5	5.8	5	-
											5	5.4	4.5	-
											4.5	4.9	4	-
3.5	6.5	30	31.8	30	38	6.3 *(6.0)	14.29	68	32	36	10	10.2	9.4	9.8
											8.7	8.9	8.1	8.5
											7.5	7.7	6.9	7.2
											6.5	6.7	5.9	6.2
4	8	34.93	38.1	36.5	45	7.9 *(8.0)	15.88	85.5	39.5	46	11.6	12.2	8.4	8.7
											10.4	10.9	7.8	8
5	12	40.08	44.5	50.8	50.8	9.5 *(9.0)	19.05	110.5	51	59.5	19.7	20.7	12	13
											17.2	18.2	11.1	12.2
5	10	40	-	45	50.8	9.5 *(9.0)	20.64	103	47.5	55.5	16.8	17.8	-	-
											14.8	15.7	-	-
6	13	44.45	50.8	56.6	63.5	9.5 *(9.0)	22.23	116	54	62	26.2	27.8	14.7	16
											23.4	24.7	13.8	15
											18.7	19.6	12.4	14.5
7	14	50.8	57.2	66	76.2	12.7 *(12.0)	25.4	141	65.5	75.5	45.7	47.6	24	25
											40.4	42	22.9	24
											31.8	33.3	20.2	21
											27.8	29	19	20
8	16.5	57.1	-	76	90	16	32	169	79	90	45.8	48	26.2	-
											39.8	41.8	24.2	-
2.5	4	20.1	-	22.2	25.4	4.8 *(4.5)	9.53	51	24	27	4.3	4.7	3	-
2.3	8.5	22.2	25.4	27	28.6	6.3	11.11	63	30	33	6.7	6.9	4.6	4.9
3	7	25.8	-	30	38	6.3 *(6.0)	11.11	66	31.5	34.5	7.8	8.1	5	-
3.8	6	31.75	34.9	31	38	7.9 *(8.0)	15.88	78.5	37	41.5	10.4	10.7	8.7	9.1
3.5	9	34.93	38.1	36.5	45	7.9 *(8.0)	15.88	86	40	46	12.1	12.4	9.3	9.6
3.8	8	40.08	44.4	36.5	50.8	9.5 *(9.0)	19.05	94	43.5	50.5	17.1	17.6	12.6	13
-	-	22.2	-	27	28.6	6.3 *(6.0)	11.11	63	30	33	-	-	5.6	-
-	-	25	-	28.6	38	6.3 *(6.0)	12.7	66	31	35	-	-	6.5	-
-	-	31.75	-	36.5	38	7.9 *(8.0)	14.29	81.5	39	42.5	-	-	10.3	-

# ATTACHMENT CONVEYOR CHAIN

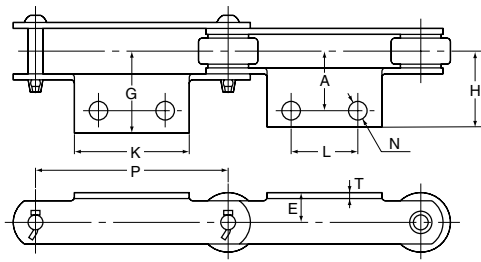

TYPE A-2

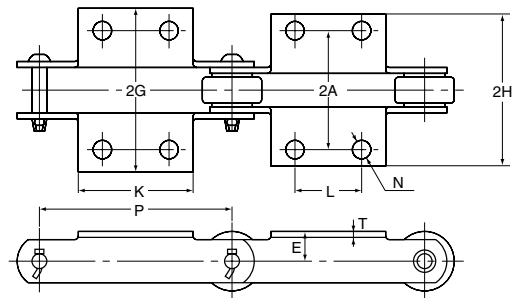

TYPE K-2

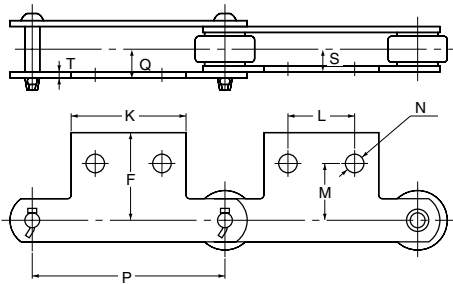

TYPE SA-2

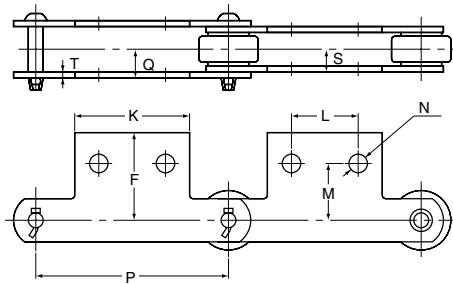

TYPE SK-2

UNIT:mm

OCM Chain No.	Pitch P	Link Plate T	A-2 and K-2 Attachment							SA-2 and SK-2				Weight Attachment kg	
			K	N	L	A	E	G	H	M	F	S	Q	A-2	K-2
			P	T	K	N	L	A	E	G	H	M	F	S	Q
FM 3075-R.F.S	75		58(55)		35(30)									0.05	0.10
FM 3100-R.F.S	100		65		40									0.06	0.12
FM 3125-R.F.S	125	3.2	75	10	50	30	(20)	46	42.4	30	42	12.2	15.8	0.06	0.12
FM 3150-R.F.S	150		85		60									0.07	0.14
FM 5075-R.F.S	75		58		35									0.07	0.14
FM 5100-R.F.S.	100		65		40									0.08	0.16
FM 5125-R.F.S	125	4.5	75	10	50	35	22	47	47	40	54	15.6	20.5	0.09	0.18
FM 5150-R.F.S	150		85		60									0.10	0.20
FM 7100-R.F.S	100		70		40									0.20	0.40
FM 7125-R.F.S	125		80		50									0.22	0.44
FM 7150-R.F.S	150	6.0	90	12	60	40	25	63	56.6	45	58	18.5	24.9	0.25	0.50
FM 7175-R.F.S	175		100		70									0.28	0.56
FM 10100-R.F.S.M	100		70		40									0.18	0.36
FM 10125-R.F.S.M	125		80		50									0.23	0.46
FM 10150-R.F.S.M	150	6.3	90	12	60	50	28	74	67.2	50	69	21.3	28.1	0.28	0.56
FM 10200-R.F.S.M	200		120		80									0.37	0.74
FM 12200-R.F.S.M	200		120		80									0.42	0.84
FM 12250-R.F.S.M	250	7.9	170	15	125	60	38	85	76.5	60	82.5	26.2	34.7	0.58	1.16
FM 17200-R.F.S.M	200		120		80									0.80	1.60
FM 17250-R.F.S.M	250	9.5	170	15	125	75	45	108	97.7	70	100.6	34.9	45.2	1.11	2.22
FM 26250-R.F.S.M	250	9.5	170	15	125	80	55	111.5	101.2	80	111.3	37.8	48.1	1.17	2.34
FE 3400-R.F.S	101.6	4.8	70	11	40	40	22	59	53.9	40	55.3	15.9	21	0.15	0.30
FE 5400-R.F.S.M	101.6	6.3	70	11	40	50	28	74	67.3		70.7	19.8	26.5	0.20	0.40
FE 5600-R.F.S.M	152.4	6.3	90	11	60	50	32	72	65.2	50	71	21.3	28.1	0.25	0.50
FE 9400-R.F.S.M	101.6	7.9	80	15	40	55	35	84	75.6	60	81	23.4	31.8	0.30	0.60
FE 12600-R.F.S.M	152.4	7.9	100	15	60	60	38	85	76.5	60	82.5	26.2	34.7	0.40	0.80
FE 17600-R.F.S.M	152.4	9.5	100	15	60	65	45	94.5	84.3	70	94.6	27.8	38	0.55	1.10

Note: 1) Cotter types are standard for Chain Nos. 5000 and below but rivet types are available. Cotter types are standard for Chain Nos. 7000 and above.  
 2) Cotter keys used for cotter construction of FM3000 and FMS3000. T pins are used for other chain sizes.  
 3) Dimensions parenthesized of FM3000 is for FMS3000.

# ATTACHMENT CONVEYOR CHAIN

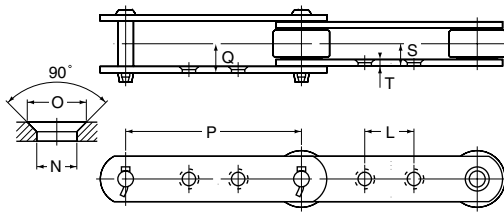

TYPE G-2

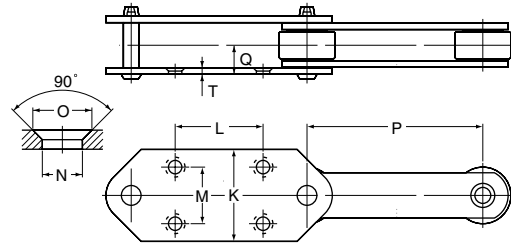

TYPE G-4

TYPE G-2

UNIT:mm

OCM Chain No.	Pitch P	Link Plate T	Dimensions of Type G-2					Limited height of installing bolts		Diameter of bolts used
			N	O	L	Q	S	Outside link	Inside link	
FM 3075-R.S	75				30					
FM 3100-R.F.S	100	3.2	8	13	40	15.8	12.2	27	20	M6
FM 5100-R.S.	100				40					
FM 5150-R.F.S.	150	4.5	9.5	17	60	20.5	15.6	35	25	M8
FM 10100-S	100				30					
FM 10150-R.F.S.M	150	6.3	11	22	60	28.1	21.3	49	35	M10
FM 12200-R.F.S.M	200				80					
FM 12250-R.F.S.M	250	7.9	15	27	125	34.7	26.2	63	45	M12
FM 17200-R.F.S.M	200				80					
FM 17250-R.F.S.M	250	9.5	15	27	110	45.2	34.9	80	60	M12
FM 17300-R.F.S.M	300				150					
FM 26300-R.F.S.M	300				140					
FM 26450-R.F.S.M	450	9.5	15	27	220	48.1	37.8	86	64	M12
FM 36450-R.F.S.M	450				220					
FM 36600-R.F.S.M	600	12.7	19	32	300	59.2	45.7	105	78	M16
FM 52450-R.F.S	450				220					
FM 52600-R.F.S	600	16	22	38	300	71	54	124	89	M18
FE 5600-R.F.S	152.4	6.3	11	22	60	28.1	21.3	48	34	M10
FE 12600-R.F.S	152.4	7.9	15	27	50	34.7	26.2	62	44	M12

Note: 1) Cotter type is standard for Chain Nos. 5000 and below, but rivet type is available.  
 2) Cotter type is standard for Chain Nos. 7000 and above.  
 3) Cotter key is for FM3000 and FMS3000 and T pins for other chain sizes.

TYPE G-4

UNIT:mm

OCM Chain No.	Pitch P	Link Plate T	Dimensions of Type G-4						Weight per pc. kg	Approx weight of att every 2nd (kg/m)			
			N	O	L	M	K	Q		R type	F type	S type	B type
FM 5150-R.F.S	150	4.5	9.5	17	75	70	100	20.5	0.43	5.5	5.7	5.3	4.4
FM 10150-R.F.S.M	150	6.3	11	22	75	70	110	28.1	0.61	9.5	9.7	8.9	7.7
FM 12200-R.F.S.M	200				100	80	130		0.97	14	14.6	10.8	-
FM 12250-R.F.S.M	250	7.9	15	27	140	100	150	34.7	1.45	13.3	13.8	10.7	-
FM 17200-R.F.S.M	200				100	80	130		1.12	22.5	23.5	14.8	-
FM 17250-R.F.S.M	250	9.5	15	27	140	100	150	45.2	1.69	20.6	21.6	14.5	-
FM 17300-R.F.S.M	300				180	120	170		2.39	19.8	20.6	14.5	-
FM 26300-R.F.S.M	300				180	120	170		2.24	27.1	28.4	17.5	-
FM 26450-R.F.S.M	450	9.5	15	27	250	140	190	48.1	3.98	23.1	24	16.8	-
FM 36250-S	250				140	100	150		1.98	-	-	27.9	-
FM 36300-S	300	12.7	15	27	180	100	150	59.2	2.38	-	-	26.8	-
FE 5600-R.F.S.M	152.4	6.3	11	22	75	70	110	28.1	0.50	9.4	9.7	7.6	-
FE 12600-R.F.S.M	152.4	7.9	15	27	75	70	120	34.7	0.53	13.8	14.1	11	-

Note: 1) Cotter type is standard for Chain Nos. 5000 and below, but rivet type is available.  
 2) Cotter type is standard for Chain Nos. 7000 and above.  
 3) T pin is standard for cotter type.

# FLOW CONVEYOR CHAIN

The chains are ideal for preventing environmental pollution because they convey powdered material and grain in sealed case.

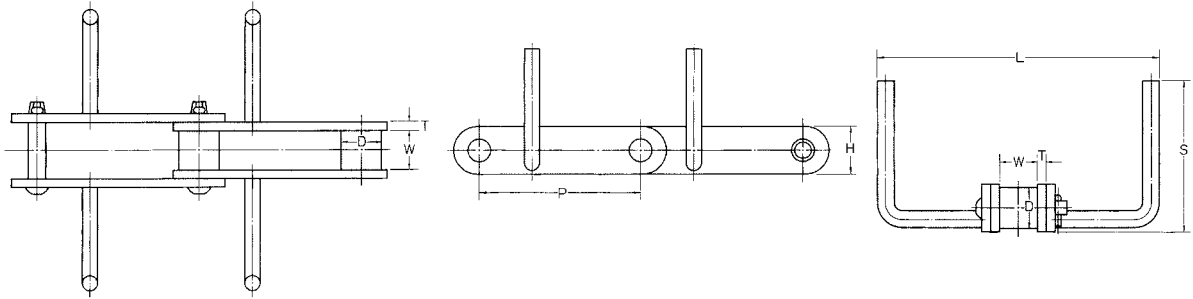

TYPE B

TYPE B

UNIT:mm

OCM Chain No.	Pitch P	Roller Diam. D	Width between L.P. W	Link Plate		Attachment		Average Breaking load		Approx weight
						Width	Height			
						L	S	kN	kgf	kg/m
FE 5400-M-B	101.6	25.4	27	28.6	6.3	135	55	83.33	8500	5.4
FE 9400-M-B	101.6	34.9	31	38	7.9	135	55	137.25	14000	9.8
FE 12600-M-B1	152.4	38.1	36.5	45	7.9	185	80	186.27	19000	13
FE 12600-M-B2						250	100			
FE 12600-M-B3						330	125			

Note: 1) Flow conveyor chain using standard conveyor components.  
 2) Heavy duty, high wear resistance and heat resistant conveyor are available.  
 3) Flow conveyor is made to order.

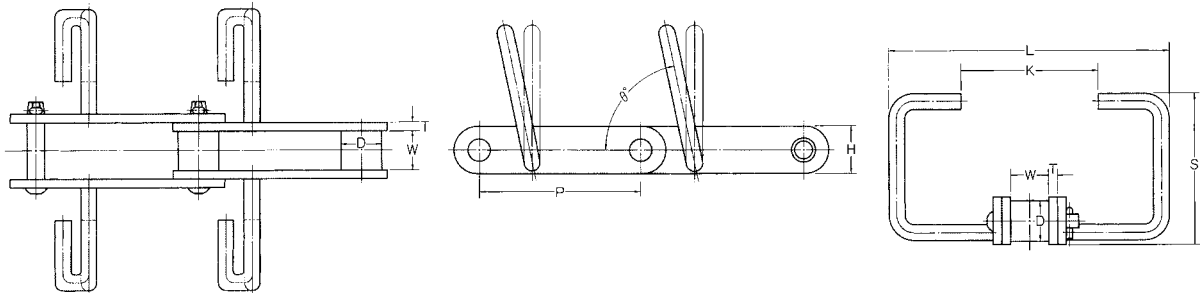

TYPE U

TYPE U

UNIT:mm

OCM Chain No.	Pitch P	Roller Diam. D	Width between L.P. W	Link Plate		Attachment				Average Breaking load		Approx weight
						Width	Height	K	θ°			
						L	S			kN	kgf	kg/m
FE 5400-M-U	101.6	25.4	27	28.6	6.3	145	110	50	90	83.33	8500	6.1
FE 9400-M-U	101.6	34.9	31	38	7.9	145	110	50	70	137.25	14000	11.1
FE 12600-M-U1	152.4	38.1	36.5	45	7.9	225	140	100	90	186.27	19000	17.1
FE 12600-M-U2						225	140	65	70			
FE 12600-M-U3						225	140	100	70			
FE 12600-M-U4						300	175	65	70			

Note: 1) Flow conveyor chain using standard conveyor components.  
 2) Heavy duty, high wear resistance and heat resistant conveyor are available.  
 3) Flow conveyor is made to order.

# FLOW CONVEYOR CHAIN

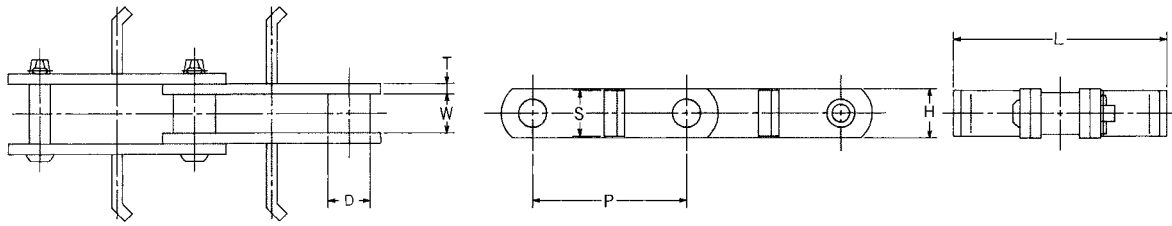

TYPE K

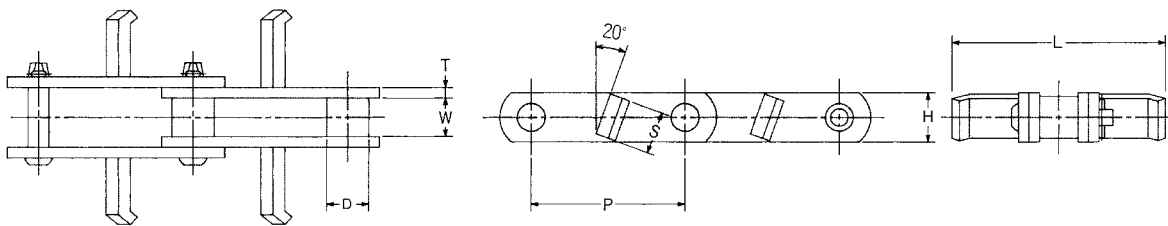

TYPE KL

TYPE K, KL

UNIT:mm

OCM Chain No.	Pitch P	Roller Diam. D	Width between L.P. W	Link Plate		Attachment		Average breaking load		Approx weight
				H	T	L	S	kN	kgf	kg/m
FE 5400-M	101.6	25.4	27	28.6	6.3	135	28	83.33	8500	6.5
FE 9400-M	101.6	34.9	31	38	7.9	185	34	137.25	14000	10.5
FE 12600-M	152.4	38.1	36.5	45	7.9	250	40	186.27	19000	12

Note: 1) Flow conveyor chain using standard conveyor chain components.  
 2) Heavy duty, high wear resistance and heat resistance conveyor are available.  
 3) Flow conveyor chain is made to order.



# DEEP LINK PLATE CONVEYOR CHAIN

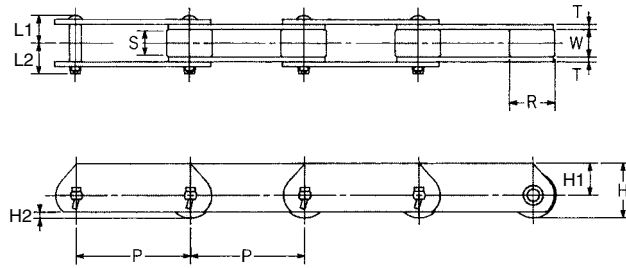

UNIT:mm

OCM Chain No.	Pitch P	R	S	Width between L.P. W	Link Plate				Pin		Weight kg/m	Allowable roller load				Average Breaking Load			
					H	H1	H2	T	L1	L2		Standard		Heavy Duty		Standard		Heavy Duty	
	P	R	S	W	H	H1	H2	T	L1	L2	kg/m	kN/pc	kg/pc	kN/pc	kg/pc	kN	kgf	kN	kgf
FMD 3075R	75										3.2								
FMD 3100R	100	30	15.5	18	36	21	4	3.2	18	20	2.8	0.59	60	0.88	90	29.41	3000	60.78	6200
FMD 5100R	100										5.9								
FMD 5150R	150	40	19	22.2	44	24	4	4.5	24	27	4.9	0.93	95	1.47	150	68.63	7000	138.24	14100
FMD10150R	150										9.7								
FMD10200R	200	50	26.5	30	57	32	6.4	6.3	32	36	8.5	1.57	160	2.6	265	112.75	11500	225.49	23000
FED12600R	152.4	57.2	31.5	36.5	63.6	35	6.1	7.9	40	46	14	2.11	215	3.53	360	186.27	19000	277.45	28000
FMD12200R	200										14.9								
FMD12250R	250	65	32	36.5	73.5	41	10	7.9	39.5	46	13.5	2.45	250	4.12	420	186.27	19000	277.45	28000
FMD17250R	250										22.5								
FMD17300R	300	80	45.8	50.8	90	50	13.8	9.5	51	59.5	21.5	4.31	440	7.16	730	245.1	25000	392.16	40000

# OUTBOARD CONVEYOR CHAIN

Base chain is FM type S roller conveyor chain with flange outboard roller. When ordering, please specify the spacing of outboard roller.

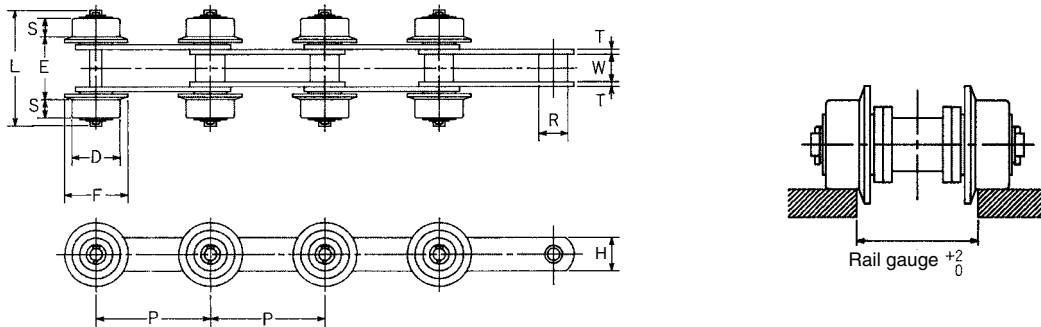

UNIT:mm

OCM Chain No.	Pitch P	R	Width between L.P. W	Link Plate		Outboard Roller			Pin		Rail gauge	*See below kg	Allowable outboard roller(both sides)			
				H	T	D	F	S	L	E			Not Heat treated		Heat treated	
	P	R	W	H	T	D	F	S	L	E	kg	kN	kgf	kN	kgf	
FM 3075-S-SR	75															
FM 3100-S-SR	100	19.05	18	22	3.2	31.8	42	12	74	38	40	0.3	0.69	70	1.08	110
FM 5075-S-SR	75															
FM 5100-S-SR	100	22.2	22.2	32	4.5	40	50	14	102	55	57	0.5	1.18	120	1.86	190
FM 5150-S-SR	150															
FM10100-S-SR	100															
FM10150-S-SR	150	30	30	38	6.3	50	65	20	135.6	73	75	1	1.86	190	3.13	320
FM12200-S-SR	200															
FM12250-S-SR	250	34.93	36.5	45	7.9	65	85	24	165	92.5	94.5	1.8	2.94	300	4.8	490
FM17200-S-SR	200															
FM17250-S-SR	250	40.1	50.8	50.8	9.5	65	85	24	186	111.4	113.4	3.8	3.04	310	5.1	520
FM17300-S-SR	300															

Note: \* Additional weight of one pair of outboard rollers.

# APRON CONVEYOR CHAIN

This OCM apron conveyor is ideal for conveying bulk material such as chips made by machine tools.

## Main features

- 1 ) Excellent for conveying small bulk material.  
Each apron plate is closely connected by hinges.  
Even tiny particle such as sand are easily conveyed.
- 2 ) Side chains are OCM standard conveyor chain.  
OCM standard sprocket can be used.
- 3 ) Specifications can be changed according to applications.
  - (1) Aprons are partitioned with plates, and different materials without mixing can be conveyed.
  - (2) For sharp inclined conveyor, stop plates are available.  
The stop plate can be installed at any desired pitch.
  - (3) For drying and freezing parts or material, small holed aprons are available.
  - (4) Stainless apron is available.

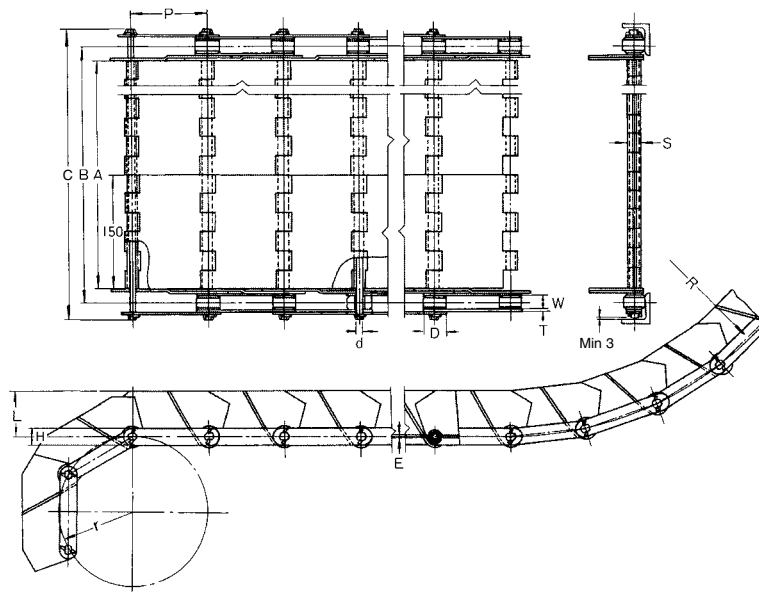
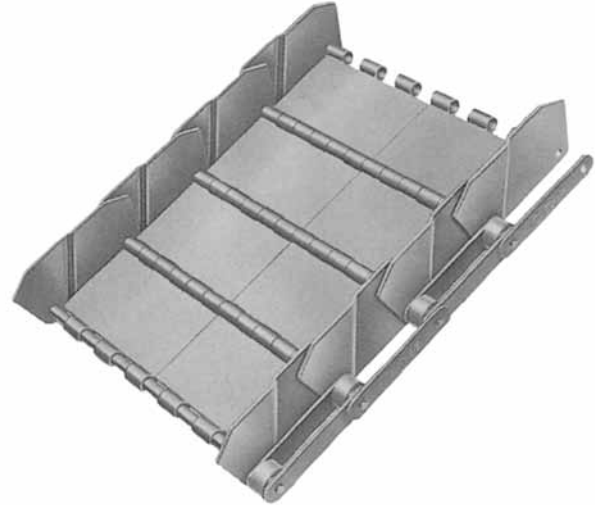

UNIT:mm

OCM Chain No.	A	B	C	L	E	S	Side Chain						Min. Upturn Radius R	Min. Downturn Radius r	Average Weight kg/m	Allowable Load (kgf)	
							OCM Chain No.	Pitch P	Roller Diam. D	Width between L.P. W	Link Plate H T	Pin Diam. d					
EC3075-150	150	188.4	227.3	40	2.0	16.4	FM3075-R	75	30	18	22	3.2	7.94	300	75	13.0	900
EC3075-300	300	338.4	377.3													17.5	
EC3075-450	450	488.4	527.3													22.4	
EC3100-150	150	188.4	227.3	60	2.0	16.4	FM3100-R	100	30	18	22	3.2	7.94	450	100	12.7	900
EC3100-300	300	338.4	377.3													16.9	
EC3100-450	450	488.4	527.3													21.1	
EC5150-150	150	200.4	252.7	80	3.2	26.0	FM5150-R	150	40	22.2	32	4.5	11.11	900	150	18.8	2000
EC5150-300	300	350.4	402.7													25.7	
EC5150-450	450	500.4	552.7													32.2	
EC5150-600	600	650.4	702.7													39.9	
EC5150-750	750	800.4	852.7													46.3	

1. When you require A dimension wider than the above, please contact us.  
Note: Dimensions subject to change. Certified dimensions furnished upon request.

# APRON CONVEYOR CHAIN

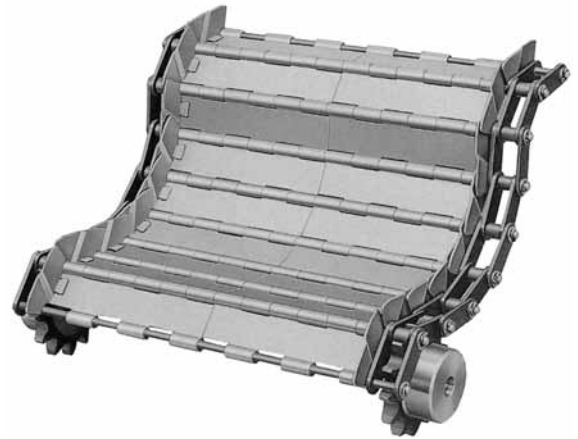
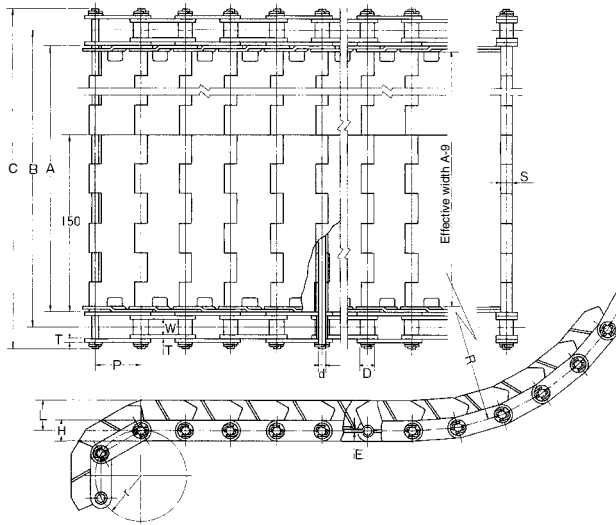

UNIT:mm

OCM Chain No.	A	B	C	L height/ thickness	Hinge thickness	S	Side Chain					Min. Upturn Radius	Min. Downturn Radius	Allowable load		Weight		
							OCM Chain No.	Pitch	Roller Diam.	Width between L.P.	Link Plate			Pin Diam.	kN		kgf	
					E			P	D	W	H	T	d	R	r			kg/m
EC2060H-150	150	176.4	214.2															8.0
EC2060H-300	300	326.4	364.2	25/2.0	2	10.4	C2060H	38.1	*11.91	12.7	17.2	3.2	5.95	200	38.1	8.82	900	13.8

Note: 1) \* 22.23 diameter is available.  
 2) A dimension wider than 150 and 300 is available.  
 3) EC2080H is also available.

# CURVE (SIDE BOW) CONVEYOR CHAIN

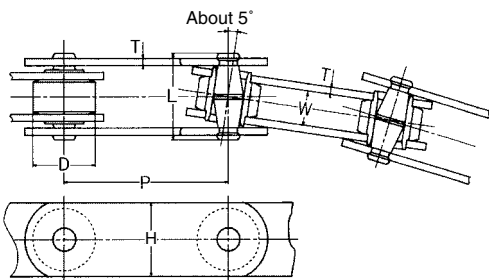

TYPE CL

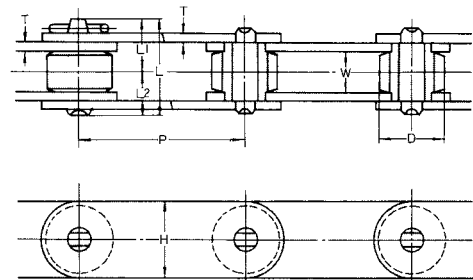

TYPE SL

UNIT:mm

OCM Chain No.	Pitch	Roller Diam.	Width between L.P.	Link Plate		Pin			Sideflex Radius		Average breaking load		Allowable load		Weight
									Min	Ordinary use	kN	kgf	kN	kgf	
	P	D	W	H	T	L	L1	L2							kg/m
CL 80	80	38	21	45	4.5	52	-	-	650	800	49.02	5000	6.68	700	5.8
CL 100	100	38	21	45	4.5	52	-	-	750	900	49.02	5000	6.68	700	6.5
SL 100	100	38	21	45	4.5	50	27	23	-	-	68.63	7000	9.80	1000	6.0